



**GROUP - 17**

## PLASTIC AND METAL WASHERS

### BOTECO Plastic and Metal Washers

A section dedicated to Boteco's plastic and metal washers. Elements with a large diameter and small thickness, ideal for use as locking system or for operating in very tight spaces. Or concave and convex washer pairs according to DIN standard.

For detailed information on the specifications of each individual product please consult the technical sheet.

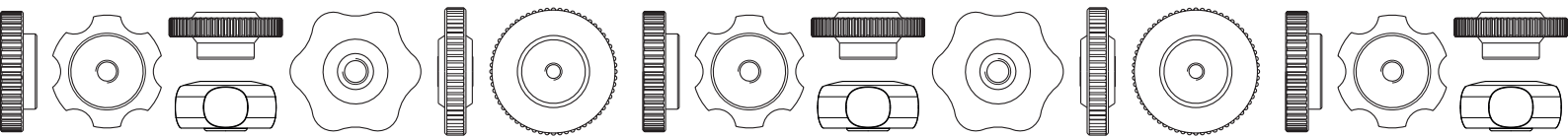

# Q260

## KNURLED WASHER



PF

UL94  
HB



### Materials:

Phenolic resin.  
Resistant to oils and greases.  
Resistant to high temperatures.

### Surface:

Glossy.

### Colour:

Black (RAL 9011).

### Inserts:

Galvanised steel insert with threaded through hole (thread tolerance 6H).

### Special Requests:

- Upon request and for special quantities inserts can be supplied in different materials.

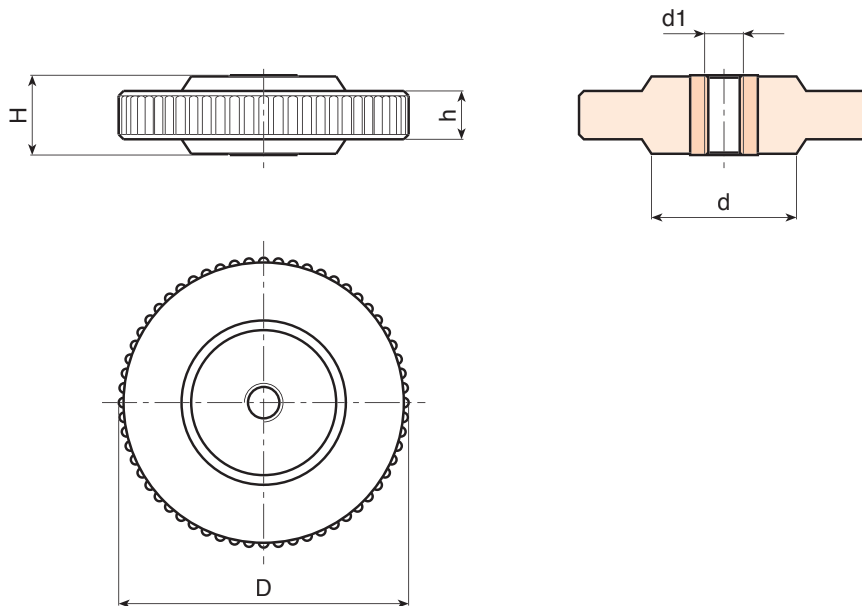

Code	art.	D	H	d	h	d1 <sub>6H</sub>	
Q26045.0001	Q26045.BM0601P	47	10	-	-	M6	31
Q26045.0003	Q26045.BM0801P	47	10	-	-	M8	32
Q26045.0005	Q26045.BM1001P	47	10	-	-	M10	34
Q26045.0006	Q26045.BM1201P	47	10	-	-	M12	35
Q26045.0007	Q26045.BM1401P	47	10	-	-	M14	38
Q26045.0008	Q26045.BM1601P	47	10	-	-	M16	42
Q26060.0001	Q26060.BM0801P	60	16	30	11	M8	62
Q26060.0002	Q26060.BM1001P	60	16	30	11	M10	65
Q26060.0003	Q26060.BM1201P	60	16	30	11	M12	68
Q26060.0005	Q26060.BM1401P	60	16	30	11	M14	70
Q26060.0006	Q26060.BM1601P	60	16	30	11	M16	73

# Q283

## 4-LOBE WASHER WITH THREADED THROUGH-HOLE INSERT



PA6  
+G.F.

UL94  
HB

RoHS  
COMPLIANT

### Materials:

Reinforced polyamide. Resistant to oils and greases.

### Surface finish:

Satin.

### Colour:

Black (RAL 9011).

### Inserts:

#### Version Q283 TM:

Brass insert with threaded through hole (thread tolerance 6H).

#### Version Q283 TQ:

Brass insert with square through bore (bore tolerance H7).

#### Version Q283 TQ-PP:

Without insert, with smooth through square hole obtained by moulding the plastic.

### Special requests:

- Upon request and for special quantities inserts can be supplied in different materials.
- Upon request and for special quantities available in the colours indicated in the chart [page 959].

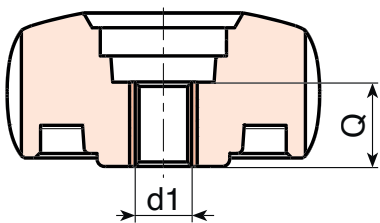
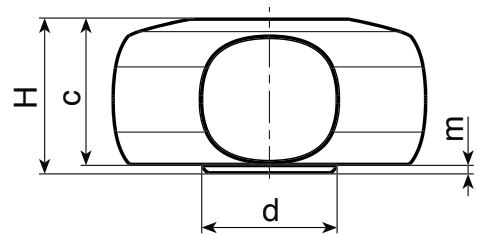
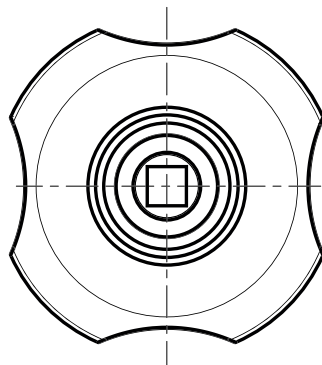
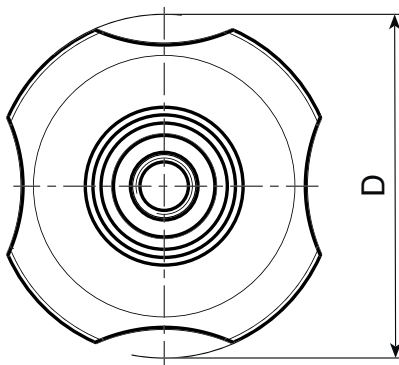

TM

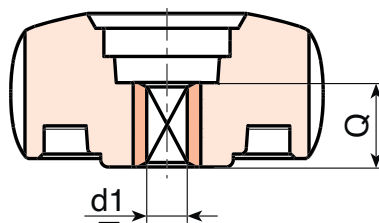

TQ

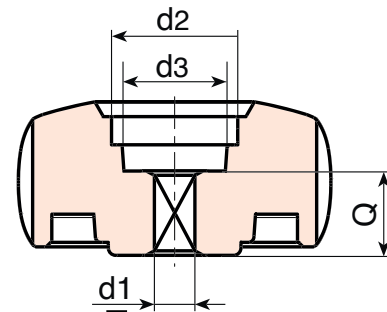

TQ-PP

# Q283

NEW



PA6  
+G.F.

UL94  
HB



## 4-LOBE WASHER WITH THREADED THROUGH-HOLE INSERT



Version Q283 TM: With brass insert and threaded through hole

Code	art.	D	H	d	d2	d3	c	m	d1 <sub>6H</sub>	Q	g
Q28340.0002	Q28340.TM0801P	40.5	20	17	18	13	19	1	M8	15	-
Q28340.0004	Q28340.TM1001P	40.5	20	17	18	13	19	1	M10	15	-
Q28350.0001	Q28350.TM0801P	49	23	20	20	15	22	1	M8	15	-
Q28360.0001	Q28360.TM1001P	59	27	23	22	18	22,5	1,5	M10	15	-
Q28360.0002	Q28360.TM1201P	59	27	23	22	18	22,5	1,5	M12	15	-
Q28380.0001	Q28380.TM1001P	79	26	30,5	22	19,5	24	2	M10	15	-
Q28380.0002	Q28380.TM1201P	79	26	30,5	22	19,5	24	2	M12	15	-

Version Q283 TQ: With brass insert and SQUARE hole

Code	art.	D	H	d	d2	d3	c	m	d1 <sub>H7</sub>	Q	g
Q28340.0005	Q28340.TQ0601P	40.5	20	17	18	13	19	1	6	15	-
Q28350.0002	Q28350.TQ0601P	49	23	20	20	15	22	1	6	15	-
Q28350.0004	Q28350.TQ0701P	49	23	20	20	15	22	1	7	15	-
Q28360.0003	Q28360.TQ0601P	59	27	23	22	18	22,5	1,5	6	15	-
Q28360.0005	Q28360.TQ0701P	59	27	23	22	18	22,5	1,5	7	15	-
Q28360.0007	Q28360.TQ0801P	59	27	23	22	18	22,5	1,5	8	15	-
Q28380.0003	Q28380.TQ0701P	79	26	30,5	22	20	24	2	7	15	-
Q28380.0005	Q28380.TQ0801P	79	26	30,5	22	20	24	2	8	15	-
Q28380.0007	Q28380.TQ0901P	79	26	30,5	22	20	24	2	9	15	-
Q28380.0009	Q28380.TQ1001P	79	26	30,5	22	20	24	2	10	15	-

Version Q283 TQ-PP: With SQUARE hole in the plastic

Code	art.	D	H	d	d2	d3	c	m	d1 <sub>+0,1</sub>	Q	g
Q28340.0006	Q28340.TQ0601PP	40.5	20	17	18	13	19	1	6	15	-
Q28350.0003	Q28350.TQ0601PP	49	23	20	20	15	22	1	6	15	-
Q28350.0005	Q28350.TQ0701PP	49	23	20	20	15	22	1	7	15	-
Q28360.0004	Q28360.TQ0601PP	59	27	23	22	18	22,5	1,5	6	15	-
Q28360.0006	Q28360.TQ0701PP	59	27	23	22	18	22,5	1,5	7	15	-
Q28360.0008	Q28360.TQ0801PP	59	27	23	22	18	22,5	1,5	8	15	-
Q28380.0004	Q28380.TQ0701PP	79	26	30,5	22	20	24	2	7	15	-
Q28380.0006	Q28380.TQ0801PP	79	26	30,5	22	20	24	2	8	15	-
Q28380.0008	Q28380.TQ0901PP	79	26	30,5	22	20	24	2	9	15	-
Q28380.0010	Q28380.TQ1001PP	79	26	30,5	22	20	24	2	10	15	-

# Q284



PA6  
+G.F.

UL94  
HB

RoHS  
COMPLIANT

## 4-LOBE WASHER WITH THROUGH-HOLE INSERT AND CENTRAL CAP

### Materials:

Reinforced polyamide. Resistant to oils and greases.

### Surface finish:

Satin.

### Colour:

Black (RAL 9011).

### Central cap:

Grey polyamide (RAL 7035). 13).

### Alternative cap colours:

Orange (RAL 2004 code 02).  
Blue (RAL 5015 code 07).  
Yellow (RAL 1021 code 10).  
Green (RAL 6024 code 17).  
Red (RAL 3000 code 16).  
Black (RAL 9011 code 01).

### Inserts:

#### Version Q284 TM:

Brass insert with threaded through hole (thread tolerance 6H).

#### Version Q284 TQ:

Brass insert with square through bore (bore tolerance H7).

#### Version Q284 TQ-PP:

Without insert, with smooth through square hole obtained by moulding the plastic.

### Special requests:

- Upon request and for special quantities inserts can be supplied in different materials.
- Upon request and for special quantities available in the colours indicated in the chart [page 959].

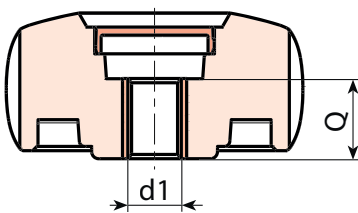
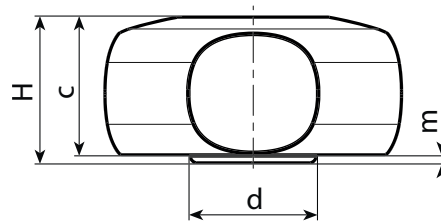
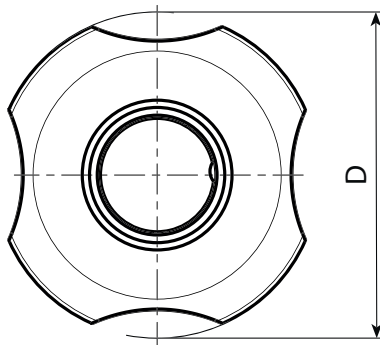

TM

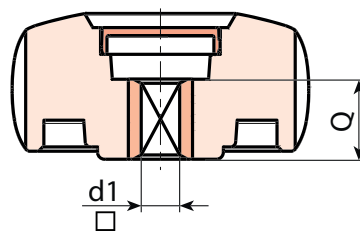

TQ

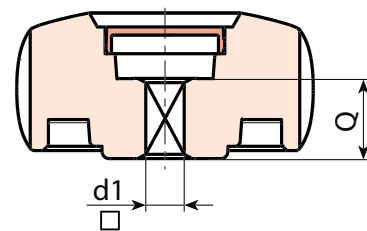

TQ-PP



# Q284



## 4-LOBE WASHER WITH THROUGH-HOLE INSERT AND CENTRAL CAP



Version Q284 TM: With brass insert and threaded through hole

Code	art.	D	H	d	d2	d3	c	m	d1 <sub>6H</sub>	Q	g
Q28440.0003	Q28440.TM0801P	40.5	20	17	18	13	19	1	M8	15	-
Q28440.0004	Q28440.TM1001P	40.5	20	17	18	13	19	1	M10	15	-
Q28450.0001	Q28450.TM0801P	49	23	20	20	15	22	1	M8	15	-
Q28460.0001	Q28460.TM1001P	59	27	23	22	18	22,5	1,5	M10	15	-
Q28460.0002	Q28460.TM1201P	59	27	23	22	18	22,5	1,5	M12	15	-
Q28480.0001	Q28480.TM1001P	79	26	30,5	22	20	24	2	M10	15	-
Q28480.0002	Q28480.TM1201P	79	26	30,5	22	20	24	2	M12	15	-

Version Q284 TQ: With brass insert and SQUARE hole

Code	art.	D	H	d	d2	d3	c	m	d1 <sub>H7</sub>	Q	g
Q28440.0005	Q28440.TQ0601P	40.5	20	17	18	13	19	1	6	15	-
Q28450.0002	Q28450.TQ0601P	49	23	20	20	15	22	1	6	15	-
Q28450.0004	Q28450.TQ0701P	49	23	20	20	15	22	1	7	15	-
Q28460.0003	Q28460.TQ0601P	59	27	23	22	18	22,5	1,5	6	15	-
Q28460.0005	Q28460.TQ0701P	59	27	23	22	18	22,5	1,5	7	15	-
Q28460.0007	Q28460.TQ0801P	59	27	23	22	18	22,5	1,5	8	15	-
Q28480.0003	Q28480.TQ0701P	79	26	30,5	22	20	24	2	7	15	-
Q28480.0005	Q28480.TQ0801P	79	26	30,5	22	20	24	2	8	15	-
Q28480.0007	Q28480.TQ0901P	79	26	30,5	22	20	24	2	9	15	-
Q28480.0009	Q28480.TQ1001P	79	26	30,5	22	20	24	2	10	15	-

Version Q284 TQ-PP: With SQUARE hole in the plastic

Code	art.	D	H	d	d2	d3	c	m	d1 <sub>+0,1</sub>	Q	g
Q28440.0006	Q28440.TQ0601PP	40.5	20	17	18	13	19	1	6	15	-
Q28450.0003	Q28450.TQ0601PP	49	23	20	20	15	22	1	6	15	-
Q28450.0005	Q28450.TQ0701PP	49	23	20	20	15	22	1	7	15	-
Q28460.0004	Q28460.TQ0601PP	59	27	23	22	18	22,5	1,5	6	15	-
Q28460.0006	Q28460.TQ0701PP	59	27	23	22	18	22,5	1,5	7	15	-
Q28460.0008	Q28460.TQ0801PP	59	27	23	22	18	22,5	1,5	8	15	-
Q28480.0004	Q28480.TQ0701PP	79	26	30,5	22	20	24	2	7	15	-
Q28480.0006	Q28480.TQ0801PP	79	26	30,5	22	20	24	2	8	15	-
Q28480.0008	Q28480.TQ0901PP	79	26	30,5	22	20	24	2	9	15	-
Q28480.0010	Q28480.TQ1001PP	79	26	30,5	22	20	24	2	10	15	-

# Q261

## LOBED WASHER

+135°  
-30°

PA6  
+G.F.

UL94  
HB

RoHS  
COMPLIANT

### Materials:

Reinforced polyamide.  
Resistant to oils and greases.

### Surface:

Satin.

### Colour:

Black (RAL 9011).

### Inserts:

Galvanised steel insert with threaded through hole (thread tolerance 6H).

### Special Requests:

- Upon request and for special quantities inserts can be supplied in different materials.
- Upon request and for special quantities available in the colours indicated in the chart [page 959].

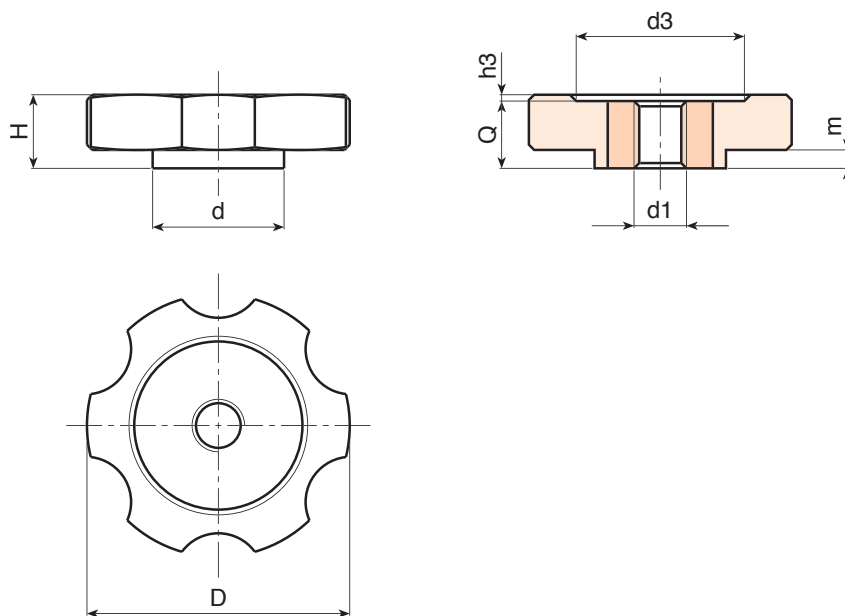

Code	art.	D	H	d	m	h3	d3	d1 <sub>6H</sub>	Q	g
Q26140.0003	Q26140.TM0801P	40	12	25	2	1.5	22	M8	11	21
Q26140.0005	Q26140.TM1001P	40	12	25	2	1.5	22	M10	11	22
Q26140.0007	Q26140.TM1201P	40	12	25	2	1.5	22	M12	11	24
Q26150.0001	Q26150.TM0801P	50	14	25	3.5	1.5	32	M8	13	31
Q26150.0002	Q26150.TM1001P	50	14	25	3.5	1.5	32	M10	13	32
Q26150.0003	Q26150.TM1201P	50	14	25	3.5	1.5	32	M12	13	35



# Q262

## KNURLED WASHER



**Materials:**

Reinforced polyamide.  
Resistant to oils and greases.

**Surface:**

Satin.

**Colour:**

Black (RAL 9011).

**Hole:**

Threaded through hole obtained by moulding the plastic (tolerance not applicable).

**Special Requests:**

- Upon request and for special quantities hole d1 can be supplied to customer's drawing.

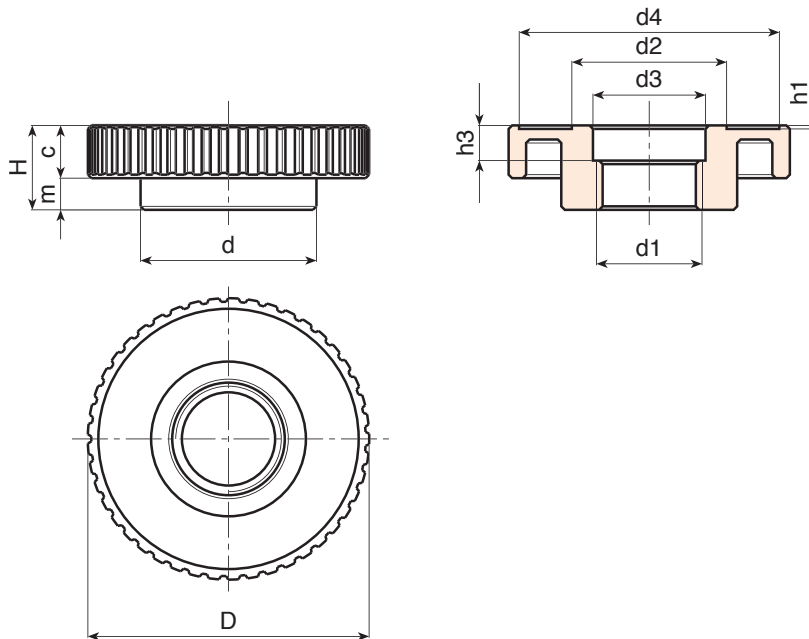

Code	art.	D	H	d	c	m	h1	h3	d2	d3	d4	d1	
Q26280.0002	Q26280.TB3001P	81	24	50	14.5	9.5	1	10	43.5	32	74	M30x1,5	65



# Q263

## KNURLED WASHER

+135°  
-30°

PA6  
+G.F.

UL94  
HB

RoHS  
COMPLIANT

### Materials:

Reinforced polyamide.  
Resistant to oils and greases.

### Surface:

Satin.

### Colour:

Black (RAL 9011).

### Hole:

Threaded through hole obtained by moulding the plastic  
(tolerance not applicable).

### Special Requests:

- Upon request and for special quantities hole d1 can be supplied to customer's drawing.

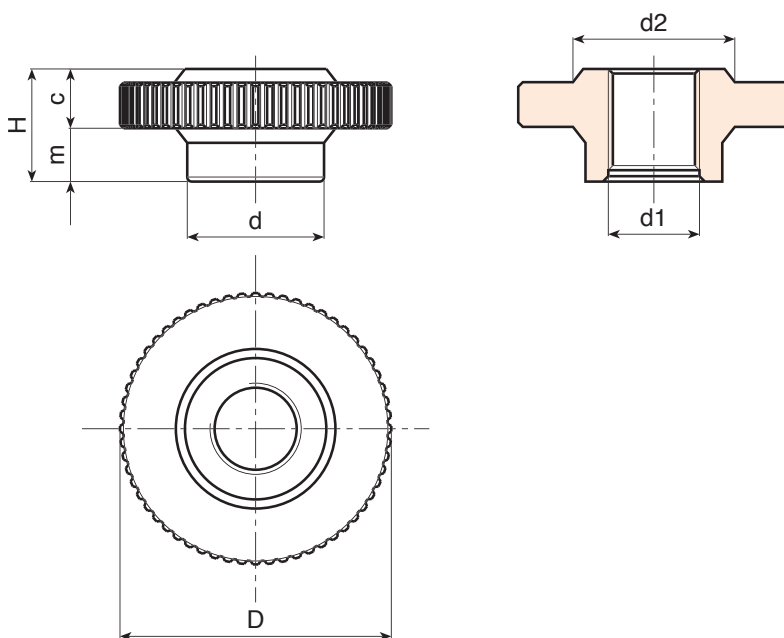

Code	art.	D	H	d	c	m	d2	d1	g
Q26360.0002	Q26360.TM2001P	60	25	30	12	13	35	M20	38
Q26360.0003	Q26360.TM2401P	60	25	30	12	13	35	M24	35

# Q264

## 6-LOBE WASHER



**Materials:**

Reinforced polyamide.  
Resistant to oils and greases.

**Surface:**

Satin.

**Colour:**

Black (RAL 9011).

**Inserts:**

Brass insert with threaded through hole (thread tolerance 6H).

**Special Requests:**

- Upon request and for special quantities inserts can be supplied in different materials.
- Upon request and for special quantities available in the colours indicated in the chart [page 959].

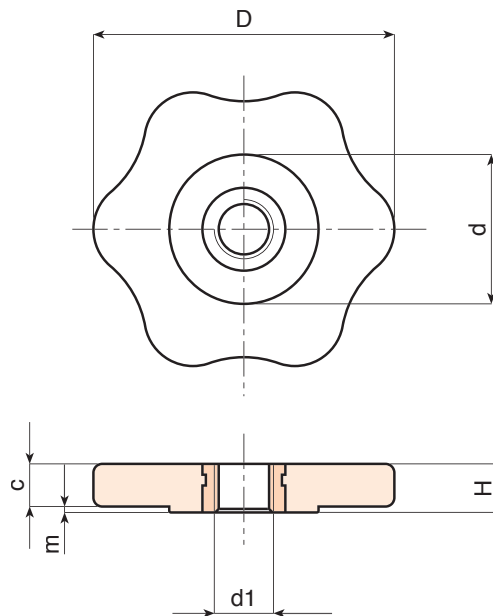

Code	art.	D	H	d	c	m	d1 <sub>6H</sub>	
Q26450.0002	Q26450.TM0601P	50	8	25	7	1	M6	18
Q26450.0003	Q26450.TM0801P	50	8	25	7	1	M8	18
Q26450.0005	Q26450.TM1001P	50	8	25	7	1	M10	20

# W184

## STEEL WASHER WITH SMOOTH BORE



AVP

Aisi  
303



### Materials:

#### W184:

Steel with strength class 3.8.

#### W184PIN:

Stainless steel (Aisi 303).

### Surface finish:

Turned with low roughness.

### Colour:

#### W184:

Standard blue zinc plating (galvanic treatment).

#### W184 PIN:

Natural.

### Hole:

Smooth through bore machined from solid metal (hole tolerance H10).

### Special requests:

- None.

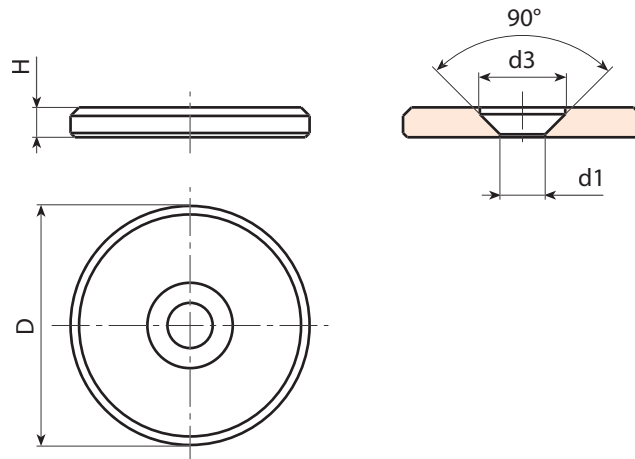

### Version W184 - nickel-plated steel

Code	Art.	d	D	H	d1 <sub>H10</sub>	
-	W18416.VP4,5Z	16	3	8	4,5 x M4	4.5
-	W18420.VP4,5Z	20	3	8	4,5 x M4	7
-	W18422.VP5,5Z	22	3.5	10	5,5 x M5	10
-	W18425.VP5,5Z	25	3.5	10	5,5 x M5	13
-	W18428.VP5,5Z	28	3.5	10	5,5 x M5	16
-	W18432.VP6,5Z	32	4	12	6,5 x M6	24
-	W18436.VP6,5Z	36	4	12	6,5 x M6	31
-	W18440.VP6,5Z	40	5	12	6,5 x M6	48

### Version W184 PIN - stainless steel (Aisi 303)

INOX

Code	Art.	d	D	H	d1 <sub>H10</sub>	
-	W18416.IP4,5PIN	16	3	8	4,5 x M4	4.5
-	W18420.IP4,5PIN	20	3	8	4,5 x M4	7
-	W18422.IP5,5PIN	22	3.5	10	5,5 x M5	10
-	W18425.IP5,5PIN	25	3.5	10	5,5 x M5	13
-	W18428.IP5,5PIN	28	3.5	10	5,5 x M5	16
-	W18432.IP6,5PIN	32	4	12	6,5 x M6	24
-	W18436.IP6,5PIN	36	4	12	6,5 x M6	31
-	W18440.IP6,5PIN	40	5	12	6,5 x M6	48

# Y637

## DIN 6372 - C-WASHER



### Materials:

Quenched and tempered steel.

### Surface finish:

Heat-treated.

### Colour:

Black-oxide treatment.

### Special requests:

- None.

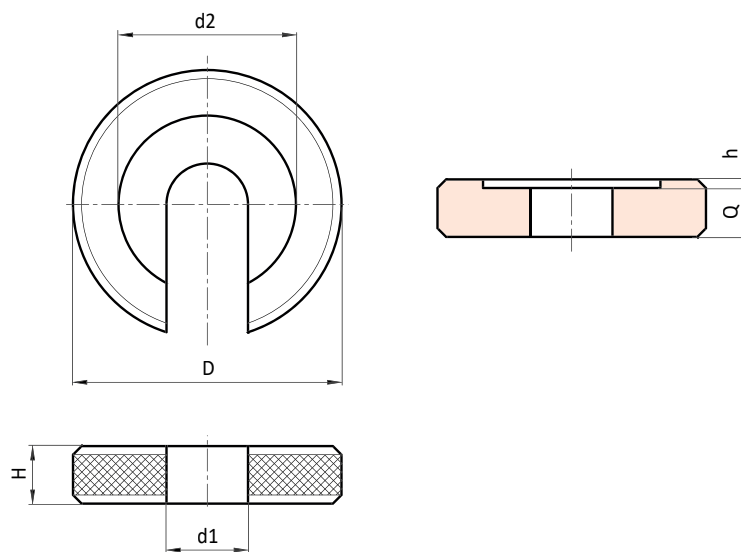

Code	Art.	D	H	h	d2	d1	Q	g
Y637017.0001	Y637017.SD05.25	17	5	0.75	12	5.25	4.25	6
Y637022.0001	Y637022.SD06.4	22	6	0.8	16	6.4	5.2	12
Y637028.0001	Y637028.SD08.4	28	7	1	21	8.4	6	23
Y637034.0001	Y637034.SD10.5	34	8	1.2	25	10.5	6.8	38
Y637040.0001	Y637040.SD13	40	9	1.8	30	13	7.2	57
Y637048.0001	Y637048.SD14.5	48	12	1.8	33	14.5	10.2	117
Y637056.0001	Y637056.SD17	56	12	1.8	37	17	10.2	146
Y637064.0001	Y637064.SD21	64	14	2	45	21	12	234
Y637075.0001	Y637075.SD25	75	16	2	52	25	14	374
Y637090.0001	Y637090.SD31	90	18	2	65	31	16	720
Y637100.0001	Y637100.SD37	100	20	2.5	75	37	17.5	791

# Y319



## DIN 6319 ed. 10/01 - STEEL CONVEX C DESIGN WASHER

### Materials:

**Y319:**  
Case-hardened steel.

**Y319PIN:**  
Stainless steel (Aisi 303).

### Surface finish:

**Y319:**  
Smooth, case-hardened.

**Y319PIN:**  
Natural, untreated.

### Colour:

**Y319:**  
Standard black-oxide treatment.

**Y319PIN:**  
Natural.

### Special requests:

- None.

### Notes:

Attention: convex washer Y319 must be used with concave washer Y320 or Y321 (to be ordered separately).

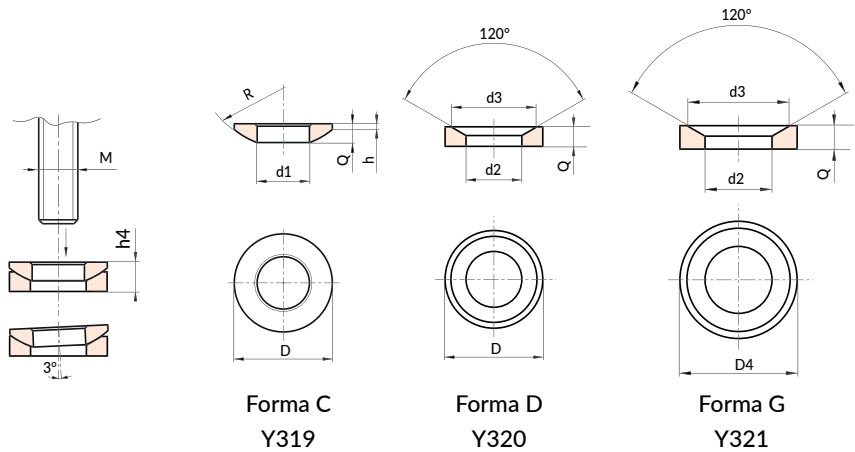

Forma C  
Y319

Forma D  
Y320

Forma G  
Y321

### Version DIN 6319 C Design - black-oxide treated steel convex washer

Code	Art.	D	R	h	d1 <sub>H13</sub>	M	Q	Max. permissible static load	kN	
Y319010.0001	Y319010.SD05.25	10.5	7.5	0.4	5.25	M05	2	-	0.7	
Y319012.0002	Y319012.SD06.4	12	9	0.7	6.4	M06	2.3	9	1	
Y319017.0002	Y319017.SD08.4	17	12	0.6	8.4	M08	3.2	17	2.8	
Y319021.0002	Y319021.SD10.5	21	15	0.8	10.5	M10	4	26	5	
Y319024.0002	Y319024.SD13	24	17	1.1	13	M12	4.6	38	8	
Y319028.0001	Y319028.SD15	28	22	1.2	15	M14	5	53	11	
Y319030.0002	Y319030.SD17	30	22	1.3	17	M16	5.3	73	13	
Y319036.0002	Y319036.SD21	36	27	2	21	M20	6.3	117	23	
Y319044.0002	Y319044.SD25	44	32	2.4	25	M24	8.2	168	21	
Y319056.0002	Y319056.SD31	56	41	3.6	31	M30	11.2	269	103	
Y319068.0002	Y319068.SD37	68	50	4.6	37	M36	14	394	188	
Y319078.0002	Y319078.SD43	78	58	6.5	43	M42	17	542	316	
Y319092.0002	Y319092.SD50	92	67	8	50	M48	21	714	549	
Y319103.0001	Y319103.SD58	103	79	9.5	58	M56	23	-	748	
Y319120.0001	Y319120.SD66	120	93	12	66	M64	27	-	1239	



### Version DIN 6319 C Design - stainless steel (Aisi 303) convex washer

Code	Art.	D	R	h	d1 <sub>H13</sub>	M	Q	Max. permissible static load	kN	
Y319012.0001	Y319012.ID06.4PIN	12	9	0.7	6.4	M06	2.3	6	1	
Y319017.0001	Y319017.ID08.4PIN	17	12	0.6	8.4	M08	3.2	12	2.8	
Y319021.0001	Y319021.ID10.5PIN	21	15	0.8	10.5	M10	4	16	5	
Y319024.0001	Y319024.ID13PIN	24	17	1.1	13	M12	4.6	24	7	
Y319030.0001	Y319030.ID17PIN	30	22	1.3	17	M16	5.3	45	13	
Y319036.0001	Y319036.ID21PIN	36	27	2	21	M20	6.3	71	24	
Y319044.0001	Y319044.ID25PIN	44	32	2.4	25	M24	8.2	105	44	
Y319056.0001	Y319056.ID31PIN	56	41	3.6	31	M30	11.2	191	106	
Y319068.0001	Y319068.ID37PIN	68	50	4.6	37	M36	14	-	194	
Y319078.0001	Y319078.ID43PIN	78	58	6.5	43	M42	17	-	311	
Y319092.0001	Y319092.ID50PIN	92	67	8	50	M48	21	-	550	



# Y320



## DIN 6319 ed. 10/01 - CONCAVE D DESIGN WASHER

### Materials:

**Y320:**

Case-hardened steel.

**Y320PIN:**

Stainless steel (Aisi 303).

### Surface finish:

**Y320:**

Smooth, case-hardened.

**Y320PIN:**

Natural, untreated.

### Colour:

**Y320:**

Standard black-oxide treatment.

**Y320PIN:**

Natural.

### Special requests:

- None.

### Notes:

Attention: concave washer Y320 must be used with convex washer Y319 (to be ordered separately).

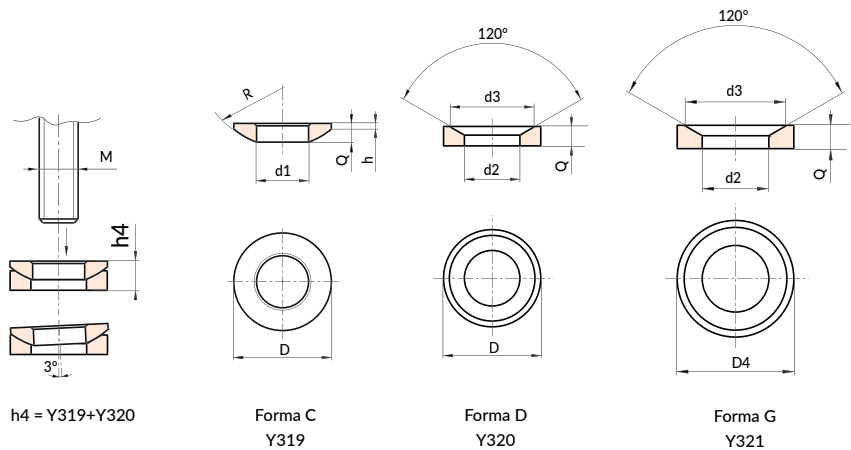

### Version DIN 6319 D Design - black-oxide treated steel concave washer

Code	Art.	D	d3	h4 (Y319+Y320)	d2H13	M	Q	Max. permissible static load kN	
Y320010.0001	Y320010.SD06	10.5	9.25	3.1	6	M05	2.1	-	0.8
Y320012.0002	Y320012.SD07.1	12	11	4	7.1	M06	2.8	9	1.4
Y320017.0002	Y320017.SD09.6	17	14.5	5.6	9.6	M08	3.5	17	3.6
Y320021.0002	Y320021.SD12	21	18.5	6.3	12	M10	4.2	26	6.5
Y320024.0002	Y320024.SD14.2	24	20	8	14.2	M12	5	38	10
Y320028.0001	Y320028.SD16.5	28	24.8	8.2	16.5	M14	5.6	53	15
Y320030.0002	Y320030.SD19	30	26	9.3	19	M16	6.2	73	18
Y320036.0002	Y320036.SD23.2	36	31	11.6	23.2	M20	7.5	117	30
Y320044.0002	Y320044.SD28	44	37	15	28	M24	9.5	168	61
Y320056.0002	Y320056.SD35	56	49	18.9	35	M30	12	269	124
Y320068.0002	Y320068.SD42	68	60	23.3	42	M36	15	394	232
Y320078.0002	Y320078.SD49	78	70	28.3	49	M42	18	542	360
Y320092.0002	Y320092.SD56	92	82	35.2	56	M48	22	714	633
Y320103.0001	Y320103.SD65	103	92	39.7	65	M56	25	-	873
Y320120.0001	Y320120.SD75	120	110	46.5	75	M64	30	-	1422

### Version DIN 6319 D Design - stainless steel (Aisi 303) concave washer



Code	Art.	D	d3	h4 (Y319+Y320)	d2H13	M	Q	Max. permissible static load kN	
-	Y320012.SD07.1PIN	12	11	4	7.1	M06	2.8	6	1.4
Y320017.0001	Y320017.ID09.6PIN	17	14.5	5.6	9.6	M08	3.5	12	3.6
Y320021.0001	Y320021.ID12PIN	21	18.5	6.3	12	M10	4.2	16	6.5
Y320024.0001	Y320024.ID14.2PIN	24	20	8	14.2	M12	5	24	10
Y320030.0001	Y320030.ID19PIN	30	26	9.3	19	M16	6.2	45	18
Y320036.0001	Y320036.ID23.2PIN	36	31	11.6	23.2	M20	7.5	71	30
Y320044.0001	Y320044.ID28PIN	44	37	15	28	M24	9.5	105	61
Y320056.0001	Y320056.ID35PIN	56	49	18.9	35	M30	12	191	124
Y320068.0001	Y320068.ID42PIN	68	60	23.3	42	M36	15	-	232
Y320078.0001	Y320078.ID49PIN	78	70	28.3	49	M42	18	-	360
Y320092.0001	Y320092.ID56PIN	92	82	35.2	56	M48	22	-	633

# Y321



## DIN 6319 ed. 10/01 - STAINLESS STEEL CONCAVE G DESIGN WASHER

### Materials:

#### Y321:

Quenched and tempered steel.

#### Y321PIN:

Stainless steel (Aisi 303).

### Surface finish:

#### Y321:

Heat treated HV 390± 40.

#### Y321PIN:

Natural, untreated.

### Colour:

#### Y321:

Standard black-oxide treatment.

#### Y321PIN:

Natural.

### Special requests:

- None.

### Notes:

Attention: concave washer Y321 must be used with convex washer Y319 (to be ordered separately).

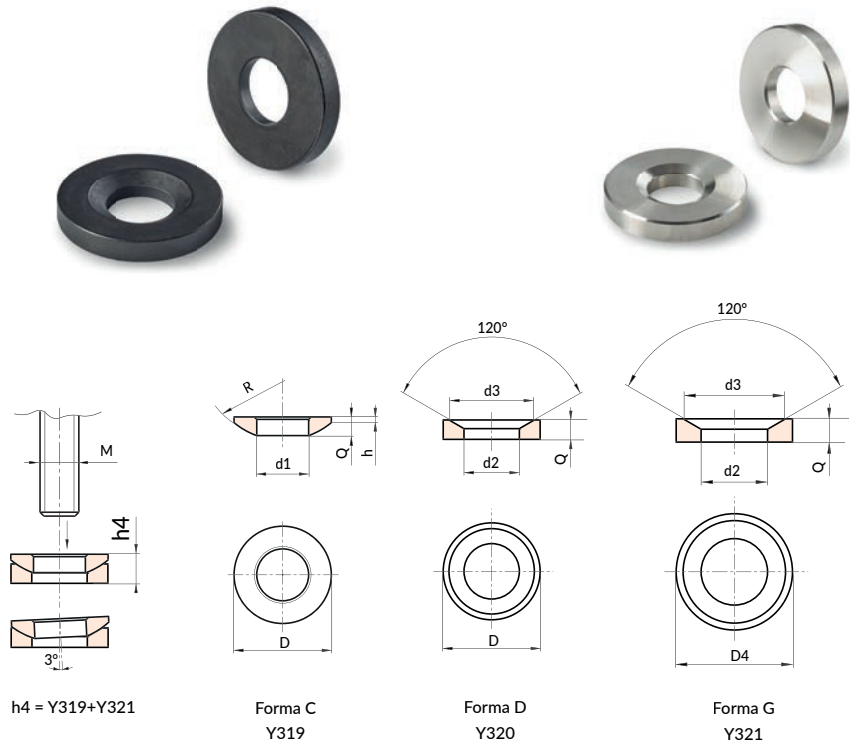

h4 = Y319+Y321

Forma C  
Y319

Forma D  
Y320

Forma G  
Y321

### Version DIN 6319 G Design - black-oxide treated steel concave washer

Code	Art.	D	d3	h4 (Y319+Y321)	d2H13	M	Q	Max. permissible static load kN	
Y321015.0001	Y321015.SD06	15	9.25	3.5	6	M05	2.5	-	3.6
Y321017.0002	Y321017.SD07.1	17	11	5.2	7.1	M06	4	9	3.6
Y321024.0002	Y321024.SD09.6	24	14.5	6.8	9.6	M08	5	17	10
Y321030.0002	Y321030.SD12	30	18.5	7.1	12	M10	5	26	18
Y321036.0002	Y321036.SD14.2	36	20	9	14.2	M12	6	38	30
Y321040.0001	Y321040.SD16.5	40	24.8	8.6	16.5	M14	6	53	38
Y321044.0002	Y321044.SD19	44	26	10.1	19	M16	7	73	61
Y321050.0002	Y321050.SD23.2	50	31	12	23.2	M20	8	117	124
Y321060.0002	Y321060.SD28	60	37	15.5	28	M24	10	168	232
Y321068.0002	Y321068.SD35	68	49	18.7	35	M30	12	269	360
Y321080.0001	Y321080.SD42	80	60	20.3	42	M36	12	394	633

### Version DIN 6319 G Design - stainless steel (Aisi 303) concave washer



Code	Art.	D	d3	h4 (Y319+Y321)	d2H13	M	Q	Max. permissible static load kN	
-	Y321017.SD07.1PIN	17	11	5.2	7.1	M06	4	6	3.6
Y321024.0001	Y321024.ID09.6PIN	24	14.5	6.8	9.6	M08	5	12	10
Y321030.0001	Y321030.ID12PIN	30	18.5	7.1	12	M10	5	16	18
Y321036.0001	Y321036.ID14.2PIN	36	20	9	14.2	M12	6	24	30
Y321044.0001	Y321044.ID19PIN	44	26	10.1	19	M16	7	45	61
Y321050.0001	Y321050.ID23.2PIN	50	31	12	23.2	M20	8	71	124
Y321060.0001	Y321060.ID28PIN	60	37	15.5	28	M24	10	105	232
Y321068.0001	Y321068.ID35PIN	68	49	18.7	35	M30	12	191	360