



GROUP - 14

PLASTIC AND METAL CONTROL KNOBS

BOTECA Plastic and Metal Control Knobs

Group of products for moving and adjusting the control axis of various types of machinery: from woodworking machines to packaging machines. Plastic and metal products, often with knurling designed to provide good grip for bare hands or gloves. Some models are designed for the addition of a graduated scale and flange customized to meet the needs of individual customers. For these products as well we can offer a customization service for the keying hole, pad printing and coloured caps. For detailed information on the specifications of each individual product please consult the technical sheet.

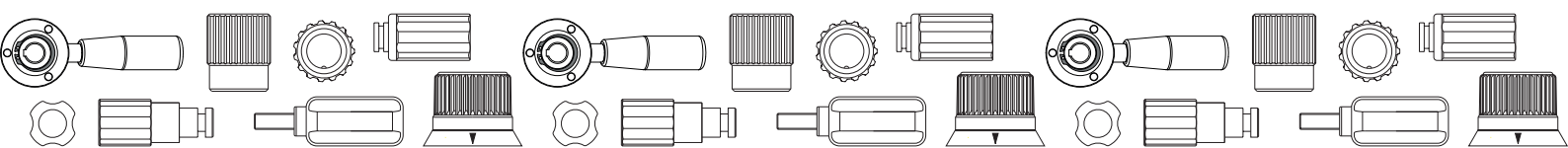

N240



CONTROL KNOB WITH METAL INSERT AND THROUGH HOLE

Materials:

Reinforced polyamide.
Resistant to oils and greases.

Surface finish:

Satin.

Colour:

Black (RAL 9011).

Inserts:

Galvanised steel insert with threaded through hole and empty body top (6H thread tolerance).

Special requests:

- None.

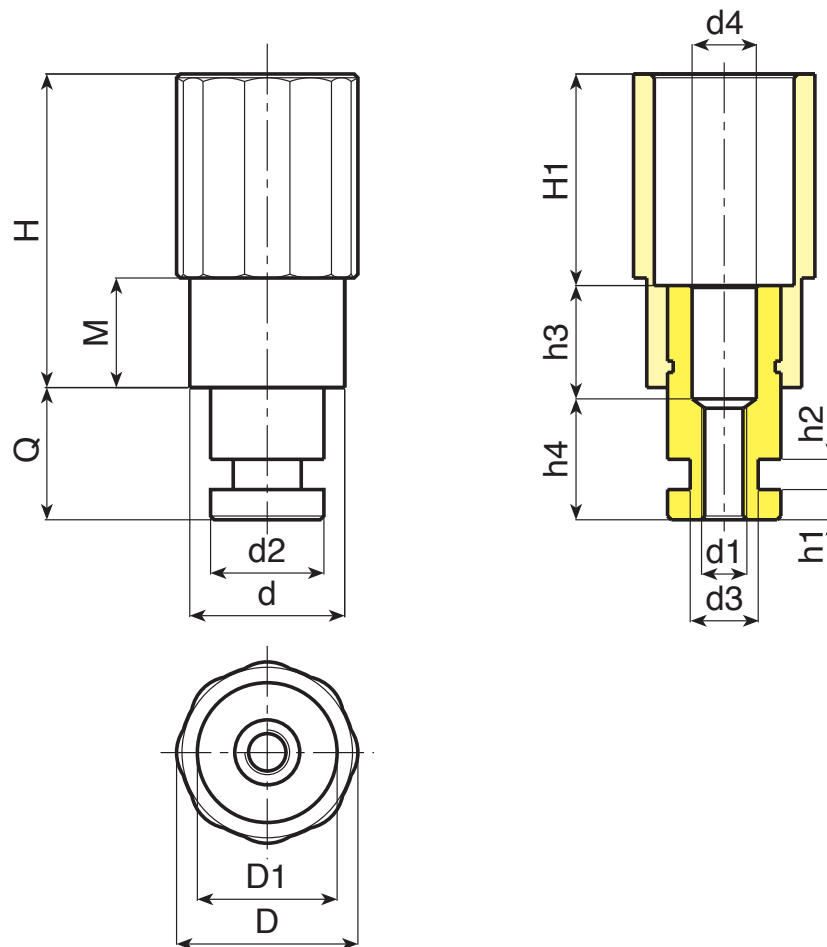

Code	Art.	D	D1	d	H	H1	M	Q	d2	d1	d3	d4	h1	h2	h3	h4		
-	N24040.T.....01	39	21	32	63	33	12	25÷40	20	A.R.	A.R.	A.R.	A.R.	A.R.	A.R.	A.R.	A.R.	-
-	N24050.T.....01	48	36	41	83	55	29	25÷40	28÷30	A.R.	A.R.	A.R.	A.R.	A.R.	A.R.	A.R.	A.R.	-

A.R. = Only upon customer's request. Minimum of 200 pieces.



N244

CONTROL KNOB WITH METAL INSERT AND THROUGH HOLE



Materials:

Reinforced polyamide.
Resistant to oils and greases.

Surface finish:

Satin.

Colour:

Black (RAL 9011).

Inserts:

Galvanised steel insert with threaded through hole and empty body top (6H thread tolerance).

Special requests:

- None.

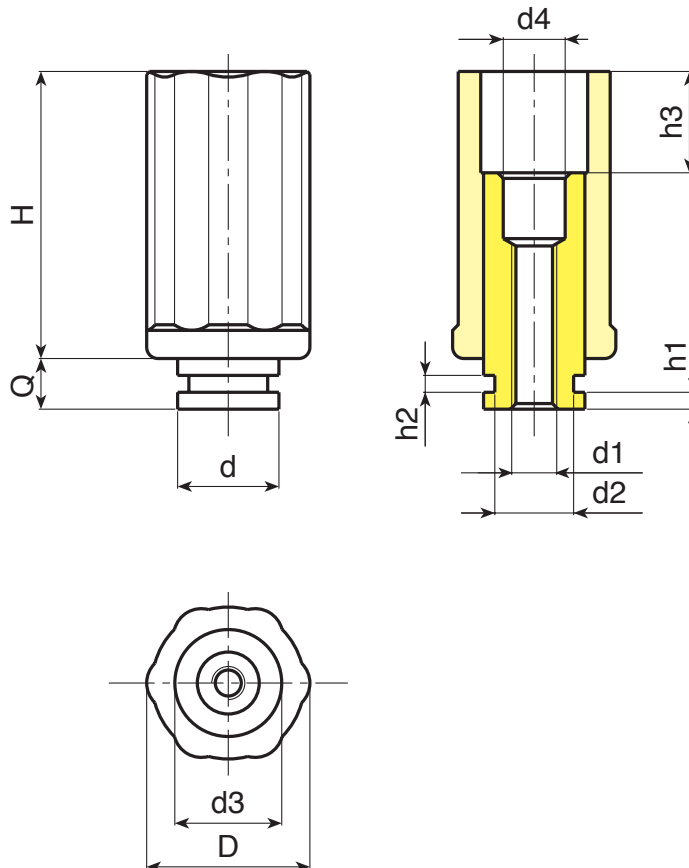

Code	Art.	D	H	d3	h3	Q	d	d1	d2	d4	h1	h2	
-	N24430.T.....	30	21	32	63	33	12	25÷40	20	A.R.	A.R.	A.R.	-
-	N24450.T.....	50	36	41	83	55	29	25÷40	28÷30	A.R.	A.R.	A.R.	-

A.R. = Only upon customer's request. Minimum of 200 pieces.



N241



CONTROL KNOB WITH CAP AND THREADED HOLE INSERT

Materials:

Reinforced polyamide.
Resistant to oils and greases.

Surface finish:

Satin.

Colour:

Black (RAL 9011).

Cap:

Central cap in grey polyamide (RAL 7035).

Alternative cap colours:

Orange (RAL 2004 code 02).
Blue (RAL 5015 code 07).
Yellow (RAL 1021 code 10).
Red (RAL 3000 code 16).
Green (RAL 6024 code 17).
Black (RAL 9011 code 01).

Inserts:

Brass insert with female threaded hole (thread tolerance 6H).
(* Galvanised steel insert with female threaded hole (thread tolerance 6H).

Special requests:

- Upon request and for special quantities inserts can be supplied in different materials.
- Upon request and for special quantities available in the colours indicated in the chart (attention: reduced range) [page 959].

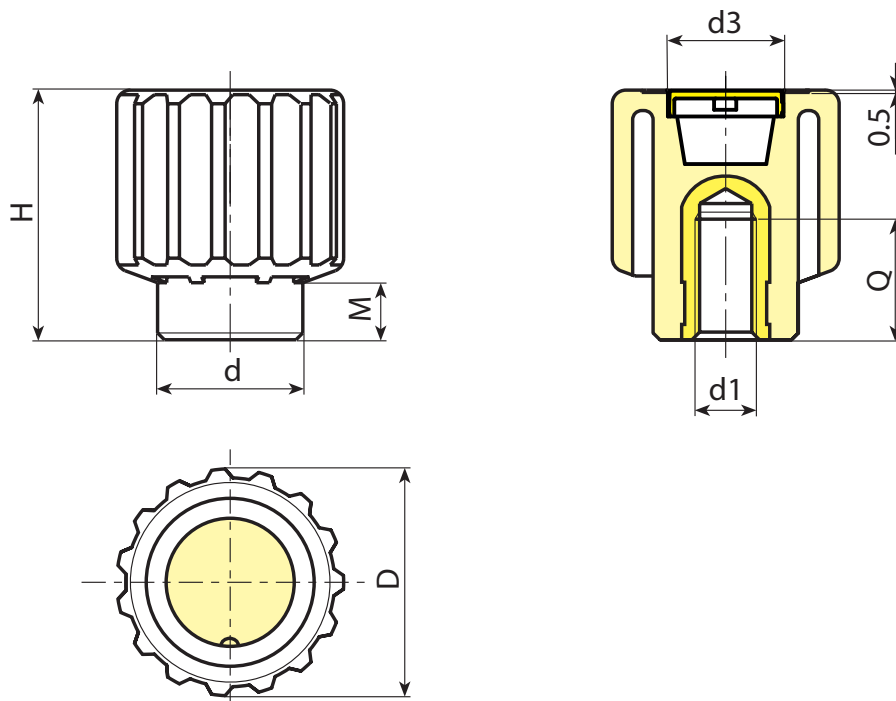

Code	Art.	D	H	M	d	d3	d1 _{6H}	Q	g
N24150.0009	N24150.TM0801	50	55	13	32	34	M8	13	92
N24150.0010	N24150.TM1001	50	55	13	32	34	M10	13	92
N24150.0013	N24150.TM1201	50	55	13	32	34	M12	17	83
N24150.0015	N24150.TM1401	50	55	13	32	34	M14	17	82
N24150.0017	N24150.TM1601	50	55	13	32	34	M16 (*)	16	96

N740

KNURLED CONTROL KNOB WITH THREADED HOLE INSERT



Materials:

Reinforced polyamide.
Resistant to oils and greases.

Surface finish:

Satin.

Colour:

Black (RAL 9011).

Inserts:

Brass insert with female threaded hole (thread tolerance 6H).

Special requests:

- Upon request and for special quantities inserts can be supplied in different materials.
- Upon request and for special quantities available in the colours indicated in the chart (attention: reduced range) [page 959].

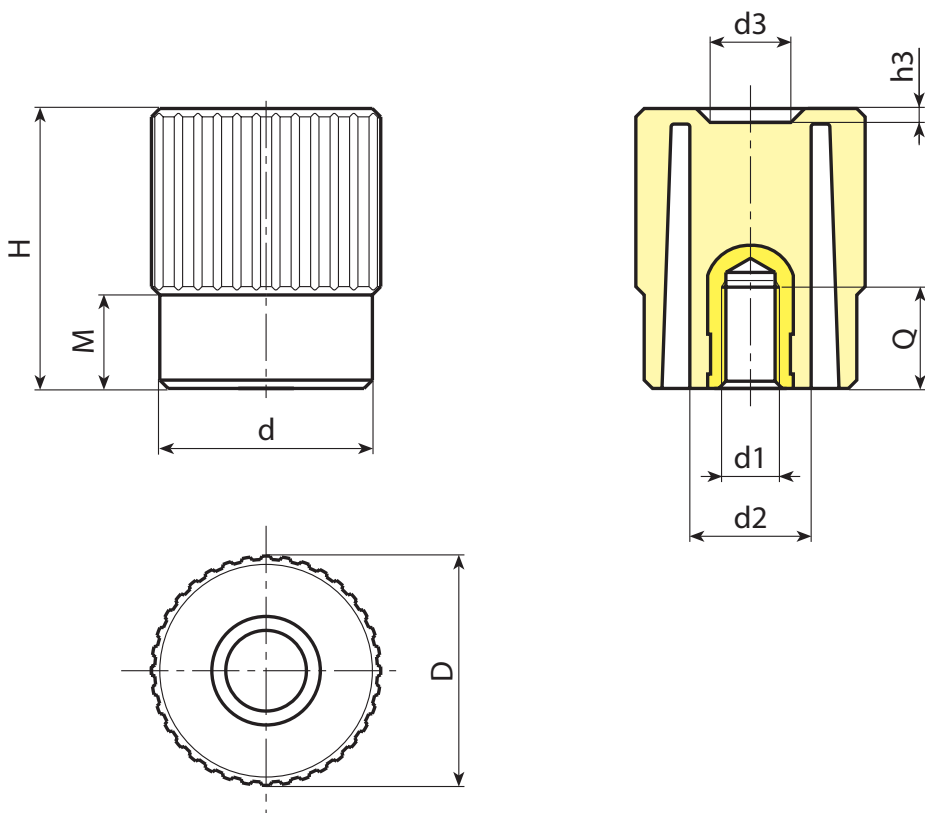

Code	Art.	D	H	M	d	d2	d3	h3	d1 _{6H}	Q	
N74040.0002	N74040.TM0801	42	50,5	17	38	22	15,5	2,5	M8	18	65
N74040.0003	N74040.TM1001	42	50,5	17	38	22	15,5	2,5	M10	22	66
N74040.0005	N74040.TM1201	42	50,5	17	38	22	15,5	2,5	M12	17	68
N74040.0006	N74040.TM1401	42	50,5	17	38	22	15,5	2,5	M14	17	69

N741

KNURLED CONTROL KNOB WITH THREADED STUD



Materials:

Reinforced polyamide.
Resistant to oils and greases.

Surface finish:

Satin.

Colour:

Black (RAL 9011).

Inserts:

Galvanised steel threaded stud (thread tolerance 6g).

Special requests:

- Upon request and for special quantities inserts can be supplied with customised lengths.
- Upon request and for special quantities inserts can be supplied in different materials.
- Upon request and for special quantities available in the colours indicated in the chart (attention: reduced range) [page 959].

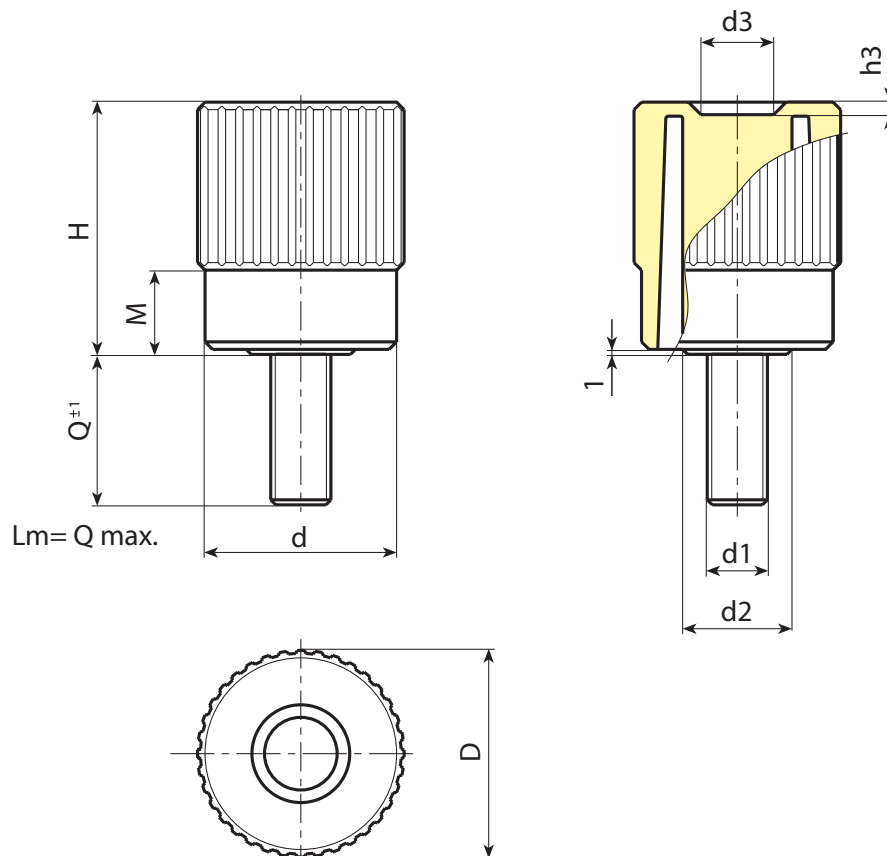

Code	Art.	D	H	M	d	d2	d3	h3	LM	d1 _{6g}	Q	g
N74140.0028	N74140.TM14X2001	42	50,5	17	38	22	15,5	2,5	90	M14	20	100

Customised stud length available for a minimum of 100 pieces.
LM = Maximum mouldable length.



N742

+135°
-30°

PA6
+G.F.

UL94
HB

RoHS
COMPLIANT

KNURLED KNOB WITH INSERT WITH SMOOTH HOLE

Materials:

Reinforced polyamide.
Resistant to oils and greases.

Surface finish:

Satin.

Colour:

Black (RAL 9011).

Inserts:

Galvanised steel insert with blind smooth bore (bore tolerance H10).

Special requests:

- Upon request and for special quantities inserts can be supplied with custom hole diameter d1.
- Upon request and for special quantities inserts can be supplied in different materials/with different coatings.
- Upon request and for special quantities available in the colours indicated in the chart [page 959].



14

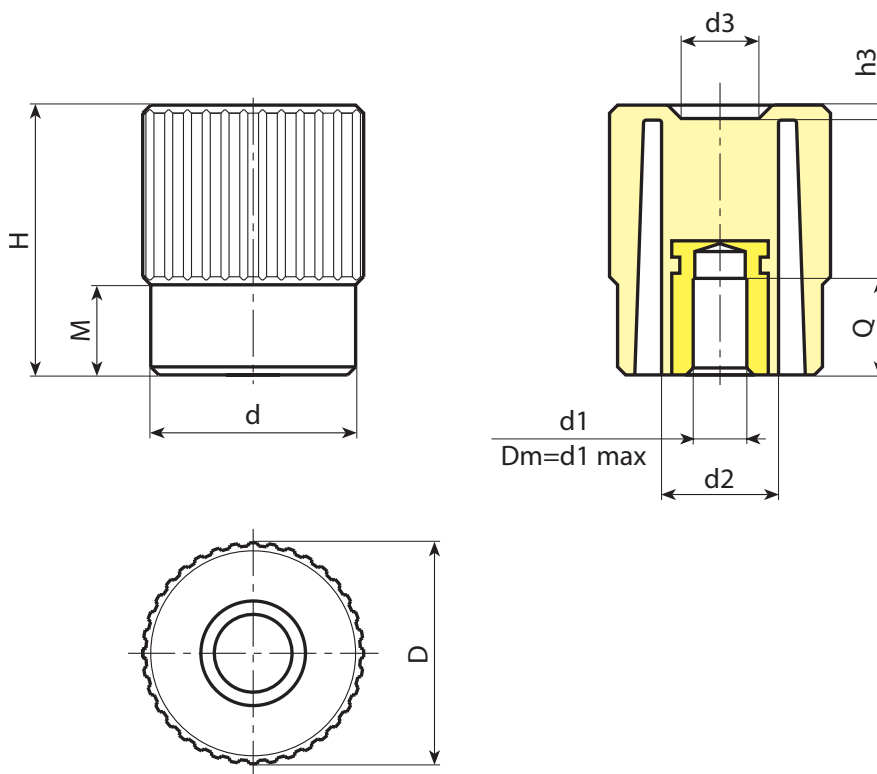

Code	Art.	D	H	M	d	d2	d3	h3	Dm	d1 _{H10}	Q	g
N74240.0006	N74240.TP0501	42	50,5	17	38	22	15,5	2,5	12	5	20	90
N74240.0002	N74240.TD1001	42	50,5	17	38	22	15,5	2,5	12	10	18	85

Attention: For a minimum of 100 pieces the diameter d1 can be produced with the requested diameter with H10 tolerance.
Dm = Maximum obtainable diameter for subsequent machining. (widening)



N775



4-LOBE CONTROL KNOB WITH THREADED HOLE INSERT

Materials:

Reinforced polyamide.
Resistant to oils and greases.

Surface finish:

Satin.

Colour:

Black (RAL 9011).

Inserts:

Galvanised steel insert with female threaded hole (thread tolerance 6H).

Special requests:

- Upon request and for special quantities inserts can be supplied in different materials.

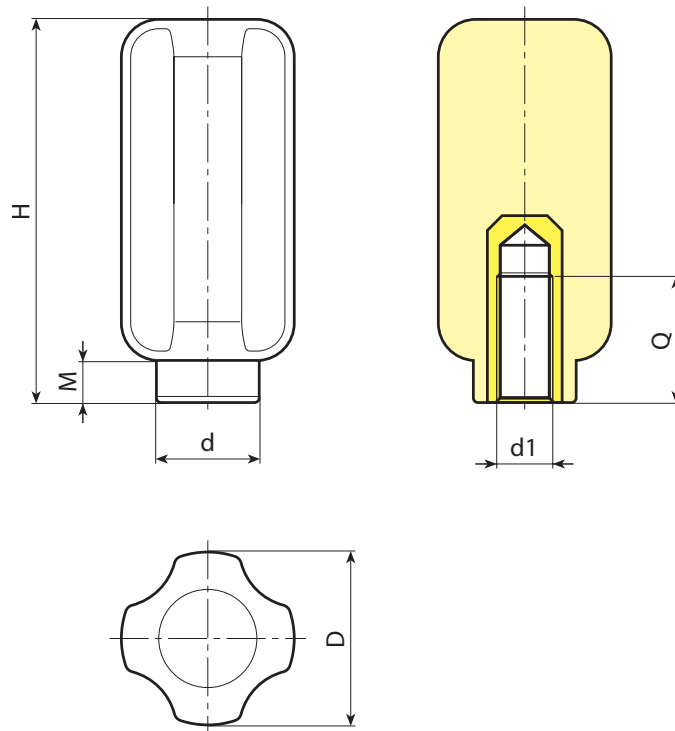

Code	Art.	D	H	M	d	d _{16H}	Q	
N77538.0001	N77538.TM0801	37	81	9	22	M8	20	94
N77538.0002	N77538.TM1001	37	81	9	22	M10	20	128
N77538.0003	N77538.TM1201	37	81	9	22	M12	30	142
N77538.0004	N77538.TM1401	37	81	9	22	M14	29	135
N77538.0007	N77538.TM1601	37	81	9	22	M16	18	116

N776

4-LOBE CONTROL KNOB WITH THREADED STUD



Materials:

Reinforced polyamide.
Resistant to oils and greases.

Surface finish:

Satin.

Colour:

Black (RAL 9011).

Inserts:

Galvanised steel threaded stud (thread tolerance 6g).

Special requests:

- Upon request and for special quantities inserts can be supplied with customised lengths.
- Upon request and for special quantities inserts can be supplied in different materials.

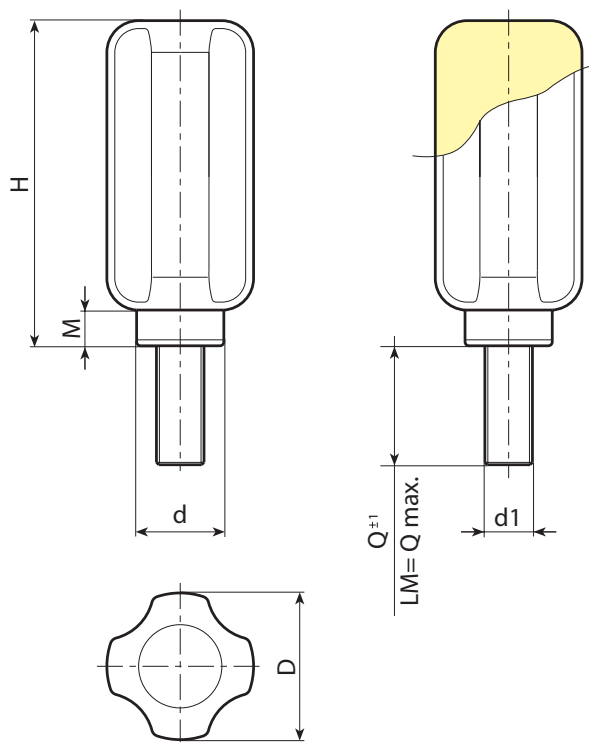

14

Code	Art.	D	H	M	d	LM	d1 _{6g}	Q	g
N77638.0002	N77638.TM10X2001	37	81	9	22	130	M10	20	127
N77638.0005	N77638.TM12X3001	37	81	9	22	130	M12	30	135

Customised stud length available for a minimum of 100 pieces.
LM = Maximum mouldable length.



N777



4-LOBE CONTROL KNOB WITH SMOOTH BORE INSERT

Materials:

Reinforced polyamide.
Resistant to oils and greases.

Surface finish:

Satin.

Colour:

Black (RAL 9011).

Inserts:

Galvanised steel insert with blind smooth bore (bore tolerance H10).

Special requests:

- Upon request and for special quantities inserts can be supplied with custom hole diameter d_1 .
- Upon request and for special quantities inserts can be supplied in different materials/with different coatings.



14

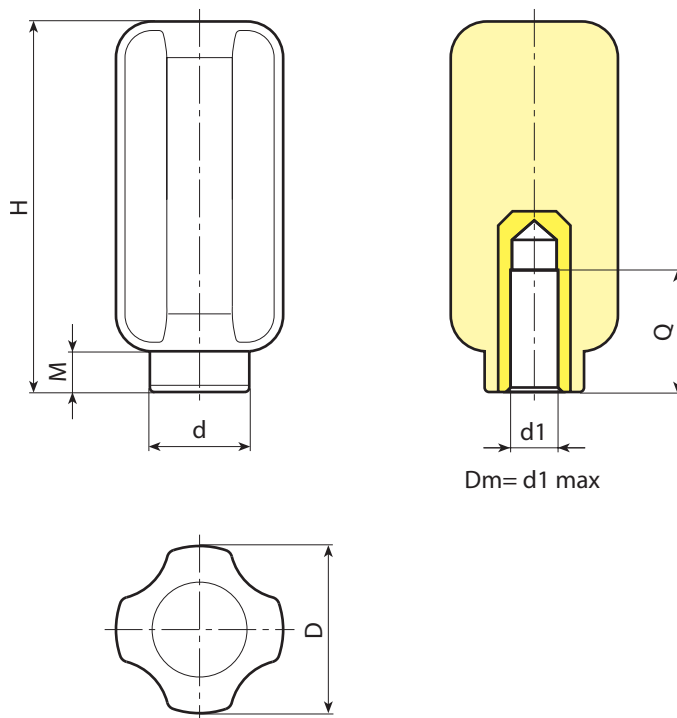

Code	Art.	D	H	M	d	Dm	d1 _{H10}	Q	
N77738.0001	N77738.TD0801	37	81	9	22	12	8	19	108
N77738.0003	N77738.TD1201	37	81	9	22	12	12	19	130

Attention: For a minimum of 100 pieces the diameter d_1 can be produced with the requested diameter with H10 tolerance.
Dm = Maximum obtainable diameter for subsequent machining (widening).



N280



PA6
+G.F.

UL94
HB

RoHS
COMPLIANT

KNURLED INDEXING KNOB WITH STEPLESS POSITIONING

Materials:

1. Stainless steel (AISI 304) fixing base with friction device seat and fixing holes.
2. Aluminium graduated flange (alloy 2011).
3. Reinforced polyamide control knob. Resistant to oils and greases.
5. PA6 cap.
6. Stainless steel fastening cap with hexagon socket (Aisi 303).
7. Fastening snap ring in stainless steel (UNI 3653).
8. Stainless steel (AISI 304) lock and friction mechanism.
10. Stainless steel self-tapping screws (AISI 303) TCS 2.9x13 for fastening the flange.

Surface finish:

- 1-6-7-8. Glossy.
2. Anodized.
- 3-5. Satin.

Colour:

1. Natural with engraved arrow.
2. Anodized black.
3. Black (RAL 9011).
5. Grey (RAL 7035 code 13).
7. Black-oxide treated.
- 6-8. Natural.

Fastening to the machine:

Fixed to the machine with 3 x M05 hex socket head cap screws (number 9 in the drawing) (DIN 912).

Graduated flange:

The standard numbering of the flange goes from 0 to 9 with 10 graduations for each unit. (100 graduations). Specific custom graduations are available for a minimum quantity of 30 pieces.

Coupling of the shaft to the knob:

The shaft is coupled to the knob by means of a shaft with keyway. Attention! The key, for technical reasons, is small in size. See attached diagram for bore/shaft dimensions.

Hole:

The shaft hole is machined to H7 tolerance. Side fixing hole is not required. The diameter of the hole is fixed and cannot be varied.

Special requests:

- Central cap available upon request in the colours indicated in the chart on [page 959].
- The flange with customised numbering is available upon request and for special quantities (30 pieces).

Features:

The main feature of this item is the possibility to continually adjust the axis of the machine to which it is coupled and to maintain the selected position. The special friction device, the heart of the mechanism, allows you to make very small, continuous movements and therefore enables fine tuning in both directions. After reaching the desired position, the friction device prevents rotation by any minor shaft-induced vibrations or movements. This system prevents accidental or involuntary rotations of the shaft.

Limitations:

If the vibrations are strong the friction device is not sufficient to block any movements. Moreover, the knob cannot support the weight of the shaft, consequently it does not replace the normal support systems (bearings, flanges, etc.). The knob cannot be installed if there is a motor drive present.

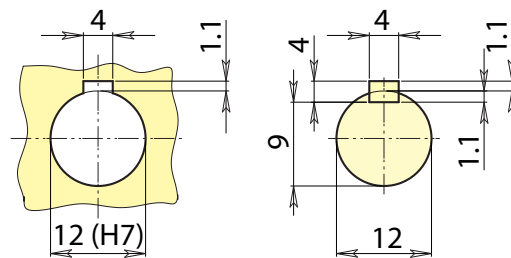

Lowered key in compliance with DIN 6885-2

N280

KNURLED INDEXING KNOB WITH STEPLESS POSITIONING

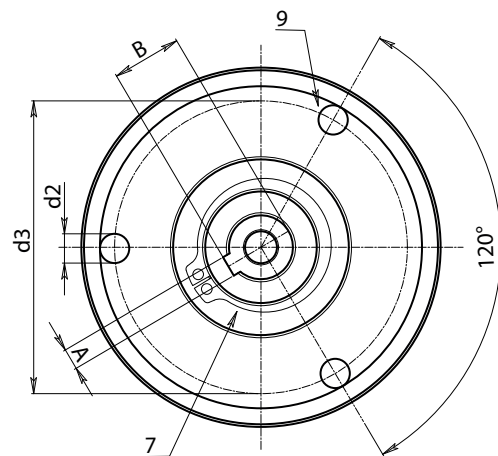
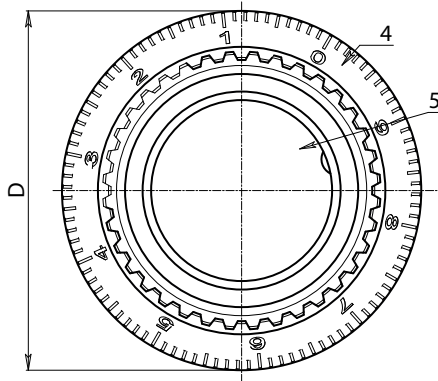
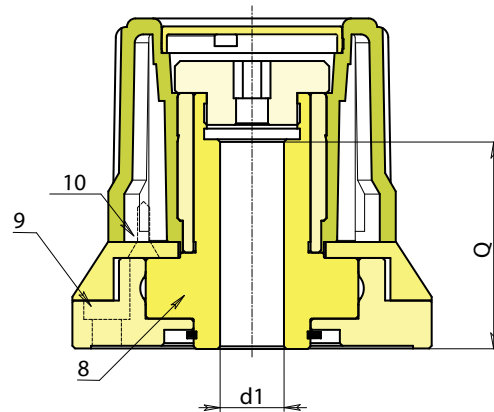
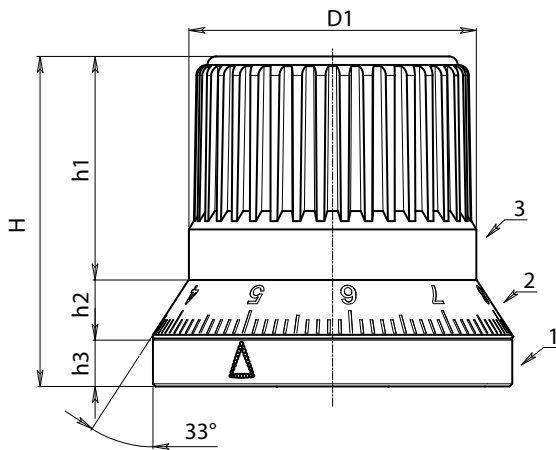

Code	Art.	D	H	D1	h1	h2	h3	d3	d2	A	B	d1H7	Q	g
N28054.0001	N28054.HNZ1000113CIN	67,5	62	54	42	11	9	55	5,5	4	13,1	12	39,5	535



N282



PA6
+G.F.

UL94
HB



KNURLED INDEXING KNOB WITH STEPLESS POSITIONING AND LOCKING ACTION

Materials:

1. Hardened steel C45 base with fixing holes.
2. Aluminium (alloy 2011) flange with laser engraved numbers.
3. Reinforced polyamide control knob. Resistant to oils and greases.
4. Stainless steel fastening cap with hexagon socket (Aisi 303).
5. PA6 cap.
6. Fastening snap ring in stainless steel (UNI 653).
7. High resistance tempered and hardened steel rotating cam shaft, with through hole and key.
8. Stainless steel knob insert (Aisi 303).
10. Stainless steel (Aisi 303) self-tapping screws TCS 2.9x19 for fastening the bush.
11. Aluminium (alloy 2011) turned unlocking pin holder bush.
12. Stainless steel (Aisi 302) pressure spring.
13. Hardened stainless steel locking roller (Aisi 52100 grade G2).
14. 2 turned stainless steel unlocking pins (Aisi 303).
15. Steel fixing screw M03x8 DIN 5933 for aluminium flange.

Surface finish:

- 1-2-4-7-8. Glossy.
- 3-5. Satin.

Colour:

1. Black-oxide treated.
2. Anodized black.
3. Black (RAL 9011).
- 4-7. Natural.

Fastening to the machine:

Fixed to the machine with 3 x M05 hex socket head cap screws (number 9 in the drawing) (DIN 912).

Hole:

The shaft hole is machined to H7 tolerance. Side fixing hole is not required. The diameter of the hole is fixed and cannot be varied.

Coupling of the shaft to the knob:

The shaft is coupled to the knob by means of a shaft with keyway. Attention! The key, for technical reasons, is small in size. See attached diagram for bore/shaft dimensions.

Graduated flange:

The flange is available in two versions:

V1

The standard numbering of the flange goes from 0 to 9 with 10 graduations for each unit. (100 graduations).

V2

Vertical line without numbers.

Attention!

Select the rotation direction (O= clockwise A=counter clockwise).

Special requests:

- Central cap available upon request in the colours indicated in the chart on [page 959].
- The flange with customised numbering is available upon request and for special quantities (50 pieces).

Limitations:

The knob is not capable of supporting the weight of the shaft to which it is coupled; consequently it does not replace the normal support systems (bearings, flanges, etc.).

The knob cannot be installed if there is a motor drive present.

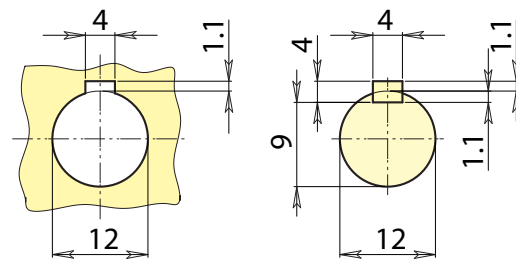

Lowered key in compliance with DIN 6885-2

N282

KNURLED INDEXING KNOB WITH STEPLESS POSITIONING AND LOCKING ACTION

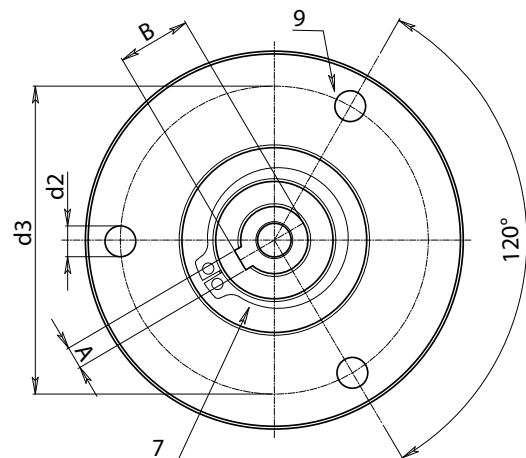
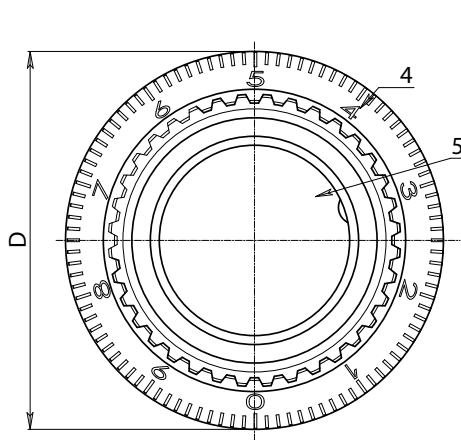
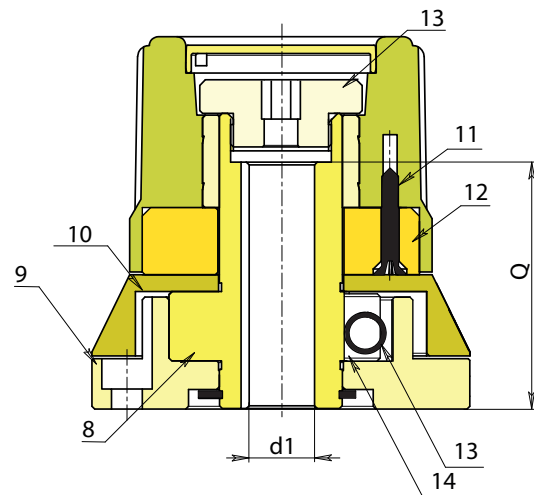
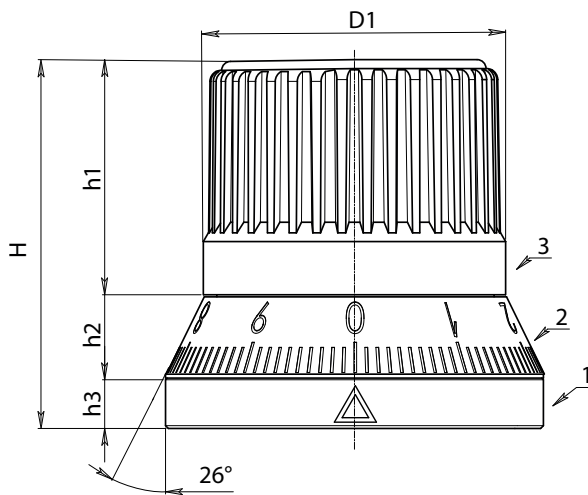
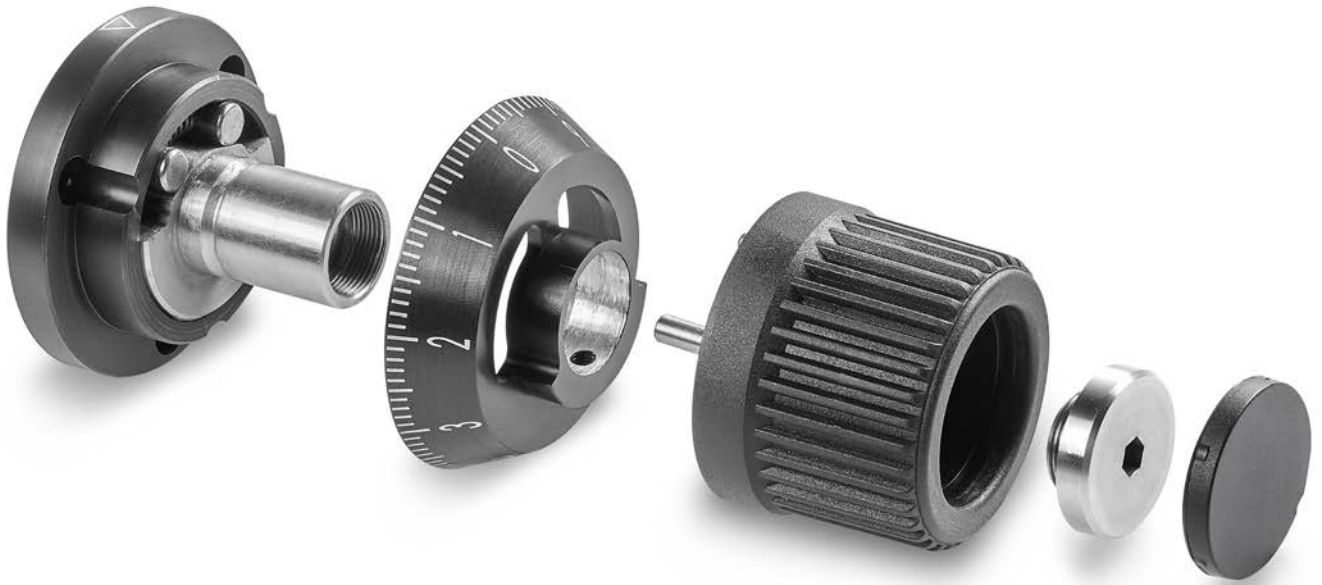

Code	Art.	D	H	D1	h1	h2	h3	d3	d2	A	B	d1 _{H7}	Q	
N28254.0003	N28254.SBZ200101V1	67,5	66	54	42	15	9	55	5,5	4	13,1	12	44	625

N290



Aisi 303

PA6 +G.F.

UL94 HB



STAINLESS STEEL INDEXED CONTROL KNOB WITH HANDLE

Material:

5. Reinforced polyamide handle. Resistant to oils and greases (M138).
1. Turned fixing cap in stainless steel (Aisi 303) with hexagon for key.
2. Turned knob body in stainless steel (Aisi 303) with 60-position tootinging (6° indexing).
3. Stainless steel spring (Aisi 302).
4. Fixing base in stainless steel (Aisi 303) with 60-position tootinging.
6. Fastening snap ring in stainless steel, (Aisi 420) DIN 471.
7. Turned handle holder stem in stainless steel, (Aisi 303).
8. Turned bush with hole and key to connect to the shaft, in stainless steel (Aisi 303) and 60-position tootinging.



Surface finish:

5. Satin.
- 1-2-4-7-8. Turned with low roughness.

Colour:

5. Black (RAL 9011).
- 1-2-4-7-8. Natural.

Fastening to the machine:

First of all, the knob must be dismantled, unscrewing the cap (1) and removing the spring and knob body. Then secure the base (4) to the equipment by means of the three M5 countersunk head screws UNI 5933 (not supplied), after first inserting the shaft in hole d1 and then inserting the key. Then re-assemble the knob body (2), the spring (3) and tighten everything through cap (1).



Special requests:

- Upon request and for special quantities the knob can be supplied in different materials.
- Upon request and for special quantities a graduated scale can be engraved on the cylindrical side of the knob body.

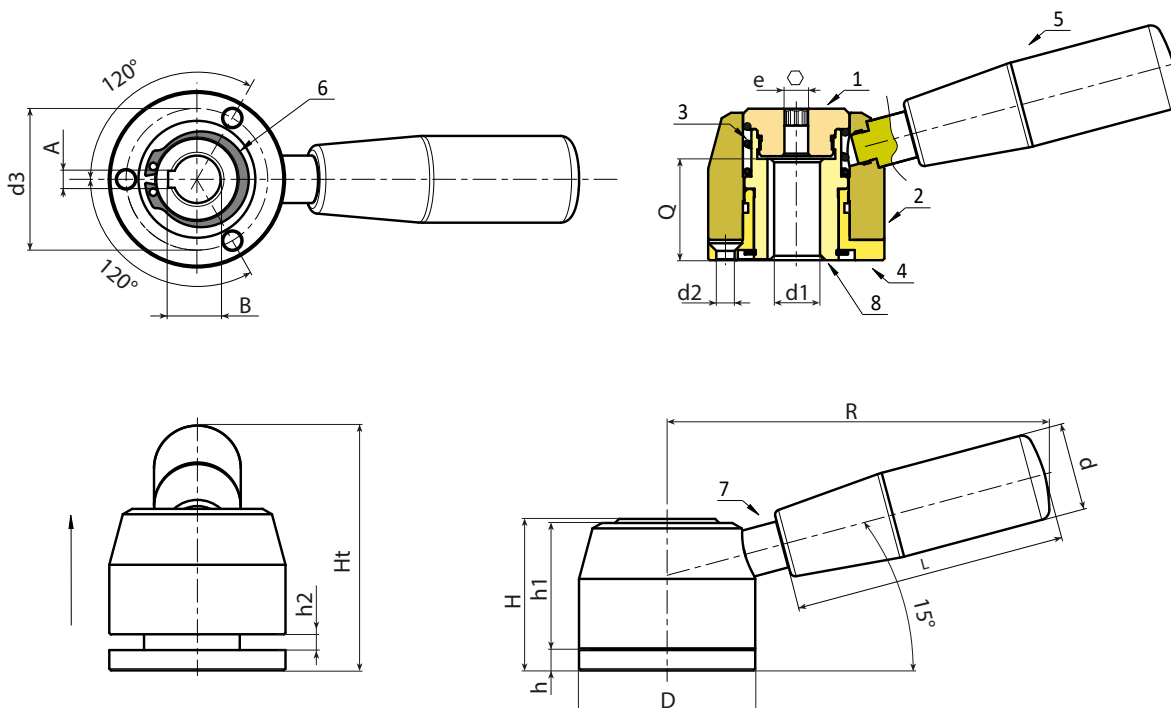

Code	Art.	D	H	Ht	h	h1	h2	R	d	L	d2	e	d3	AH9	B	d1H7	Q	g
N29052.0001	N29052.IND14CIN	52	44	75	6	37,5	5	112	26	79	5,5	6	41.8	5	15.5	14	30	680

N246

KNURLED KNOB WITH INSERT WITH SMOOTH HOLE



Materials:

Reinforced polyamide.
Resistant to oils and greases.

Surface finish:

Satin.

Colour:

Black (RAL 9011).

Cap:

Central cap in grey polyamide (RAL 7035).

Inserts:

Galvanised steel insert with smooth through bore (tolerance H10).

Notes:

(*) Side NFLAN flange fixing (optional).

Special requests:

- Upon request and for special quantities inserts can be supplied with custom hole diameter d1.
- Upon request and for special quantities inserts can be supplied in different materials/with different coatings.
- Upon request and for special quantities available in the colours indicated in the chart (attention: reduced range) [page 959].

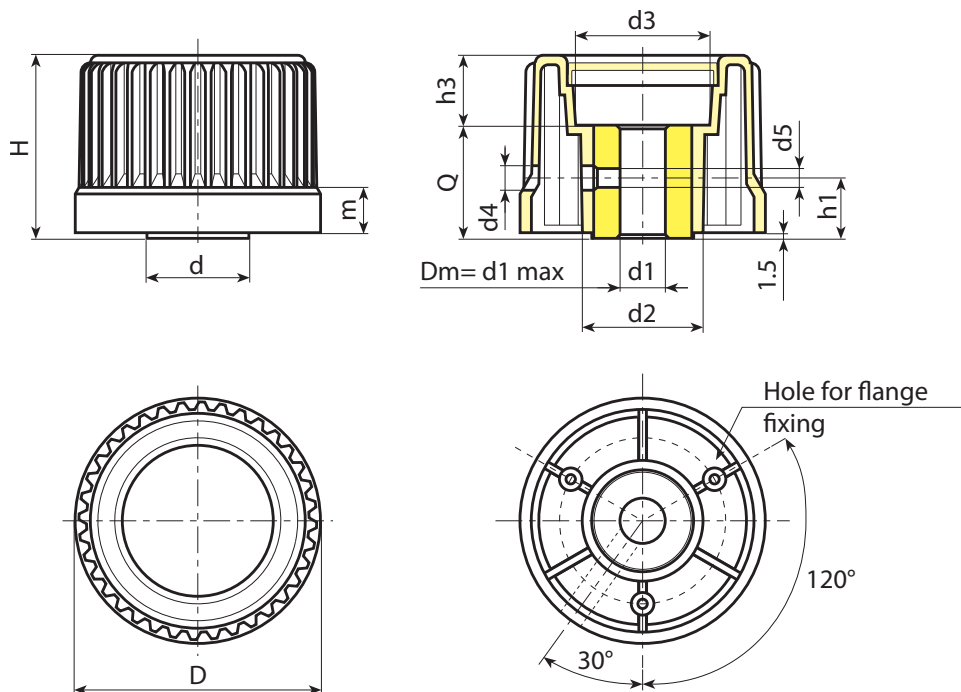

Code	Art.	D	H	m	d	d2	d3	d4	d5	h1	h3	Dm	d1 _{H10}	Q	
N24630.0001	N24630.TD060113(*)	30	31,5	11,5	20	-	18	4,5	M4	16	5,5	12	6	26	74
N24630.0005	N24630.TD080113(*)	30	31,5	11,5	20	-	18	5,5	M5	16	5,5	12	8	26	70
N24643.0004	N24643.TD080113	43	37,5	11,5	22	27,5	23	5,5	M5	16	13,5	12	8	24	89
N24654.0001	N24654.TD080113	54	43,5	12	26	32	31	5,5	M5	16	13,5	14	8	30	180
N24654.0005	N24654.TD120113	54	43,5	12	26	32	31	6,5	M6	16	13,5	14	12	30	140
N24665.0001	N24665.TD080113	65	48,5	12	27	32	36	5,5	M5	16	18,5	16	8	30	180
N24665.0007	N24665.TD120113	65	48,5	12	27	32	36	6,5	M6	16	18,5	16	12	30	165
N24665.0009	N24665.TD140113	65	48,5	12	27	32	36	6,5	M6	16	18,5	16	14	30	156
N24678.0002	N24678.TD080113	78	55,5	12,5	31	36	50	6,5	M6	18	23,5	18	8	32	260

Attention: For a minimum of 100 pieces the diameter d1 can be produced with the requested diameter with H10 tolerance.
Dm = Maximum obtainable diameter for subsequent machining (widening).



N248

KNURLED CONTROL KNOB WITH THREADED HOLE INSERT



PA6
+G.F.

UL94
HB



Materials:

Reinforced polyamide.
Resistant to oils and greases.

Surface finish:

Satin.

Colour:

Black (RAL 9011).

Cap:

Central cap in grey polyamide (RAL 7035).

Inserts:

Galvanised steel insert with threaded through hole (thread tolerance 6H).

Notes:

(*) Side NFLAN flange fixing (optional).

Special requests:

- Upon request and for special quantities inserts can be supplied with custom hole diameter d1.
- Upon request and for special quantities inserts can be supplied in different materials/with different coatings.
- Upon request and for special quantities available in the colours indicated in the chart (attention: reduced range) [page 959].

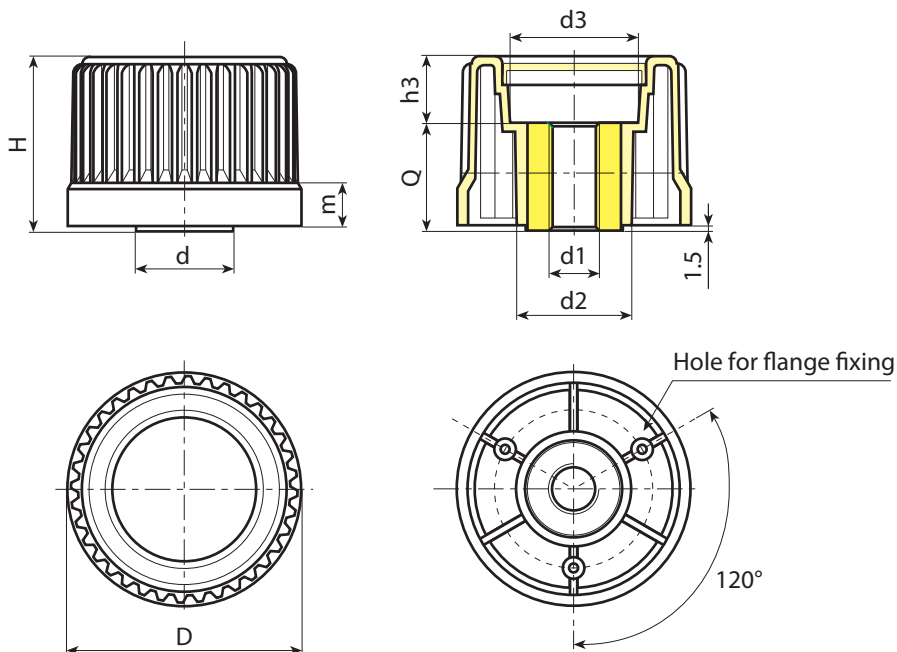

Code	Art.	D	H	m	d	d2	d3	h3	d1 _{6H}	Q	
N24830.0001	N24830.TM0801 (*)	30	31,5	11,5	20	20	18	5,5	M8	26	79
N24843.0002	N24843.TM1001	43	37,5	11,5	22	27,5	23	13,5	M10	24	85
N24854.0002	N24854.TM1201	54	43,5	12	26	32	31	13,5	M12	30	155
N24865.0001	N24865.TM1201	65	48,5	12	27	32	36	18,5	M12	30	180
N24878.0001	N24878.TM1401	78	55,5	12,5	31	36	50	23,5	M14	32	270

Threaded holes already provided: N248-30: M08-M10-M12

Threaded holes already provided: N248-43: M08-M10-M12

Threaded holes already provided: N248-54: M08-M10-M12

Threaded holes already provided: N248-65: M10-M12-M14

Threaded holes already provided: N248-78: M12-M14-M16

Attention: for a minimum of 100 pieces the diameter d1 can be produced with the requested dimensions.



N245

KNURLED CONTROL KNOB WITH THREADED STUD



Materials:

Reinforced polyamide.
Resistant to oils and greases.

Surface finish:

Satin.

Colour:

Black (RAL 9011).

Cap:

Central cap in grey polyamide (RAL 7035).

Inserts:

Galvanised steel threaded stud (thread tolerance 6g).

Notes:

(*) Side NFLAN flange fixing (optional).

Special requests:

- Upon request and for special quantities inserts can be supplied with customised lengths.
- Upon request and for special quantities inserts can be supplied in different materials/with different coatings.
- Upon request and for special quantities available in the colours indicated in the chart (attention: reduced range) [page 959].

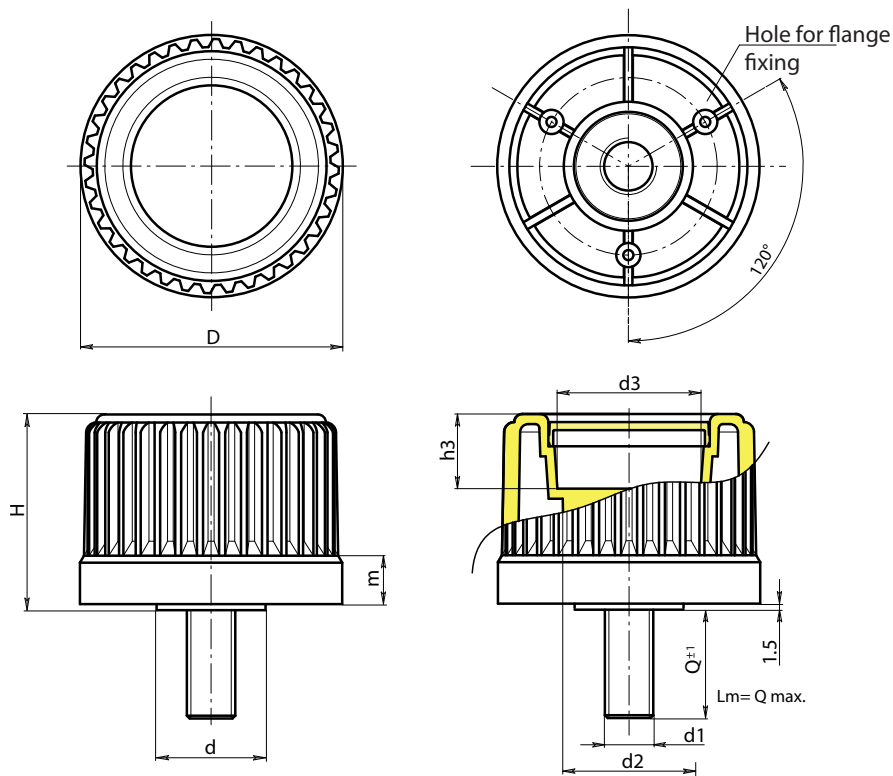

Code	Art.	D	H	m	d	d2	d3	h3	LM	d1 _{6g}	Q	g
N24530.0002	N24530.TM10X200113(*)	30	31,5	11,5	20	20	18	5,5	80	M10	20	40
N24543.0001	N24543.TM12X300113	43	37,5	11,5	22	27,5	23	13,5	90	M12	30	-
N24554.0001	N24554.TM12X300113	54	43,5	12	26	32	31	13,5	100	M12	30	-
N24565.0001	N24565.TM16X300113	65	48,5	12	27	32	36	18,5	120	M16	30	-
N24578.0001	N24578.TM16X300113	78	55,5	12,5	31	36	50	23,5	120	M16	30	-

LM = maximum mouldable length.
Customised stud length available for a minimum of 200 pieces.



W995



KNURLED ALUMINIUM CONTROL KNOB WITH NUMBERS

Materials:

Aluminium (alloy AL 6060).

Surface finish:

Turned with low roughness.

Colour:

Anodized black.

Cap:

Central cap in grey polyamide (RAL 7035 code 13).

Grub screw:

Stainless steel 304 grub screw M05x6 with cup point DIN 916.

Hole:

Smooth through hole, remachined with H7 tolerance.

Graduations and numbers:

Graduations and numbers engraved on the smooth part of the knob.

Natural aluminium colour.

Z1= Scale 0-10 with 20 graduations.

Z2= Scale 0-20 with 20 graduations.

Special Requests:

- Upon request and for special quantities control knobs can be supplied to customer's drawing with hole diameter d1.

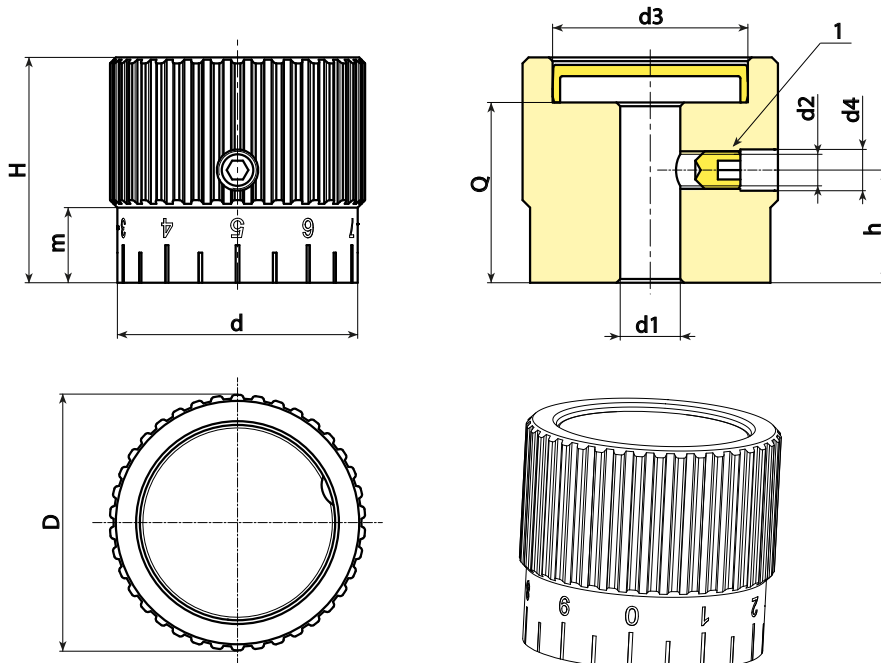

Code	Art.	D	d	H	m	h	d2	d3	d4	d1 _{H7}	Q	g
W99534.0004	W99534.AD0813Z1	34	32	30	10	15	M5	26	5.5	8	24	100

Attention: For a minimum of 50 pieces the diameter d1 can be customised (hole tolerance H7).



NFLAN

FLANGE FOR CONTROL KNOB (N245-N246-N248)



Materials:

Reinforced polyamide.
Resistant to oils and greases.

Surface finish:

Satin.

Colour:

Grey (RAL 7035 cod. 13).

Scale:

Black pad-printed.

Fixing screws:

3 galvanised self-tapping screws 2.9x9.5
UNI6954.

Special requests:

- Upon request the flange can be supplied in black. With white graduated scale.
- Upon request and for special quantities graduated scale to customer's drawing.

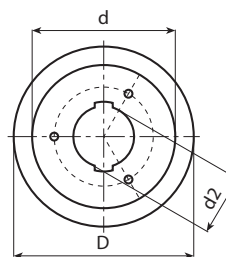
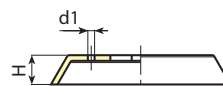

Type: Neutral base

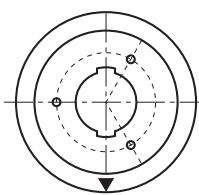

Type: Z1
Arrow

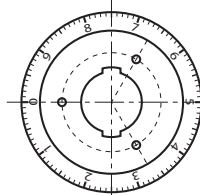

Type: Z2
100 divisions
0:9

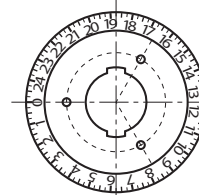

Type: Z3
100 divisions
0:24

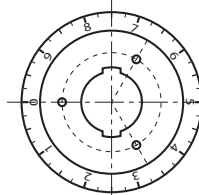

Type: Z4
40 divisions
0:9

Code	Art.	D	H	d/N246/ N248	d1	d2	TYPE	
NFLAN.T3013	NFLAN.T3013	38	7	30	-	20	-	5
NFLAN.0005	NFLAN.T3013Z1	38	7	30	-	20	Z1	5
NFLAN.T4313	NFLAN.T4313	53,5	9	43	3,5	23,5	-	8
NFLAN.0009	NFLAN.T4313Z1	53,5	9	43	3,5	23,5	Z1	8
NFLAN.T5413	NFLAN.T5413	67	11	54	3,5	27,5	-	13
NFLAN.0012	NFLAN.T5413Z1	67	11	54	3,5	27,5	Z1	13
NFLAN.T6513	NFLAN.T6513	80	13	65	3,5	27,5	-	20
NFLAN.0015	NFLAN.T6513Z1	80	13	65	3,5	27,5	Z1	20
NFLAN.0016	NFLAN.T6513Z2	80	13	65	3,5	27,5	Z2 - 0:9 100	20
NFLAN.0017	NFLAN.T6513Z3	80	13	65	3,5	27,5	Z3 - 0:24 100	20
NFLAN.0018	NFLAN.T6513Z4	80	13	65	3,5	27,5	Z4 - 0:9 40	20
NFLAN.T7813	NFLAN.T7813	93	13	78	3,5	31,5	-	27
NFLAN.0019	NFLAN.T7813Z1	93	13	78	3,5	31,5	Z1	27

N250



PA6
+G.F.

UL94
HB



KNURLED KNOB WITH INSERT WITH SMOOTH HOLE AND FLANGE

Materials:

Control knob and flange:

Reinforced polyamide.
Resistant to oils and greases.

Surface finish:

Control knob and flange:

Satin.

Colour:

Knob:

Black (RAL 9011 code 01).

Flange and cap:

Black (RAL 9011 code 01).

Grey (RAL 7035 code 13).

Cap:

Central cap in polyamide.

Inserts:

Galvanised steel insert with smooth through bore (tolerance H10).

Fixing screws:

3 galvanised self-tapping screws 2.9x9.5 UNI6954.

Scale:

Black pad-printed on grey flange;

Grey pad-printed on black flange;

For flange with arrow only: version Z1.

For flange with numbers from 0 to 9 with 100 graduations: version Z2.

Special requests:

- Upon request and for special quantities inserts can be supplied with custom hole diameter d1.
- Upon request and for special quantities inserts can be supplied in different materials/with different coatings.
- Upon request and for special quantities available in the colours indicated in the chart [page 959].

14



N250



KNURLED KNOB WITH INSERT WITH SMOOTH HOLE AND FLANGE

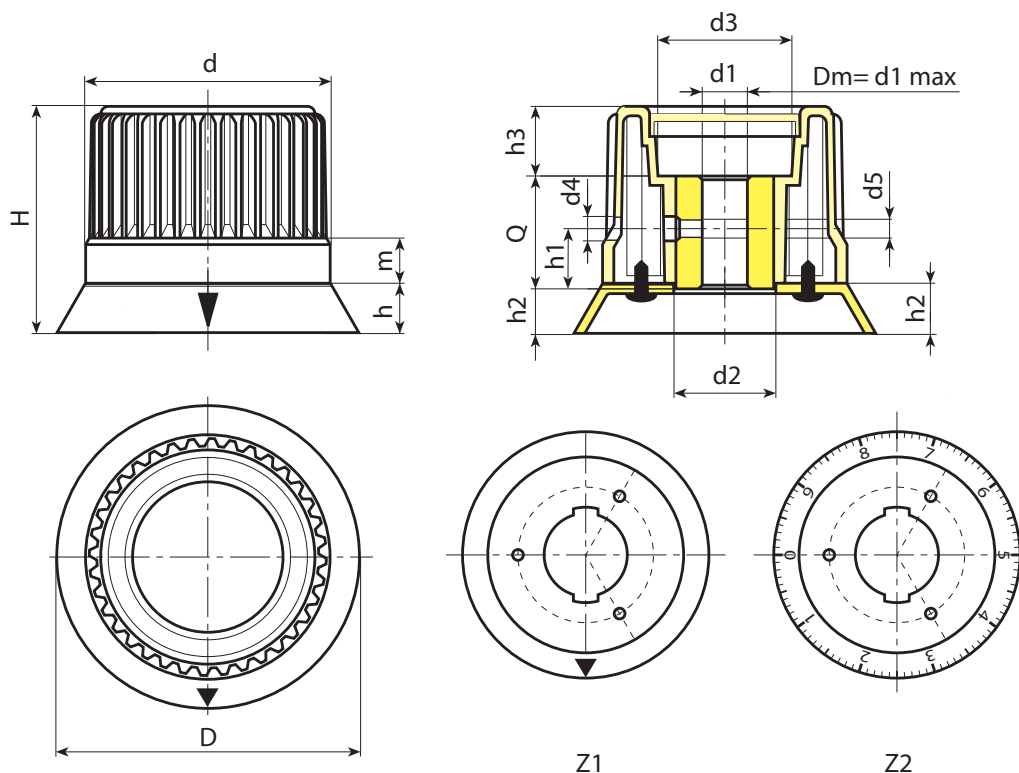

Version with grey (RAL 7035 code no. 13) flange and cap, and black arrow.

Code	Art.	D	H	h	m	d	d2	d3	d4	d5	h1	h2	h3	Dm	d1 _{H10}	Q	g
N25030.0001	N25030.TD060113Z1	38	37	7	11,5	30	20	18	4,5	M4	16	5,5	5,5	12	6	26	85
N25043.0002	N25043.TD080113Z1	53,5	45	9	11,5	43	23,5	23	5,5	M5	16	7,5	13,5	12	8	24	98
N25054.0001	N25054.TD080113Z1	67	53	11	12	54	27,5	31	5,5	M5	16	9,5	13,5	14	8	30	170
N25065.0001	N25065.TD080113Z1	80	60	13	12	65	27,5	36	5,5	M5	16	11,5	19	16	8	30	190
N25078.0001	N25078.TD080113Z1	93	67	13	12,5	78	31,5	50	6,5	M6	18	11,5	23,5	18	8	32	290

Version with black flange and cap, and grey arrow.

Code	Art.	D	H	h	m	d	d2	d3	d4	d5	h1	h2	h3	Dm	d1 _{H10}	Q	g
N25030.0003	N25030.TD0601Z1	38	37	7	11,5	30	20	18	4,5	M4	16	5,5	5,5	12	6	26	85
N25043.0004	N25043.TD0801Z1	53,5	45	9	11,5	43	23,5	23	5,5	M5	16	7,5	13,5	12	8	24	98
N25054.0003	N25054.TD0801Z1	67	53	11	12	54	27,5	31	5,5	M5	16	9,5	13,5	14	8	30	170
N25065.0003	N25065.TD0801Z1	80	60	13	12	65	27,5	36	5,5	M5	16	11,5	19	16	8	30	190
N25078.0003	N25078.TD0801Z1	93	67	13	12,5	78	31,5	50	6,5	M6	18	11,5	23,5	18	8	32	290

Version with grey (RAL 7035 code no. 13) flange and cap, and black graduated scale.

Code	Art.	D	H	h	m	d	d2	d3	d4	d5	h1	h2	h3	Dm	d1 _{H10}	Q	g
N25030.0002	N25030.TD060113Z2	38	37	7	11,5	30	20	18	4,5	M4	16	5,5	5,5	12	6	26	85
N25043.0003	N25043.TD080113Z2	53,5	45	9	11,5	43	23,5	23	5,5	M5	16	7,5	13,5	12	8	24	98
N25054.0002	N25054.TD080113Z2	67	53	11	12	54	27,5	31	5,5	M5	16	9,5	13,5	14	8	30	170
N25065.0002	N25065.TD080113Z2	80	60	13	12	65	27,5	36	5,5	M5	16	11,5	19	16	8	30	190
N25078.0002	N25078.TD080113Z2	93	67	13	12,5	78	31,5	50	6,5	M6	18	11,5	23,5	18	8	32	290

Version with black flange and cap, and grey graduated scale.

Code	Art.	D	H	h	m	d	d2	d3	d4	d5	h1	h2	h3	Dm	d1 _{H10}	Q	g
N25030.0004	N25030.TD0601Z2	38	37	7	11,5	30	20	18	4,5	M4	16	5,5	5,5	12	6	26	85
N25043.0005	N25043.TD0801Z2	53,5	45	9	11,5	43	23,5	23	5,5	M5	16	7,5	13,5	12	8	24	98
N25054.0004	N25054.TD0801Z2	67	53	11	12	54	27,5	31	5,5	M5	16	9,5	13,5	14	8	30	170
N25065.0004	N25065.TD0801Z2	80	60	13	12	65	27,5	36	5,5	M5	16	11,5	19	16	8	30	190
N25078.0004	N25078.TD0801Z2	93	67	13	12,5	78	31,5	50	6,5	M6	18	11,5	23,5	18	8	32	290

Attention: For a minimum of 100 pieces the diameter d1 can be produced with the requested diameter with H10 tolerance.
Dm = Maximum obtainable diameter for subsequent machining (widening).





TAILOR SUPPLIES TO YOUR REQUIREMENTS.

