



**GROUP - 07**



## LOCKING HANDWHEELS

### BOTECO Locking Handwheels

The locking handwheels are of major importance in the Boteco range of products. The G730 series of 4-lobe handwheels and variants, in particular, is a key series that has characterised our range of products since the '80s. This product has become one of the most sold and loved as even the geometry of the handwheel can be customized. The available variants are in continual expansion, as are the customization possibilities. For detailed information on the specifications of each individual product please consult the technical sheet.

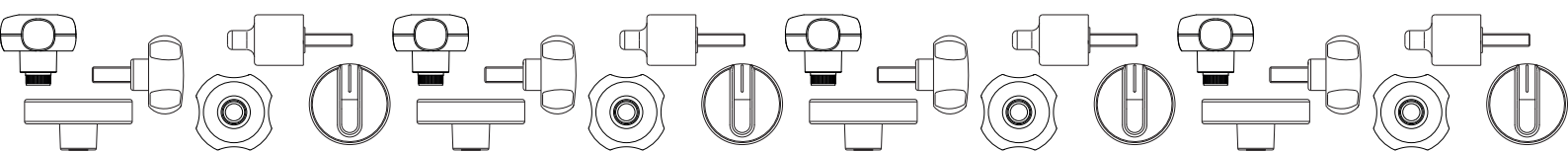

# G630



## 4 LOBE HANDWHEEL WITH INDEXED INSERT (PUSH TO USE) AND THREADED INSERT

### Materials:

(3-4) Special high resistance glass fiber reinforced technopolymer.  
Resistant to oils and greases.

### Surface finish:

Satin.

### Colour:

(3-4) Black. (RAL 9011).

### Central fixing button:

(1) Red polyamide button (RAL 3000 code 16).

### Alternative handwheel and button colour:

Orange (RAL 2004 code 02).  
Blue (RAL 5015 code 07).  
Yellow (RAL 1021 code 10).  
Red (RAL 3000 code 16).  
Green (RAL 6024 code 17).  
Grey (RAL 7035 cod. 13).  
Black (RAL 9001 code 01).

### Inserts:

Brass insert with female threaded hole (thread tolerance 6H).

### Spring:

Stainless steel spring (Aisi 302).

### Special requests:

- Upon request and for special quantities inserts can be supplied in different materials.
- Upon request and for special quantities available in the colours indicated in the chart [page 959].



07

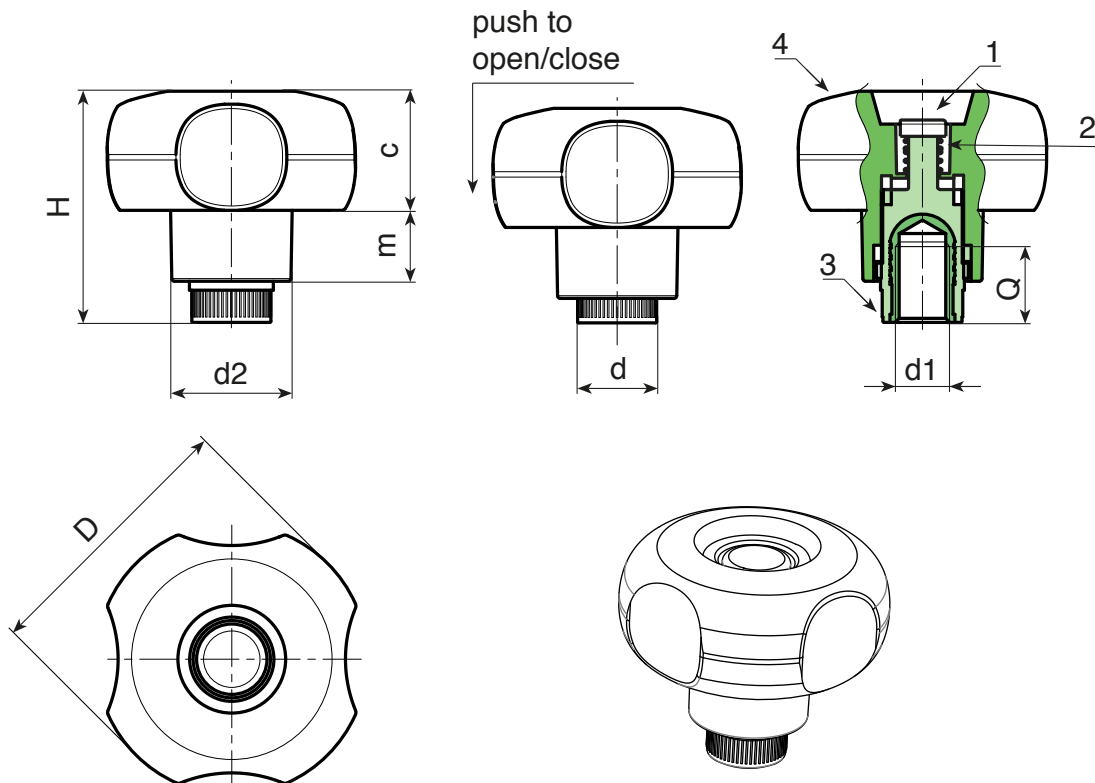

Code	art.	D	H	d2	d	m	c	d1 <sub>6H</sub>	Q	
G63050.0001	G63050.TM060116	49	42.5	22	15	13	22	M6	14	37
G63050.0004	G63050.TM080116	49	42.5	22	15	13	22	M8	14	37
G63050.0006	G63050.TM100116	49	42.5	22	15	13	22	M10	14	38

## 4 LOBE HANDWHEEL WITH INDEXED INSERT (PUSH TO USE) AND MALE THREAD

### Materials:

(3-4) Special high resistance glass fiber reinforced technopolymer.  
Resistant to oils and greases.

### Surface finish:

Satin.

### Colour:

(3-4) Black. (RAL 9011).

### Central fixing button:

(1) Red polyamide button (RAL 3000 code 16).

### Alternative handwheel and button colour:

Orange (RAL 2004 code 02).  
Blue (RAL 5015 code 07).  
Yellow (RAL 1021 code 10).  
Red (RAL 3000 code 16).  
Green (RAL 6024 code 17).  
Grey (RAL 7035 cod. 13).  
Black (RAL 9001 code 01).

### Inserts:

Galvanised steel threaded stud (thread tolerance 6g).

### Spring:

Stainless steel spring (Aisi 302).

### Special requests:

- Upon request and for special quantities inserts can be supplied with customised lengths.
- Upon request and for special quantities inserts can be supplied in different materials.
- Upon request and for special quantities available in the colours indicated in the chart [page 959].

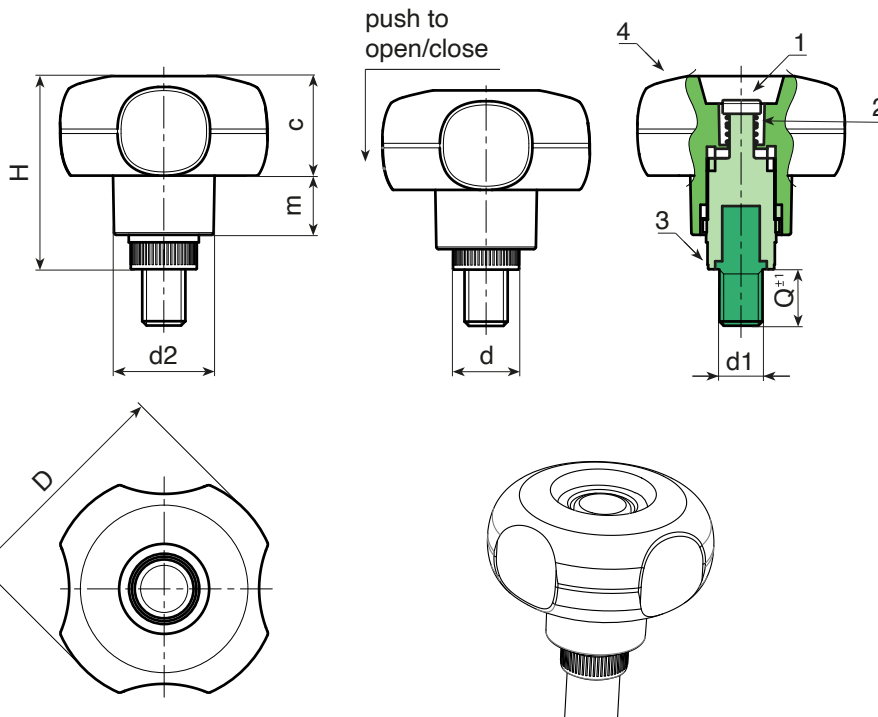

Code	art.	D	H	d2	d	m	c	LM	d1 <sub>6g</sub>	Q	
G63250.0002	G63250.TM06X300116	49	42.5	22	15	13	22	90	M6	30	-
G63250.0005	G63250.TM08X400116	49	42.5	22	15	13	22	90	M8	40	-
G63250.0007	G63250.TM10X500116	49	42.5	22	15	13	22	90	M10	50	-

LM = Maximum mouldable length.

Threaded stud length on request, with a minimum quantity of 250 pieces.

# G130

## “EUROMODEL” KNURLED KNOB WITH CAP



### Materials:

Reinforced polyamide. Resistant to oils and greases.

### Surface finish:

Satin.

### Handwheel colour:

Black (RAL 9011).

### Central cap:

Central cap in grey polyamide (RAL 7035 code 13) with black polyamide support ring. Push fit assembling. Removable.

### Alternative cap colours:

Orange (RAL 2004 code 02).  
 Blue (RAL 5015 code 07).  
 Yellow (RAL 1021 code 10).  
 Red (RAL 3000 code 16).  
 Green (RAL 6024 code 17).  
 Black (RAL 9011 code 01).

### Inserts:

#### Version TD:

Galvanised steel insert with smooth through bore (tolerance H10).

#### Version TM:

Galvanised steel insert with threaded through hole (tolerance hole 6H).

### Fixing hole D2:

#### Version TD:

Fixing threaded hole.

#### Version TM:

None.

### Special requests:

- Upon request and for special quantities inserts can be supplied with custom hole diameter d1.
- Upon request and for special quantities inserts can be supplied in different materials.
- Upon request and for special quantities available in the colours indicated in the chart [page 959].



07

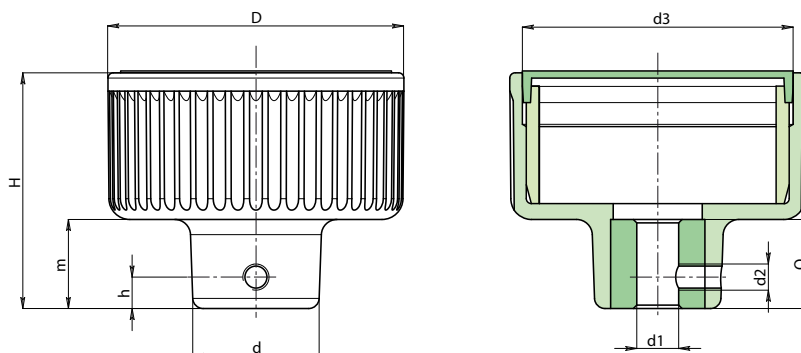

Version TD: with smooth through hole.

Code	art.	D	d	H	m	h	d2	d3	dm	d1 <sub>H10</sub>	Q	g
G130057.0001	G130057.TD080113	57	24	46	17	6	M5	52	12	8	16	105
G130072.0001	G130072.TD080113	72	28	53	21	6	M5	67	12	8	20	165
G130094.0002	G130094.TD100113	94	36	58	24	6	M5	87	15	10	24	376

Attention: for a minimum of 50 pieces the diameter d1 can be produced with the requested dimensions (H10 tolerance)  
 Dm = Maximum obtainable diameter for subsequent machining (widening).

Version TM with threaded through hole

Code	art.	D	d	H	m	h	d2	d3	dm	d1 <sub>6H</sub>	Q	g
G130057.0002	G130057.TM080113	57	24	46	17	-	-	52	12	M8	16	105
G130072.0002	G130072.TM100113	72	28	53	21	-	-	67	12	M10	20	165
G130094.0003	G130094.TM120113	94	36	58	24	-	-	87	15	M12	24	376

Attention: for a minimum of 50 pieces the diameter d1 can be produced with the requested dimensions.

# G210

## PUSH-FIT INDICATOR KNOB WITH HALFMOON HOLE



**Materials:**

Reinforced copolymer polypropylene.

**Surface finish:**

Satin.

**Colour:**

Black (RAL 9011).

**Pointer Colour:**

White line obtained by pad printing.

**Hole:**

Halfmoon-shaped blind smooth hole obtained by moulding.

**Assembly:**

Push-fit.

**Special requests:**

- None.

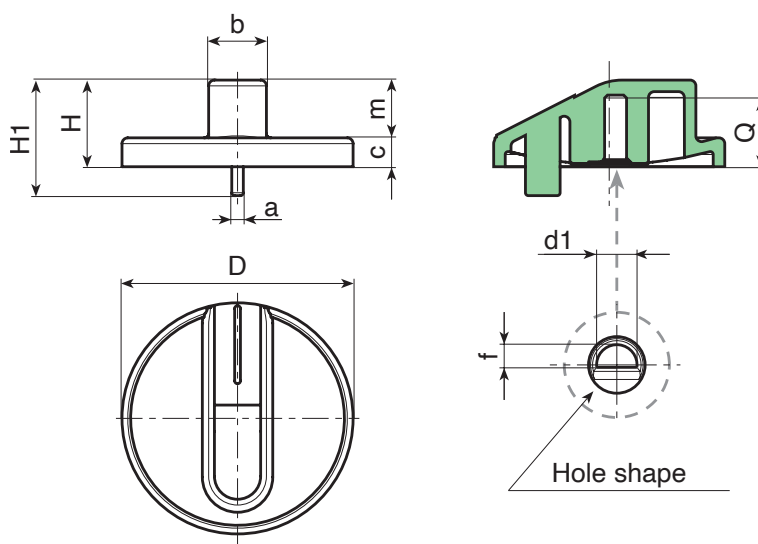

Code	art.	D	H	H1	a	b	c	m	f	d1	Q	g
G210040.0001	G210040.TG0601Z1	39.5	15	20	2	9.5	5	10	3.8	6	12	5



# G650



## 6-LOBE HANDWHEEL WITH CAP AND THREADED INSERT

### Materials:

Reinforced polyamide.  
Resistant to oils and greases.

### Surface finish:

Satin.

### Colour:

Black (RAL 9011).

### Central Cap:

Grey polyamide (RAL 7035). 13).

### Alternative Cap colours:

Orange (RAL 2004 code 02).  
Blue (RAL 5015 code 07).  
Yellow (RAL 1021 code 10).  
Red (RAL 3000 code 16).  
Green (RAL 6024 code 17).  
Black (RAL 9011 code 01).

### Inserts:

Brass insert with threaded through hole (thread tolerance 6H).

### Special Requests:

- Upon request and for special quantities inserts can be supplied in different materials.
- Upon request and for special quantities available in the colours indicated in the chart [page 959].

### PAD PRINTING SERVICE

Upon request and for special quantities caps can be supplied with custom pad printing.



07

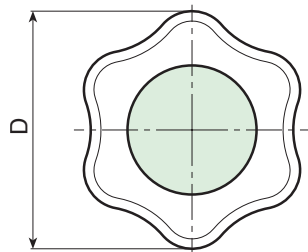
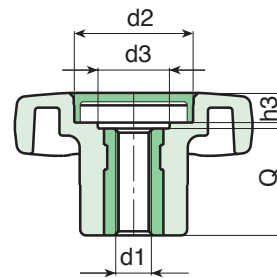
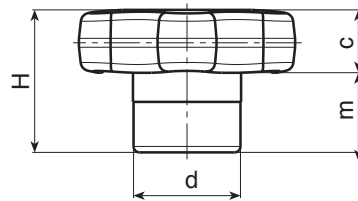
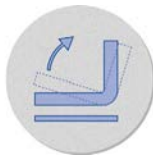

Code	art.	D	H	d	m	c	d2	d3	h3	d1 <sub>6H</sub>	Q	g
G65040.0001	G65040.TM0601	40	24	18	10.5	13.5	20	13	6	M6	18	18
G65040.0005	G65040.TM0801	40	24	18	10.5	13.5	20	13	6	M8	18	19
G65040.0010	G65040.TM1001	40	24	18	10.5	13.5	20	13	6	M10	18	20

# G651

## 6-LOBE HANDWHEEL WITH CAP AND THREADED STUD



### Materials:

Reinforced polyamide.  
Resistant to oils and greases.

### Surface finish:

Satin.

### Colour:

Black (RAL 9011).

### Central Cap:

Grey polyamide (RAL 7035). 13).

### Alternative Cap colours:

Orange (RAL 2004 code 02).  
Blue (RAL 5015 code 07).  
Yellow (RAL 1021 code 10).  
Red (RAL 3000 code 16).  
Green (RAL 6024 code 17).  
Black (RAL 9011 code 01).

### Inserts:

Galvanised steel threaded stud (thread tolerance 6g).

### Special Requests:

- Upon request and for special quantities inserts can be supplied with customised lengths.
- Upon request and for special quantities inserts can be supplied in different materials.
- Upon request and for special quantities available in the colours indicated in the chart [page 959].

### PAD PRINTING SERVICE

Upon request and for special quantities caps can be supplied with custom pad printing.

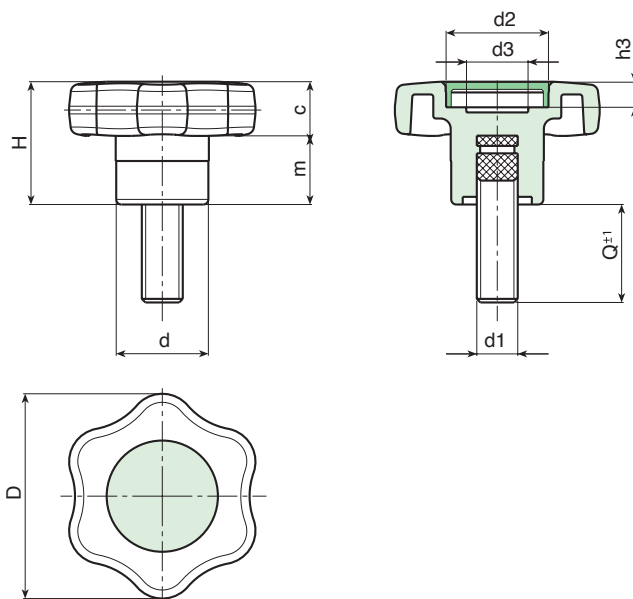

Code	art.	D	H	d	m	c	d2	d3	h3	d1 <sub>6g</sub>	Q	g
G65140.0002	G65140.TM06X2001	40	24	18	10.5	13.5	20	13	6	M6	20	-
G65140.0014	G65140.TM08X3001	40	24	18	10.5	13.5	20	13	6	M8	30	24
G65140.0020	G65140.TM10X3001	40	24	18	10.5	13.5	20	13	6	M10	30	-

Customised stud length available for a minimum of 100 pieces.





# G730

## 4-LOBE HANDWHEEL WITH THREADED INSERT



### Materials:

Reinforced polyamide. Resistant to oils and greases.

### Surface finish:

Satin.

### Colour:

Black (RAL 9011).

### Inserts:

Brass insert with female threaded hole (thread tolerance 6H).

(\*) Galvanised steel insert with female threaded hole (thread tolerance 6H).

### Special requests:

- Upon request and for special quantities inserts can be supplied in different materials.
- Upon request and for special quantities available in the colours indicated in the chart [page 959].

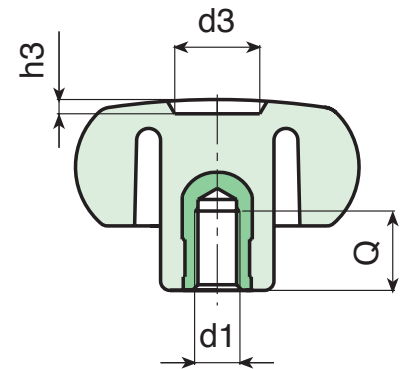
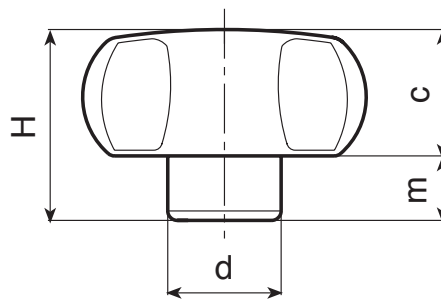
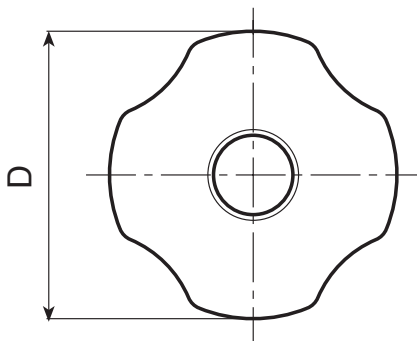

Code	art.	D	H	d	c	m	d3	h3	d1 <sub>6H</sub>	Q	g
G73020.0002	G73020.TM0401	21	14	11	8.5	5.5	8	1.5	M4	6	5
G73020.0004	G73020.TM0501	21	14	11	8.5	5.5	8	1.5	M5	6	5
G73020.0006	G73020.TM0601	21	14	11	8.5	5.5	8	1.5	M6	6	5
G73025.0001	G73025.TM0401	26	16	12	10	6	10	1.5	M8	7	6
G73025.0002	G73025.TM0501	26	16	12	10	6	10	1.5	M5	7	6
G73025.0007	G73025.TM0601	26	16	12	10	6	10	1.5	M6	7	7
G73025.0010	G73025.TM0801	26	16	12	10	6	10	1.5	M8	7	8
G73030.0001	G73030.TM0501	30	23	15	13.5	9.5	12	2	M5	13	12
G73030.0004	G73030.TM0601	30	23	15	13.5	9.5	12	2	M6	10	12
G73030.0008	G73030.TM0801	30	23	15	13.5	9.5	12	2	M8	16	14
G73030.0012	G73030.TM1001	30	23	15	13.5	9.5	12	2	M10	16	14
G73040.0005	G73040.TM0501	40.5	29.5	17	18.5	11	12	3	M5	13	21
G73040.0009	G73040.TM0601	40.5	29.5	17	18.5	11	12	3	M6	10	21
G73040.0014	G73040.TM0801	40.5	29.5	17	18.5	11	12	3	M8	14	22
G73040.0023	G73040.TM1001	40.5	29.5	17	18.5	11	12	3	M10	13	26
G73040.0029	G73040.TM1201	40.5	29.5	17	18.5	11	12	3	M12	11	30
G73050.0003	G73050.TM0601	49	32	20.5	21.5	11	14.5	2.5	M6	10	35
G73050.0004	G73050.TM0801	49	32	20.5	21.5	11	14.5	2.5	M8	14	42
G73050.0008	G73050.TM1001	49	32	20.5	21.5	11	14.5	2.5	M10	13	43
G73050.0011	G73050.TM1201	49	32	20.5	21.5	11	14.5	2.5	M12	17	48
G73060.0003	G73060.TM0801	59	40	23	25	15	24	4	M8	15	60
G73060.0006	G73060.TM1001	59	40	23	25	15	24	4	M10	14	62
G73060.0012	G73060.TM1201	59	40	23	25	15	24	4	M12	18	67
G73060.0016	G73060.TM1401	59	40	23	25	15	24	4	M14	19	70
G73060.0018	G73060.TM1601	59	40	23	25	15	24	4	(*)M16	17	82
G73080.0013	G73080.TM1001	79	41	30	24	17	21	3	M10	14	88
G73080.0015	G73080.TM1201	79	41	30	24	17	21	3	M12	16	88
G73080.0018	G73080.TM1401	79	41	30	24	17	21	3	M14	19	97
G73080.0019	G73080.TM1601	79	41	30	24	17	21	3	(*)M16	17	109
G73080.0023	G73080.TM2001	79	41	30	24	17	21	3	(*)M20	16	115

# G732

## 4-LOBE HANDWHEEL WITH THREADED STUD



### Materials:

Reinforced polyamide. Resistant to oils and greases.

### Surface finish:

Satin.

### Colour:

Black (RAL 9011).

### Inserts:

Galvanised steel threaded stud (thread tolerance 6g).

### Special requests:

- Upon request and for special quantities inserts can be supplied with customised lengths.
- Upon request and for special quantities inserts can be supplied in different materials.
- Upon request and for special quantities available in the colours indicated in the chart [page 959].

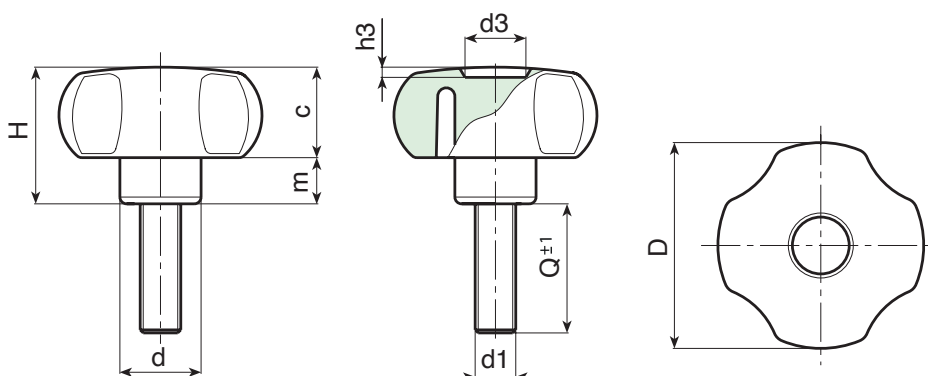

Code	art.	D	H	d	c	m	d3	h3	LM	d1 <sub>6g</sub>	Q	g
G73220.0006	G73220.TM04X1001	21	14	11	8,5	5,5	8	1,5	50	M4	10	4
G73220.0009	G73220.TM04X1601	21	14	11	8,5	5,5	8	1,5	50	M4	16	4,5
G73220.0010	G73220.TM04X2001	21	14	11	8,5	5,5	8	1,5	50	M4	20	5
G73220.0016	G73220.TM05X1001	21	14	11	8,5	5,5	8	1,5	50	M5	10	6
G73220.0019	G73220.TM05X1601	21	14	11	8,5	5,5	8	1,5	50	M5	16	6,5
G73220.0020	G73220.TM05X2001	21	14	11	8,5	5,5	8	1,5	50	M5	20	7
G73220.0024	G73220.TM05X3001	21	14	11	8,5	5,5	8	1,5	50	M5	30	8
G73220.0033	G73220.TM06X1001	21	14	11	8,5	5,5	8	1,5	50	M6	10	6,5
G73220.0037	G73220.TM06X1601	21	14	11	8,5	5,5	8	1,5	50	M6	16	7,5
G73220.0039	G73220.TM06X2001	21	14	11	8,5	5,5	8	1,5	50	M6	20	8
G73220.0041	G73220.TM06X3001	21	14	11	8,5	5,5	8	1,5	50	M6	30	9,5
G73220.0043	G73220.TM06X4001	21	14	11	8,5	5,5	8	1,5	50	M6	40	11
G73225.0014	G73225.TM05X1001	26	16	12	10	6	10	1,5	95	M5	10	8
G73225.0016	G73225.TM05X1601	26	16	12	10	6	10	1,5	95	M5	16	8,5
G73225.0017	G73225.TM05X2001	26	16	12	10	6	10	1,5	95	M5	20	9
G73225.0019	G73225.TM05X2501	26	16	12	10	6	10	1,5	95	M5	25	9,5
G73225.0030	G73225.TM06X1001	26	16	12	10	6	10	1,5	95	M6	10	10
G73225.0035	G73225.TM06X1601	26	16	12	10	6	10	1,5	95	M6	16	11
G73225.0038	G73225.TM06X2001	26	16	12	10	6	10	1,5	95	M6	20	13
G73225.0043	G73225.TM06X2501	26	16	12	10	6	10	1,5	95	M6	25	14
G73225.0044	G73225.TM06X3001	26	16	12	10	6	10	1,5	95	M6	30	15
G73225.0056	G73225.TM08X1601	26	16	12	10	6	10	1,5	90	M8	16	14
G73225.0058	G73225.TM08X2001	26	16	12	10	6	10	1,5	90	M8	20	16
G73225.0063	G73225.TM08X3001	26	16	12	10	6	10	1,5	90	M8	30	20

# G732

## 4-LOBE HANDWHEEL WITH THREADED STUD

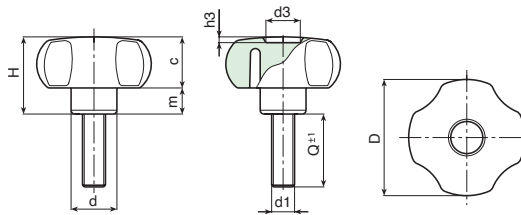

Code	art.	D	H	d	c	m	d3	h3	LM	d1 <sub>6g</sub>	Q	g
G73225.0066	G73225.TM08X4001	26	16	12	10	6	10	1.5	90	M8	40	24
G73230.0008	G73230.TM05X2001	30	23	15	13.5	9.5	12	2	90	M5	20	13
G73230.0010	G73230.TM05X3001	30	23	15	13.5	9.5	12	2	90	M5	30	14
G73230.0018	G73230.TM06X1001	30	23	15	13.5	9.5	12	2	90	M6	10	14
G73230.0024	G73230.TM06X1601	30	23	15	13.5	9.5	12	2	90	M6	16	15
G73230.0025	G73230.TM06X2001	30	23	15	13.5	9.5	12	2	90	M6	20	16
G73230.0038	G73230.TM06X3001	30	23	15	13.5	9.5	12	2	90	M6	30	18
G73230.0047	G73230.TM06X4001	30	23	15	13.5	9.5	12	2	90	M6	40	20
G73230.0051	G73230.TM06X5001	30	23	15	13.5	9.5	12	2	90	M6	50	22
G73230.0066	G73230.TM08X1601	30	23	15	13.5	9.5	12	2	90	M8	16	20
G73230.0068	G73230.TM08X2001	30	23	15	13.5	9.5	12	2	90	M8	20	22
G73230.0078	G73230.TM08X3001	30	23	15	13.5	9.5	12	2	90	M8	30	25
G73230.0086	G73230.TM08X4001	30	23	15	13.5	9.5	12	2	90	M8	40	28
G73230.0093	G73230.TM08X5001	30	23	15	13.5	9.5	12	2	90	M8	50	31
G73230.0106	G73230.TM10X2001	30	23	15	13.5	9.5	12	2	90	M10	20	25
G73230.0114	G73230.TM10X5001	30	23	15	13.5	9.5	12	2	90	M10	50	43
G73240.0011	G73240.TM06X1001	40.5	29.5	15.5	18.5	11	12	3	100	M6	10	23
G73240.0013	G73240.TM06X1601	40.5	29.5	15.5	18.5	11	12	3	100	M6	16	24
G73240.0015	G73240.TM06X2001	40.5	29.5	15.5	18.5	11	12	3	100	M6	20	26
G73240.0022	G73240.TM06X3001	40.5	29.5	15.5	18.5	11	12	3	100	M6	30	28
G73240.0027	G73240.TM06X4001	40.5	29.5	15.5	18.5	11	12	3	100	M6	40	30
G73240.0057	G73240.TM08X1601	40.5	29.5	15	18.5	11	12	3	100	M8	16	28
G73240.0061	G73240.TM08X2001	40.5	29.5	15	18.5	11	12	3	100	M8	20	31
G73240.0082	G73240.TM08X3001	40.5	29.5	15	18.5	11	12	3	100	M8	30	34
G73240.0094	G73240.TM08X4001	40.5	29.5	15	18.5	11	12	3	100	M8	40	37
G73240.0102	G73240.TM08X5001	40.5	29.5	15	18.5	11	12	3	100	M8	50	40
G73240.0159	G73240.TM10X2001	40.5	29.5	17.5	18.5	11	12	3	100	M10	20	38
G73240.0168	G73240.TM10X3001	40.5	29.5	17.5	18.5	11	12	3	100	M10	30	43
G73250.0009	G73250.TM06X2001	49	32	20.5	21.5	11	14.5	2.5	120	M6	20	43
G73250.0024	G73250.TM08X1601	49	32	20.5	21.5	11	14.5	2.5	120	M8	16	49
G73250.0025	G73250.TM08X2001	49	32	20.5	21.5	11	14.5	2.5	120	M8	20	51
G73250.0036	G73250.TM08X3001	49	32	20.5	21.5	11	14.5	2.5	120	M8	30	54
G73250.0043	G73250.TM08X4001	49	32	20.5	21.5	11	14.5	2.5	120	M8	40	57
G73250.0047	G73250.TM08X5001	49	32	20.5	21.5	11	14.5	2.5	120	M8	50	60
G73250.0051	G73250.TM08X6001	49	32	20.5	21.5	11	14.5	2.5	120	M8	60	64
G73250.0089	G73250.TM10X2001	49	32	20.5	21.5	11	14.5	2.5	120	M10	20	58
G73250.0103	G73250.TM10X3001	49	32	20.5	21.5	11	14.5	2.5	120	M10	30	63
G73250.0113	G73250.TM10X4001	49	32	20.5	21.5	11	14.5	2.5	120	M10	40	68
G73250.0120	G73250.TM10X5001	49	32	20.5	21.5	11	14.5	2.5	120	M10	50	72
G73250.0125	G73250.TM10X6001	49	32	20.5	21.5	11	14.5	2.5	120	M10	60	77
G73250.0147	G73250.TM12X3001	49	32	20.5	21.5	11	14.5	2.5	120	M12	30	77
G73250.0152	G73250.TM12X5001	49	32	20.5	21.5	11	14.5	2.5	120	M12	50	90
G73260.0003	G73260.TM08X1601	59	40	23	25	15	24	4	120	M8	16	81
G73260.0004	G73260.TM08X2001	59	40	23	25	15	24	4	120	M8	20	81
G73260.0008	G73260.TM08X3001	59	40	23	25	15	24	4	120	M8	30	81
G73260.0010	G73260.TM08X4001	59	40	23	25	15	24	4	120	M8	40	81
G73260.0012	G73260.TM08X5001	59	40	23	25	15	24	4	120	M8	50	81
G73260.0029	G73260.TM10X2001	59	40	23	25	15	24	4	120	M10	20	79
G73260.0034	G73260.TM10X3001	59	40	23	25	15	24	4	120	M10	30	84
G73260.0049	G73260.TM10X6001	59	40	23	25	15	24	4	120	M10	60	100
G73260.0068	G73260.TM12X2501	59	40	23	25	15	24	4	120	M12	25	94
G73260.0071	G73260.TM12X3001	59	40	23	25	15	24	4	120	M12	30	97
G73260.0076	G73260.TM12X4001	59	40	23	25	15	24	4	120	M12	40	104
G73260.0080	G73260.TM12X5001	59	40	23	25	15	24	4	120	M12	50	111
G73260.0085	G73260.TM12X6001	59	40	23	25	15	24	4	120	M12	60	119
G73280.0036	G73280.TM12X2501	79	41	30	24	17	21	3	80	M12	25	115
G73280.0045	G73280.TM12X5001	79	41	30	24	17	21	3	80	M12	50	135
G73280.0046	G73280.TM12X6001	79	41	30	24	17	21	3	80	M12	60	142

LM = Maximum mouldable length.  
Customised stud length available for a minimum of 100 pieces.



# G731

## 4-LOBE HANDWHEEL WITH THREADED THROUGH INSERT



### Materials:

Reinforced polyamide. Resistant to oils and greases.

### Surface finish:

Satin.

### Colour:

Black (RAL 9011).

### Inserts:

Brass insert with threaded through hole (thread tolerance 6H).

(\*) Galvanised steel insert with threaded through hole (thread tolerance 6H).

### Special requests:

- Upon request and for special quantities inserts can be supplied in different materials.
- Upon request and for special quantities available in the colours indicated in the chart [page 959].

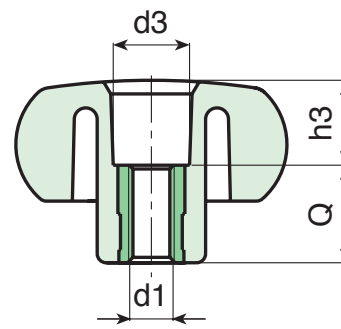
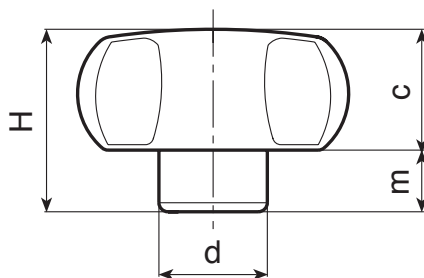
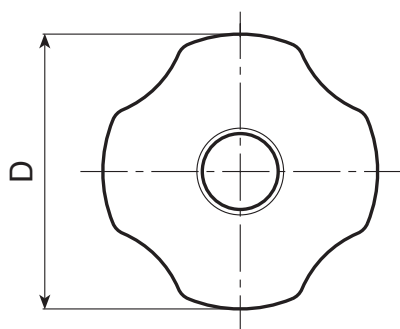

Code	art.	D	H	d	c	m	d3	h3	d1 <sub>6H</sub>	Q	g
G73120.0001	G73120.TM0401	21	14	11	8.5	5.5	8	4.5	M4	9.5	4
G73120.0002	G73120.TM0501	21	14	11	8.5	5.5	8	7.5	M5	6.5	5
G73120.0003	G73120.TM0601	21	14	11	8.5	5.5	8	7.5	M6	6.5	5
G73125.0002	G73125.TM0401	26	16	12	10	6	9	7.5	M8	8.5	5
G73125.0003	G73125.TM0501	26	16	12	10	6	9	9.5	M5	6.5	6
G73125.0005	G73125.TM0601	26	16	12	10	6	9	9.5	M6	6.5	6
G73125.0006	G73125.TM0801	26	16	12	10	6	10.5	1.5	M8	14.5	10
G73130.0001	G73130.TM0501	30	23	15	13.5	9.5	12	8.5	M5	14.5	11
G73130.0002	G73130.TM0601	30	23	15	13.5	9.5	12	8.5	M6	14.5	11
G73130.0005	G73130.TM0801	30	23	15	13.5	9.5	12	8.5	M8	14.5	12
G73130.0007	G73130.TM1001	30	23	15	13.5	9.5	12	8.5	M10	14.5	13
G73140.0010	G73140.TM0601	40.5	29.5	15.5	18.5	11	13	11.5	M6	18	21
G73140.0014	G73140.TM0801	40.5	29.5	15	18.5	11	13	11.5	M8	18	21
G73140.0022	G73140.TM1001	40.5	29.5	17.5	18.5	11	13	11.5	M10	18	23
G73140.0025	G73140.TM1201	40.5	29.5	21	18.5	11	13	11.5	M12	18	26
G73150.0002	G73150.TM0601	49	32	20.5	21.5	11	13.5	14.5	M6	18	37
G73150.0003	G73150.TM0801	49	32	20.5	21.5	11	13.5	14.5	M8	18	38
G73150.0004	G73150.TM1001	49	32	20.5	21.5	11	13.5	14.5	M10	18	39
G73150.0008	G73150.TM1201	49	32	20.5	21.5	11	13.5	14.5	M12	18	40
G73160.0001	G73160.TM0801	59	40	23	25	15	20	22	M8	18	54
G73160.0004	G73160.TM1001	59	40	23	25	15	20	22	M10	18	55
G73160.0006	G73160.TM1201	59	40	23	25	15	20	22	M12	18	55
G73160.0008	G73160.TM1401	59	40	23	25	15	20	22	M14	18	56
G73180.0004	G73180.TM1001	79	41	30	24	17	20	23	M10	18	82
G73180.0006	G73180.TM1201	79	41	30	24	17	20	23	M12	18	79
G73180.0007	G73180.TM1401	79	41	30	24	17	20	23	M14	18	80
G73180.0008	G73180.TM1601	79	41	30	24	17	21	15	(*)M16	26	102

# G733



## 4-LOBE HANDWHEEL WITH SMOOTH HOLE INSERT

### Materials:

Reinforced polyamide.  
Resistant to oils and greases.

### Surface finish:

Satin.

### Colour:

Black (RAL 9011).

### Inserts:

(\*) Brass insert with smooth blind hole (hole tolerance H7).

ATTENTION: hole cannot be widened.

(#) Galvanised steel insert with blind smooth hole (hole tolerance H10).

### Special requests:

- Upon request and for special quantities inserts can be supplied in different materials.
- Upon request and for special quantities available in the colours indicated in the chart [page 959].



07

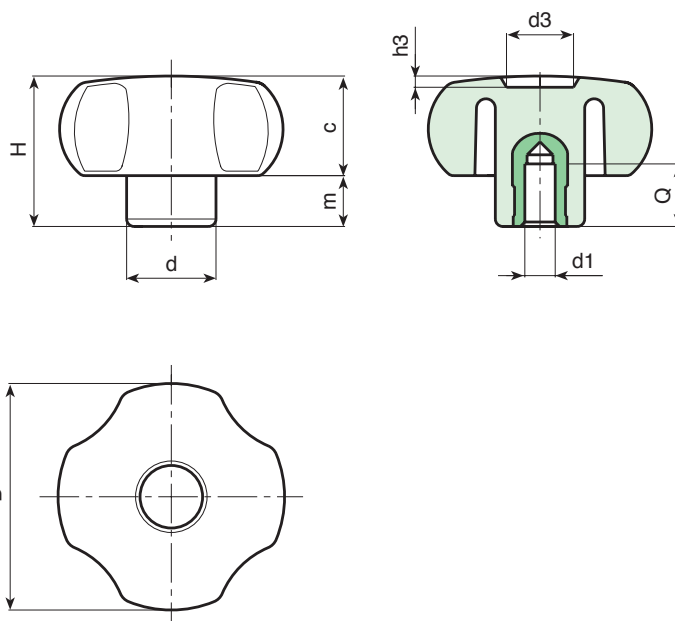

Code	art.	D	H	d	c	m	d3	h3	Dm	d1H7	Q	g
G73330.0002	G73330.TD0601	30	23	15	13,5	9,5	12	2	-	(*)06	15	16
G73330.0005	G73330.TD0801	30	23	15	13,5	9,5	12	2	-	(*)08	15	17
G73340.0004	G73340.TD0601	40,5	29,5	15,5	18,5	11	12	3	-	(*)06	15	24
G73340.0005	G73340.TD0801	40,5	29,5	15	18,5	11	12	3	-	(*)08	15	28
G73340.0006	G73340.TD1001	40,5	29,5	17	18,5	11	12	3	-	(*)10	15	30
G73350.0001	G73350.TD0601	49	32	20,5	21,5	11	14,5	2,5	12	(#)06	18	60
G73350.0002	G73350.TD0801	49	32	20,5	21,5	11	14,5	2,5	12	(#)08	18	62
G73350.0003	G73350.TD1001	49	32	20,5	21,5	11	14,5	2,5	12	(#)10	18	63
G73360.0016	G73360.TP0501	60	40,5	23	25	15,5	25	4	12	(#)05	18	90
G73360.0002	G73360.TD0801	60	40,5	23	25	15,5	25	4	12	(#)08	18	93
G73360.0004	G73360.TD1001	60	40,5	23	25	15,5	25	4	12	(#)10	18	96
G73380.0025	G73380.TP0501	79	41	30	24	17	21	3	18	(#)05	24	165
G73380.0007	G73380.TD0801	79	41	30	24	17	21	3	18	(#)08	24	159
G73380.0012	G73380.TD1201	79	41	30	24	17	21	3	18	(#)12	24	153

Attention: (#) for a minimum of 200 pieces the diameter d1 can be produced with the requested dimensions with H10 tolerance.  
Dm = Maximum obtainable diameter for subsequent machining (widening)



# G734



## 4-LOBE HANDWHEEL WITH ELONGATED HUB AND THREADED INSERT

### Materials:

Reinforced polyamide. Resistant to oils and greases.

### Surface finish:

Satin.

### Colour:

Black (RAL 9011).

### Inserts:

Brass insert with female threaded hole (thread tolerance 6H).

### Special requests:

- Upon request and for special quantities inserts can be supplied in different materials.
- Upon request and for special quantities handwheels can be supplied with custom hubs.

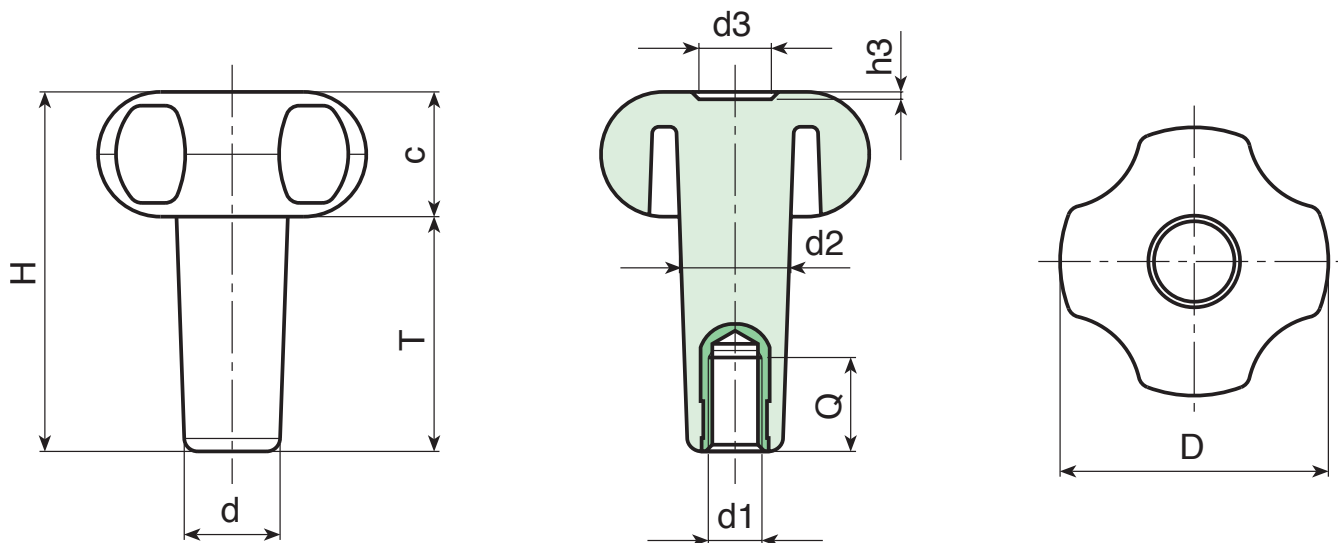

Code	art.	D	H	T	d	c	d2	d3	h3	d1 <sub>6H</sub>	Q	g
G73430.0004	G73430.T25M0601	30	37.5	23.5	13.5	14	14.5	12	2	M6	10	15
G73430.0007	G73430.T35M0601	30	47	33.5	13.5	14	15	12	2	M6	16	16
G73430.0008	G73430.T35M0801	30	47	33.5	13.5	14	15	12	2	M8	21	17
G73440.0006	G73440.T35M1001	41	54	35	16.5	19	17	12	3	M10	15	30
G73440.0007	G73440.T66M0601	41	85	66	16.5	19	18	12	3	M6	18	35
G73450.0009	G73450.T40M0801	52	61	39	17.5	22	19	14	2.5	M8	15	47
G73450.0010	G73450.T40M1001	52	61	39	17.5	22	19	14	2.5	M10	15	49
G73450.0011	G73450.T50M0801	52	71	49	18	22	20.5	14	2.5	M8	15	55
G73450.0013	G73450.T50M1001	52	71	49	18	22	20.5	14	2.5	M10	15	56
G73450.0016	G73450.T60M1001	52	80	58	18	22	21	14	2.5	M10	15	62
G73460.0006	G73460.T60M0801	59	83	58	23	25	24	24	4	M8	21	91
G73460.0007	G73460.T60M1001	59	83	58	23	25	24	24	4	M10	15	91
G73460.0008	G73460.T60M1201	59	83	58	23	25	24	24	4	M12	21	96
G73460.0011	G73460.T80M0801	59	103	78	23	25	24	24	4	M8	21	105
G73460.0012	G73460.T80M1001	59	103	78	23	25	24	24	4	M10	15	104
G73460.0014	G73460.T80M1201	59	103	78	23	25	24	24	4	M12	21	107

# G735



## 4-LOBE HANDWHEEL WITH ELONGATED HUB AND THREADED STUD

### Materials:

Reinforced polyamide. Resistant to oils and greases.

### Surface finish:

Satin.

### Colour:

Black (RAL 9011).

### Inserts:

Galvanised steel threaded stud (thread tolerance 6g).

### Special requests:

- Upon request and for special quantities inserts can be supplied with customised lengths.
- Upon request and for special quantities inserts can be supplied in different materials.
- Upon request and for special quantities handwheels can be supplied with custom hubs.



07

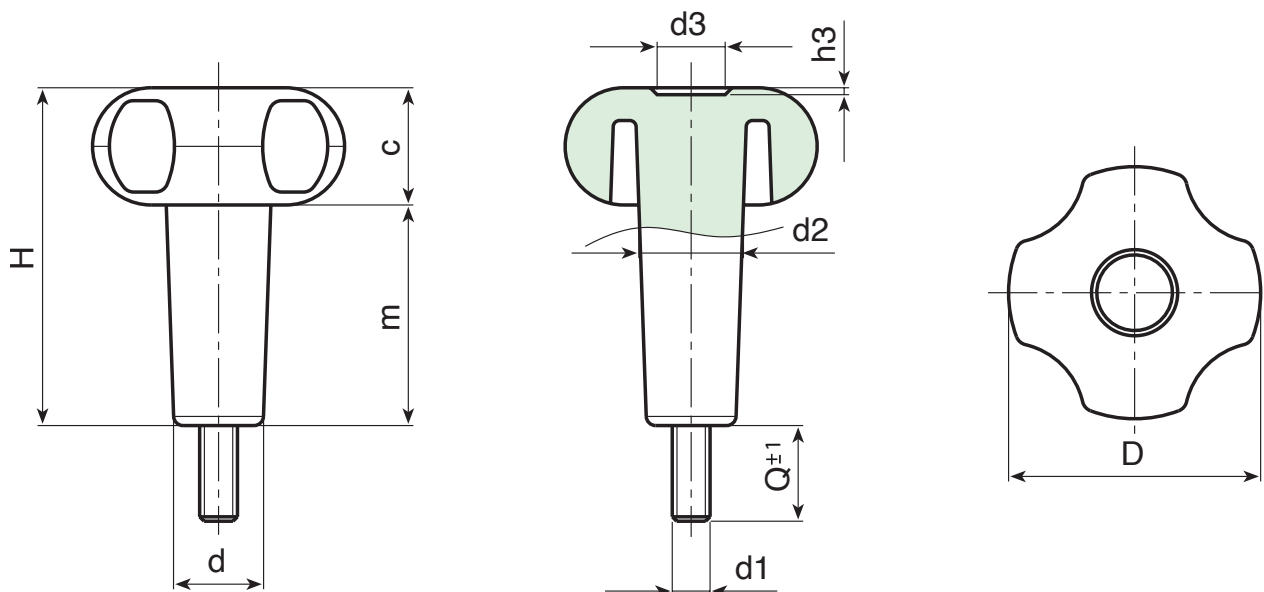

Code	art.	D	H	m	d	c	d2	d3	h3	LM	d1 <sub>6g</sub>	Q	
G73530.0008	G73530.T35M06X1501	30	47	33.5	13.5	14	15	12	2	65	M6	15	23
G73530.0013	G73530.T35M08X3001	30	47	33.5	13.5	14	15	12	2	65	M8	30	36
G73540.0003	G73540.T35M08X2001	41	54	35	16.5	19	17	12	3	80	M8	20	49
G73540.0013	G73540.T35M10X1501	41	54	35	16.5	19	17	12	3	80	M10	15	54
G73550.0009	G73550.T40M08X1501	52	61	39	17.5	22	19	14	2.5	90	M8	15	60
G73550.0028	G73550.T40M10X4001	52	61	39	17.5	22	19	14	2.5	90	M10	40	82
G73550.0047	G73550.T60M08X3001	52	80	58	18	22	21	14	2.5	70	M8	30	86
G73560.0018	G73560.T60M10X4001	59	83	58	23	25	24	24	4	75	M10	40	138

LM = Maximum mouldable length.

Customised stud length available for a minimum of 100 pieces.



# G745

# G746



## 4-LOBE HANDWHEEL WITH CAP WITH THREADED INSERT, BLIND AND THROUGH

### Materials:

Reinforced polyamide. Resistant to oils and greases.

### Surface finish:

Satin.

### Colour:

Black (RAL 9011).

### Central cap:

Grey polyamide (RAL 7035). 13).

### Alternative cap colours:

Orange (RAL 2004 code 02).  
 Blue (RAL 5015 code 07).  
 Yellow (RAL 1021 code 10).  
 Green (RAL 6024 code 17).  
 Red (RAL 3000 code 16).  
 Black (RAL 9011 code 01).

### Inserts:

G745: Brass insert with female threaded hole (thread tolerance 6H).

G746: Brass right through threaded bush (tolerance 6H).

### Special requests:

- Upon request and for special quantities inserts can be supplied in different materials.
- Upon request and for special quantities available in the colours indicated in the chart on page 959.

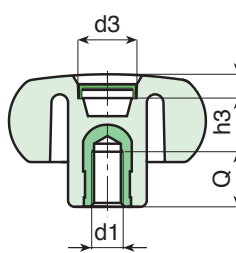
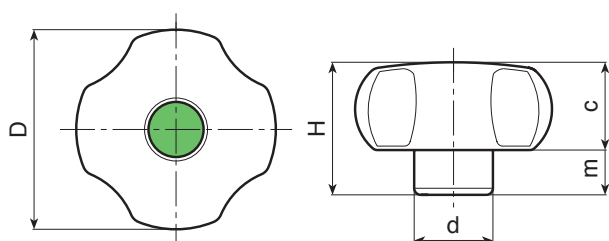

G745

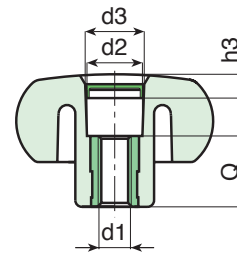

G746

### Version G745: with blind insert

Code	art.	D	H	d	c	m	d3	h3	d1 <sub>6H</sub>	Q	g
G74540.0001	G74540.TM0501	40.5	29.5	17	18.5	11	20	7.5	M5	13	18
G74540.0002	G74540.TM0601	40.5	29.5	17	18.5	11	20	7.5	M6	10	18
G74540.0004	G74540.TM0801	40.5	29.5	17	18.5	11	20	7.5	M8	14	19
G74540.0005	G74540.TM1001	40.5	29.5	17	18.5	11	20	7.5	M10	13	23
G74540.0006	G74540.TM1201	40.5	29.5	17	18.5	11	20	7.5	M12	11	27
G74550.0001	G74550.TM0601	49	32	20.5	21.5	11	20	7.5	M6	10	32
G74550.0002	G74550.TM0801	49	32	20.5	21.5	11	20	7.5	M8	14	39
G74550.0006	G74550.TM1001	49	32	20.5	21.5	11	20	7.5	M10	13	40
G74550.0007	G74550.TM1201	49	32	20.5	21.5	11	20	7.5	M12	17	44
G74560.0001	G74560.TM0801	59	40	23	25	15	22	7.5	M8	15	55
G74560.0003	G74560.TM1001	59	40	23	25	15	22	7.5	M10	14	57
G74560.0004	G74560.TM1201	59	40	23	25	15	22	7.5	M12	18	62
G74560.0011	G74560.TM1401	59	40	23	25	15	22	7.5	M14	19	65

### Version G746: with through insert

Code	art.	D	H	d	c	m	d3	h3	d1 <sub>6H</sub>	Q	g
G74640.0001	G74640.TM0501	40.5	29.5	17	18.5	11	20	7.5	M5	18	17
G74640.0003	G74640.TM0601	40.5	29.5	17	18.5	11	20	7.5	M6	18	17
G74640.0007	G74640.TM0801	40.5	29.5	17	18.5	11	20	7.5	M8	18	18
G74640.0011	G74640.TM1001	40.5	29.5	17	18.5	11	20	7.5	M10	18	22
G74640.0012	G74640.TM1201	40.5	29.5	17	18.5	11	20	7.5	M12	18	26
G74650.0002	G74650.TM0601	49	32	20.5	21.5	11	20	7.5	M6	18	31
G74650.0003	G74650.TM0801	49	32	20.5	21.5	11	20	7.5	M8	18	38
G74650.0005	G74650.TM1001	49	32	20.5	21.5	11	20	7.5	M10	18	39
G74650.0006	G74650.TM1201	49	32	20.5	21.5	11	20	7.5	M12	18	43
G74660.0001	G74660.TM0801	59	40	23	25	15	22	7.5	M8	18	54
-	G74660.TM1001	59	40	23	25	15	22	7.5	M10	18	56
G74660.0003	G74660.TM1201	59	40	23	25	15	22	7.5	M12	18	61
G74660.0004	G74660.TM1401	59	40	23	25	15	22	7.5	M14	18	64



## 4-LOBE HANDWHEEL WITH CAP AND THREADED STUD

**Materials:**

Reinforced polyamide. Resistant to oils and greases.

**Surface finish:**

Satin.

**Colour:**

Black (RAL 9011).

**Central cap:**

Grey polyamide (RAL 7035). 13).

**Alternative cap colours:**

Orange (RAL 2004 code 02).  
 Blue (RAL 5015 code 07).  
 Yellow (RAL 1021 code 10).  
 Green (RAL 6024 code 17).  
 Red (RAL 3000 code 16).  
 Black (RAL 9011 code 01).

**Inserts:**

Galvanised steel threaded stud (thread tolerance 6g).

**Special requests:**

- Upon request and for special quantities inserts can be supplied with customised lengths.
- Upon request and for special quantities inserts can be supplied in different materials.
- Upon request and for special quantities available in the colours indicated in the chart [page 959].



07

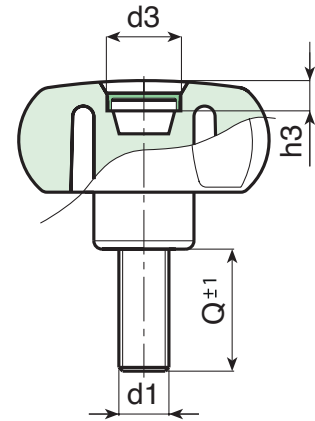
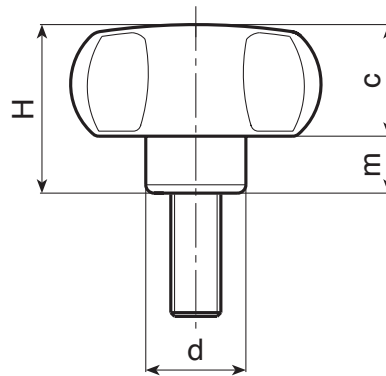
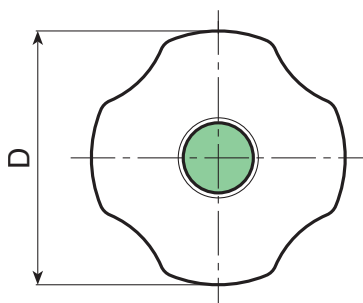

Code	art.	D	H	d	c	m	d3	h3	LM	d1 <sub>6H</sub>	Q	
G74740.0003	G74740.TM06X3001	40.5	29.5	15.5	18.5	11	20	7.5	100	M6	30	-
G74740.0016	G74740.TM08X2001	40.5	29.5	15	18.5	11	20	7.5	100	M8	20	-
G74760.0003	G74760.TM08X3001	59	40	23	25	15	22	7.5	120	M8	30	-
G74760.0005	G74760.TM10X3001	59	40	23	25	15	22	7.5	120	M10	30	-
G74760.0015	G74760.TM12X3001	59	40	23	25	15	22	7.5	120	M12	30	-

LM = Maximum mouldable length.

A.R. = Customised stud length available for a minimum of 150 pieces.

# G791

## CYLINDRICAL HANDWHEEL WITH THREADED INSERT

+135°  
-30°

PA6  
+G.F.

UL94  
HB

RoHS  
COMPLIANT

### Materials:

Reinforced polyamide. Resistant to oils and greases.

### Surface finish:

Satin.

### Colour:

Black (RAL 9011).

### Inserts:

Brass insert with female threaded hole (thread tolerance 6H).

### Special requests:

- Upon request and for special quantities inserts can be supplied in different materials.
- Upon request and for special quantities available in the colours indicated in the chart [page 959].

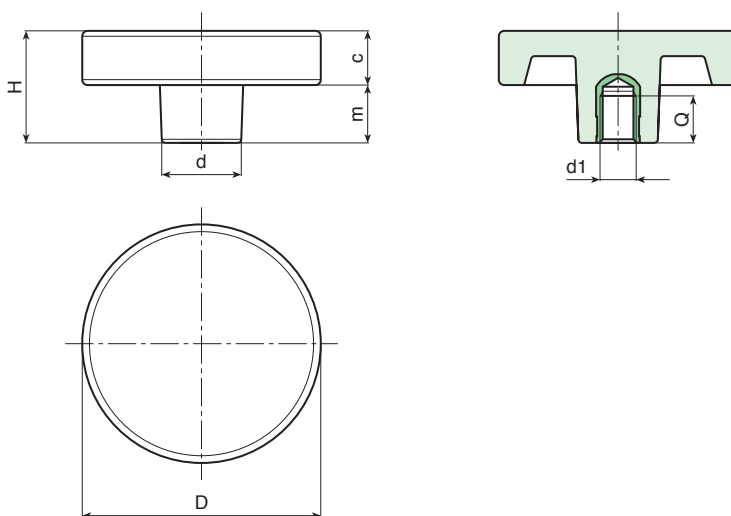

Code	art.	D	H	d	c	m	d1 <sub>6H</sub>	Q	g
G79136.0004	G79136.TM0601	36	17,5	18	16	1,5	M6	10	18
G79136.0006	G79136.TM0801	36	17,5	18	16	1,5	M8	15	18
G79136.0008	G79136.TM1001	36	17,5	18	16	1,5	M10	14	19
G79150.0003	G79150.TM0801	50	30	22	15	15	M8	15	35
G79150.0005	G79150.TM1001	50	30	22	15	15	M10	14	36
G79150.0007	G79150.TM1201	50	30	22	15	15	M12	18	40
G79166.0001	G79166.TM0801	66	30	22	15	15	M8	15	52
G79166.0002	G79166.TM1001	66	30	22	15	15	M10	14	55
G79166.0004	G79166.TM1201	66	30	22	15	15	M12	18	58
G79166.0006	G79166.TM1401	66	30	22	15	15	M14	19	60

# G792

## CYLINDRICAL HANDWHEEL WITH SMOOTH HOLE INSERT



**Materials:**

Reinforced polyamide.  
Resistant to oils and greases.

**Surface finish:**

Satin.

**Colour:**

Black (RAL 9011).

**Inserts:**

Galvanised steel insert with smooth through bore (tolerance H10).

**Special requests:**

- Upon request and for special quantities inserts can be supplied with custom hole diameter d1.
- Upon request and for special quantities inserts can be supplied in different materials/with different coatings.
- Upon request and for special quantities available in the colours indicated in the chart [page 959].



07

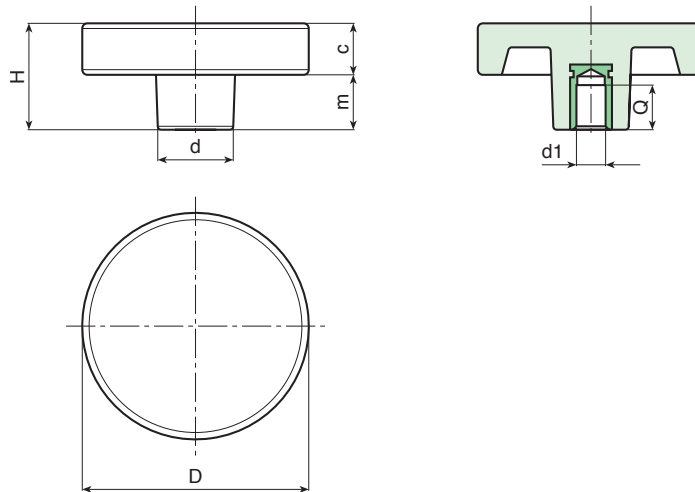

Code	art.	D	H	d	c	m	Dm	d1 <sub>H10</sub>	Q	
G79250.0001	G79250.TD0601	50	30	22	15	15	12	06	20	62
G79266.0001	G79266.TD1001	65	30	22	15	15	12	10	20	78

Attention: for a minimum of 200 pieces the diameter d1 can be produced with the requested dimensions with H10 tolerance.  
Dm = Maximum obtainable diameter for subsequent machining (widening)



# G793

## CYLINDRICAL HANDWHEEL WITH THREADED STUD



### Materials:

Reinforced polyamide.  
Resistant to oils and greases.

### Surface finish:

Satin.

### Colour:

Black (RAL 9011).

### Inserts:

Galvanised steel threaded stud (thread tolerance 6g).

### Special requests:

- Upon request and for special quantities inserts can be supplied with customised lengths.
- Upon request and for special quantities inserts can be supplied in different materials.
- Upon request and for special quantities available in the colours indicated in the chart [page 959].

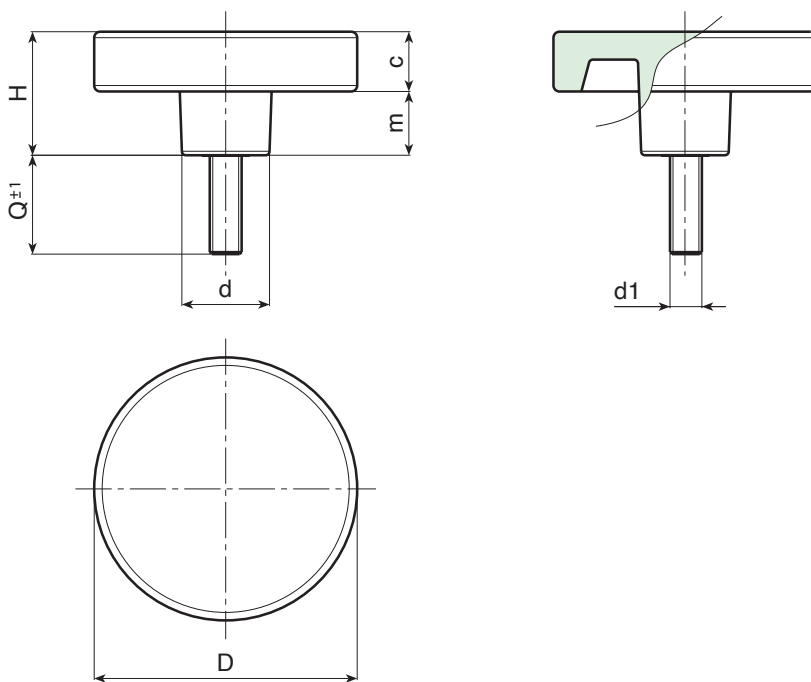

Code	art.	D	H	d	c	m	LM	d1 <sub>6g</sub>	Q	
G79336.0010	G79336.TM06X3001	36	17,5	18	16	1,5	50	M6	30	20
G79336.0027	G79336.TM08X3001	36	17,5	18	16	1,5	50	M8	30	27
G79336.0051	G79336.TM10X4001	36	17,5	18	16	1,5	50	M10	40	42
G79350.0010	G79350.TM08X2501	50	30	22	15	15	60	M8	25	44
G79350.0016	G79350.TM10X2501	50	30	22	15	15	60	M10	25	51
G79350.0024	G79350.TM12X3001	50	30	22	15	15	60	M12	30	80
G79366.0004	G79366.TM08X1501	65	30	22	15	15	60	M8	15	58
G79366.0008	G79366.TM10X5001	65	30	22	15	15	60	M10	50	80
G79366.0011	G79366.TM12X2501	65	30	22	15	15	60	M12	25	97

LM = Maximum mouldable length.  
Customised stud lengths available for a minimum of 150 pieces.



# G794

## KNOB WITH THREADED INSERT



### Materials:

Reinforced polyamide.  
Resistant to oils and greases.

### Surface finish:

Satin.

### Colour:

Black (RAL 9011).

### Inserts:

Brass insert with female threaded hole (thread tolerance 6H).

### Special requests:

- Upon request and for special quantities inserts can be supplied in different materials.
- Upon request and for special quantities available in the colours indicated in the chart [page 959].



07

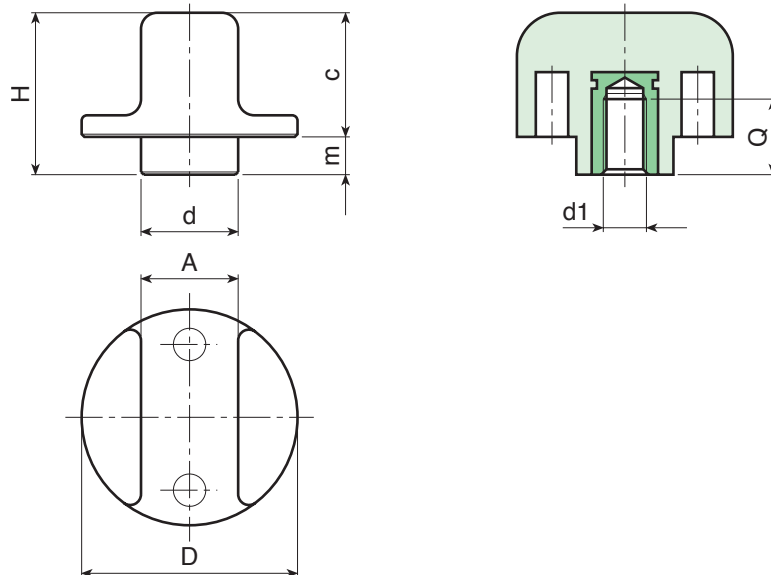

Code	art.	D	H	d	A	c	m	d <sub>16H</sub>	Q	g
G79425.0001	G79425.TM0501	25	20	12	10	15	5	M5	11	8
G79425.0003	G79425.TM0601	25	20	12	10	15	5	M6	9	9
G79425.0005	G79425.TM0801	25	20	12	10	15	5	M8	8	10
G79440.0001	G79440.TM0801	40	30	18	18	22	7	M8	15	25
-	G79540.TM1001	40	30	18	18	22	7	M10	14	26
G79440.0004	G79440.TM1201	40	30	18	18	22	7	M12	14	28

# G795

## KNOB WITH THREADED STUD



### Materials:

Reinforced polyamide.  
Resistant to oils and greases.

### Surface finish:

Satin.

### Colour:

Black (RAL 9011).

### Inserts:

Galvanised steel threaded stud (thread tolerance 6g).

### Special requests:

- Upon request and for special quantities inserts can be supplied with customised lengths.
- Upon request and for special quantities inserts can be supplied in different materials.
- Upon request and for special quantities available in the colours indicated in the chart [page 959].

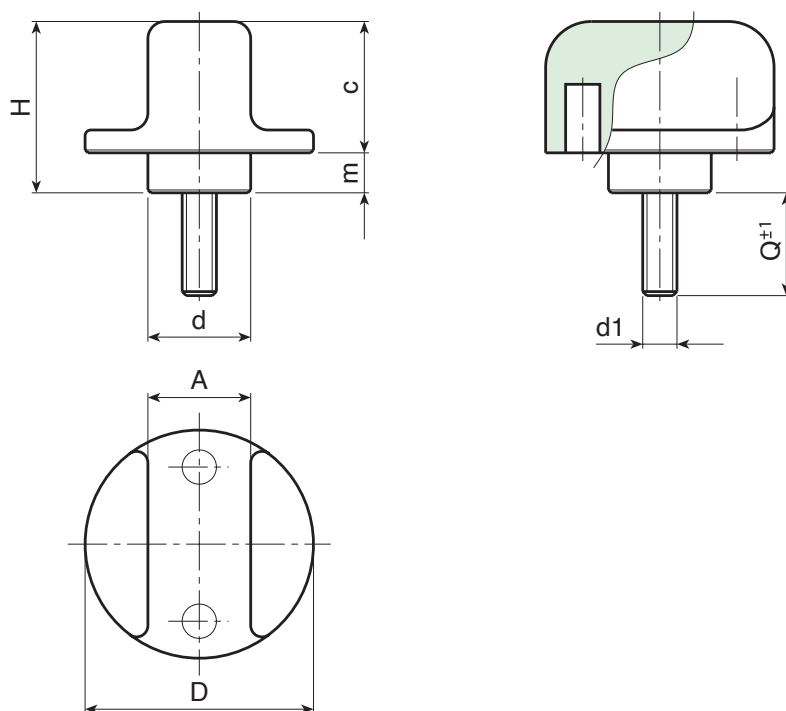

Code	art.	D	H	d	A	c	m	LM	d1 <sub>6g</sub>	Q	g
G79525.0006	G79525.TM05X1601	25	20	12	10	15	5	40	M5	16	12
G79525.0022	G79525.TM06X3001	25	20	12	10	15	5	40	M6	30	14
G79525.0031	G79525.TM08X2001	25	20	12	10	15	5	40	M8	20	25
G79540.0014	G79540.TM08X3001	40	30	18	18	22	7	50	M8	30	40
G79540.0024	G79540.TM10X3001	40	30	18	18	22	7	50	M10	30	43
G79540.0032	G79540.TM12X4001	40	30	18	18	22	7	50	M12	40	67

Customised stud lengths available for a minimum of 150 pieces.  
LM = Maximum mouldable length.



# G796

## KNOB WITH THREADED INSERT



### Materials:

Reinforced polyamide.  
Resistant to oils and greases.

### Surface finish:

Satin.

### Colour:

Black (RAL 9011).

### Inserts:

Brass insert with female threaded hole (thread tolerance 6H).

### Special requests:

- Upon request and for special quantities inserts can be supplied in different materials.
- Upon request and for special quantities available in the colours indicated in the chart [page 959].



07

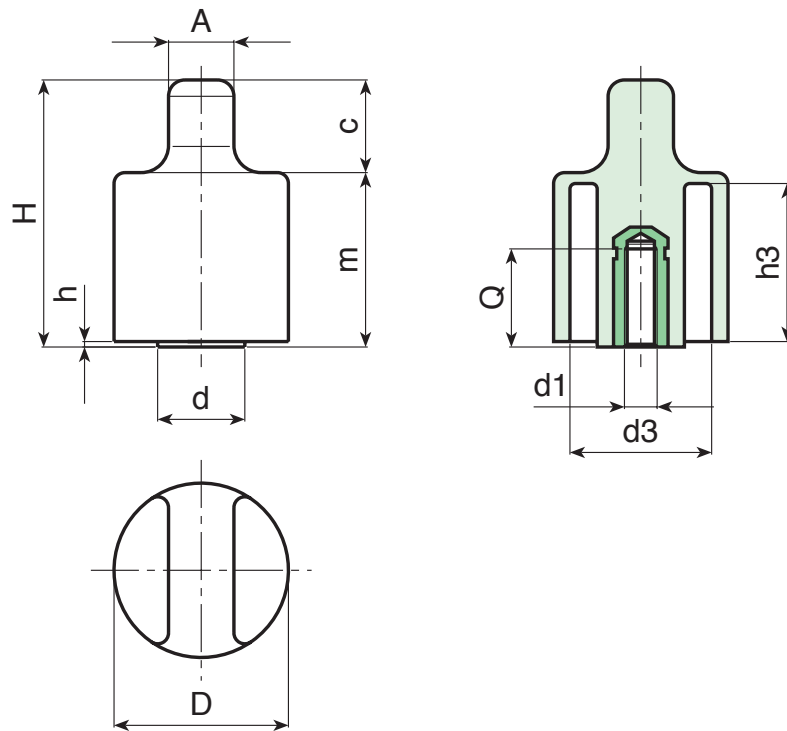

Code	art.	D	H	d	A	c	m	h	h3	d3	d16H	Q	
G79632.0001	G79632.TM0601	32	49	16	12	15	34	1	29	25.5	M6	16	33
G79632.0003	G79632.TM0801	32	49	16	12	15	34	1	29	25.5	M8	14	35
G79632.0005	G79632.TM1001	32	49	16	12	15	34	1	29	25.5	M10	13	36

# G797

## KNOB WITH THREADED STUD



### Materials:

Reinforced polyamide.  
Resistant to oils and greases.

### Surface finish:

Satin.

### Colour:

Black (RAL 9011).

### Inserts:

Galvanised steel threaded stud (thread tolerance 6g).

### Special requests:

- Upon request and for special quantities inserts can be supplied with customised lengths.
- Upon request and for special quantities inserts can be supplied in different materials.
- Upon request and for special quantities available in the colours indicated in the chart [page 959].

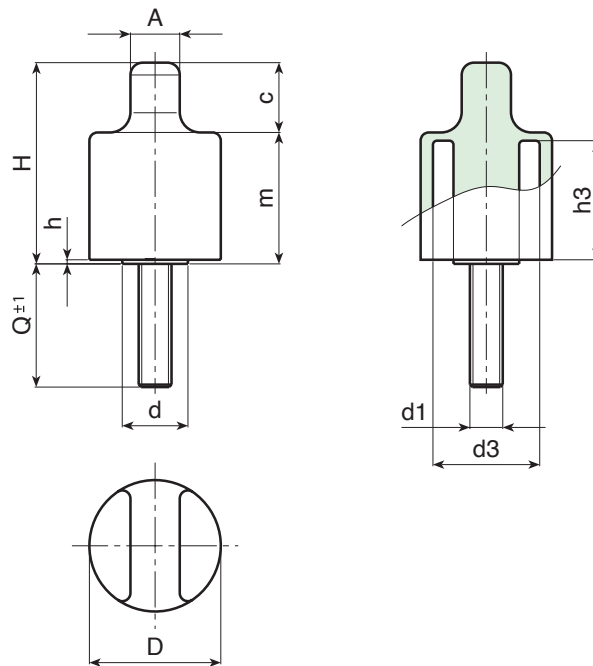

Code	art.	D	H	d	A	c	m	h	h3	d3	LM	d1 <sub>6g</sub>	Q	g
G79732.0002	G79732.TM06X2001	32	49	16	12	15	34	1	29	25.5	60	M6	20	37
G79732.0005	G79732.TM08X2501	32	49	16	12	15	34	1	29	25.5	60	M8	25	43
G79732.0011	G79732.TM12X2001	32	49	16	12	15	34	1	29	25.5	60	M12	20	59

Customised stud length available for a minimum of 250 pieces.  
LM = Maximum mouldable length.



# G798

## ELONGATED KNOB WITH THREADED INSERT



### Materials:

Reinforced polyamide.  
Resistant to oils and greases.

### Surface finish:

Satin.

### Colour:

Black (RAL 9011).

### Inserts:

Brass insert with female threaded hole (thread tolerance 6H).

### Special requests:

- Upon request and for special quantities inserts can be supplied in different materials.
- Upon request and for special quantities available in the colours indicated in the chart [page 959].



07

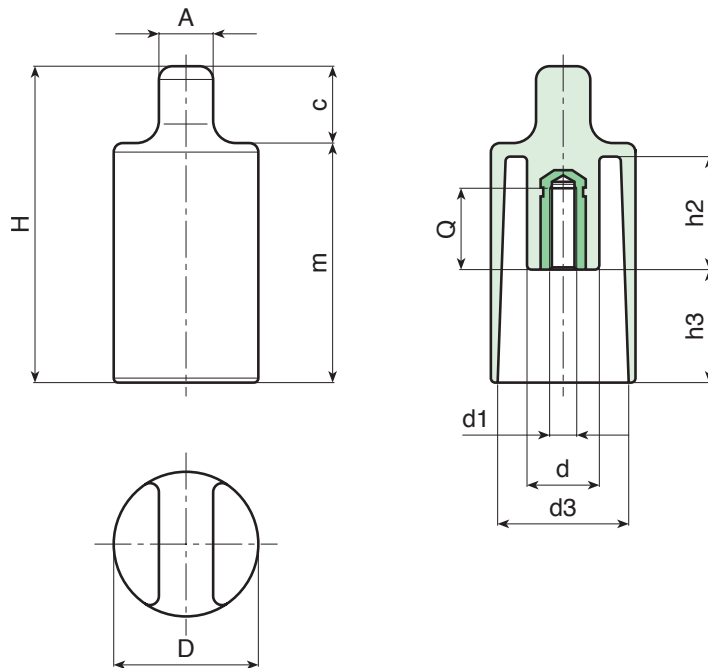

Code	art.	D	H	d	A	c	m	h2	h3	d3	d1 <sub>6H</sub>	Q	g
G79832.0001	G79832.TM0601	32	69	12	12	15	54	25	26	28	M6	22	32
G79832.0003	G79832.TM0801	32	69	12	12	15	54	25	26	28	M8	20	38

# G799

## ELONGATED KNOB WITH THREADED STUD



### Materials:

Reinforced polyamide.  
Resistant to oils and greases.

### Surface finish:

Satin.

### Colour:

Black (RAL 9011).

### Inserts:

Galvanised steel threaded stud (thread tolerance 6g).

### Special requests:

- Upon request and for special quantities inserts can be supplied in different materials.
- Upon request and for special quantities available in the colours indicated in the chart [page 959].

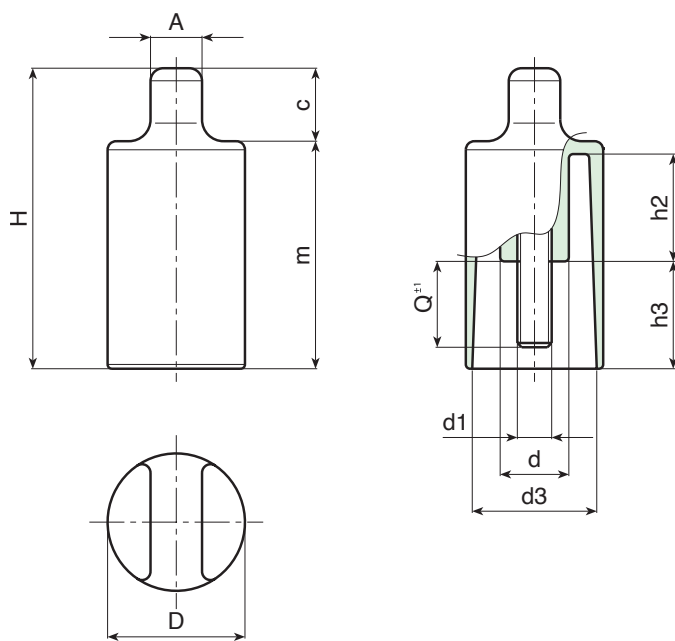

Code	art.	D	H	d	A	c	m	h2	h3	d3	d1 <sub>6g</sub>	Q	
G79932.0001	G79932.TM06X1601	32	69	12	12	15	54	25	26	28	M6	16	40
G79932.0004	G79932.TM08X1601	32	69	12	12	15	54	25	26	28	M8	16	48