

R258



POLYAMIDE / POLYURETHANE WHEEL WITH RECTANGULAR SWIVEL STEEL PLATE WITH BRAKE AND BEARINGS (HEAVY DUTY SERIES)

Materials:

Wheel body (1):

Polyamide. Resistant to oils and greases.

Tread (2):

Injected polyurethane. Hardness 60 ± 5 Shore D.

Surface finish:

Smooth.

Colour:

(1) Natural white.

(2) Red (Ral 3013).

(3-4-5-6) Galvanised blue.

Wheel rotation (4):

A pair of steel ball bearings is inserted in the wheel hub to provide excellent rollability.

Bracket (3):

Extra-thick steel (DD13) fork, with integrated brake.

Rotating assembly (5):

Steel rotating assembly with double ball race, assembled with steel screw grade 8.8 and rectangular swivel plate with four slotted mounting holes.

Wheel fastening (6):

Steel hex head screw, coupled with a self-locking steel nut.

Special requests:

- Upon request and for a minimum of 20 pieces, the wheel can be supplied with a needle roller cage, (replace code no. R258 with code no. R248).

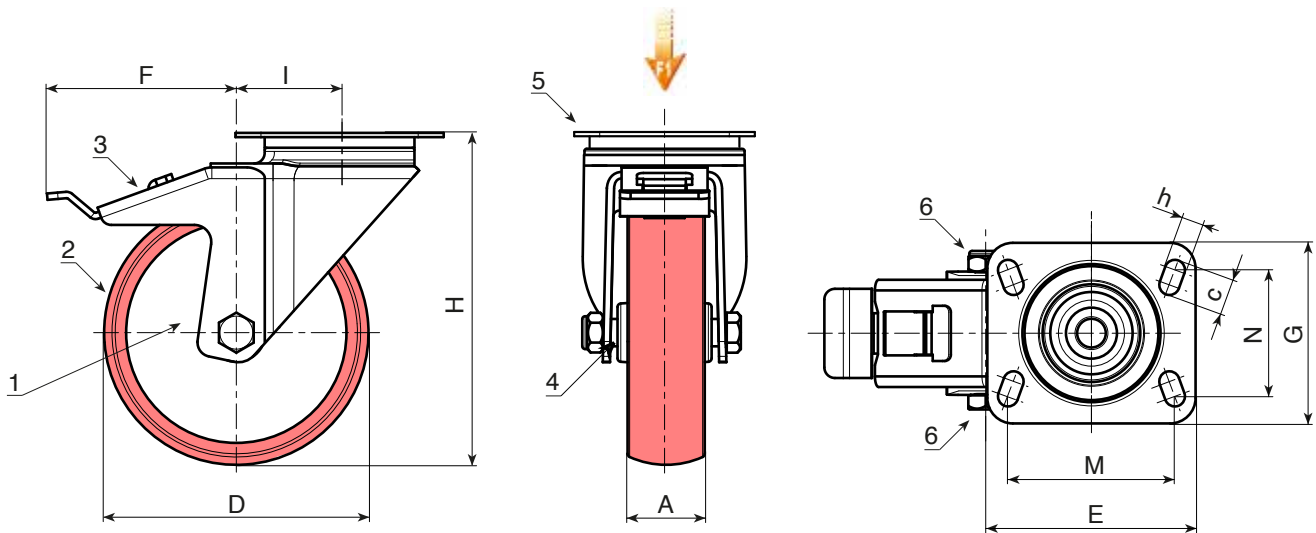

Code	art.	D	A	H	I	E	G	M	N	c	h	F	g	F1 (Kg)
-	R258080.T34P080X060	80	34	125	47	100	84	80	60	12	9	113	-	260
-	R258100.T40P080X060	100	40	135	47	100	84	80	60	12	9	114	-	300
-	R258125.T40P080X060	125	40	161	51	100	84	80	60	12	9	128	-	400
-	R258150.T45P105X080	150	45	195	60	132	110	105	80	23	12	157	-	600
-	R258200.T50P105X080	200	50	242	59	132	110	105	80	23	12	158	-	700