

M145

REVOLVING HANDLE WITH RING NUT



Materials:

Reinforced polyamide.
Resistant to oils and greases.

Surface finish:

Satin.

Colour:

Black (RAL 9011).

Inserts:

M145:

Revolving galvanised steel threaded stud, with ring nut with seat for key and harmonic steel rotating spring (thread tolerance 6g).

M145CIN:

Revolving stainless steel threaded stud (Aisi 303), with ring nut with seat for key and stainless steel rotating spring (Aisi 302) (thread tolerance 6g).

Special Requests:

- Upon request and for special quantities available in the colours indicated in the chart [page].

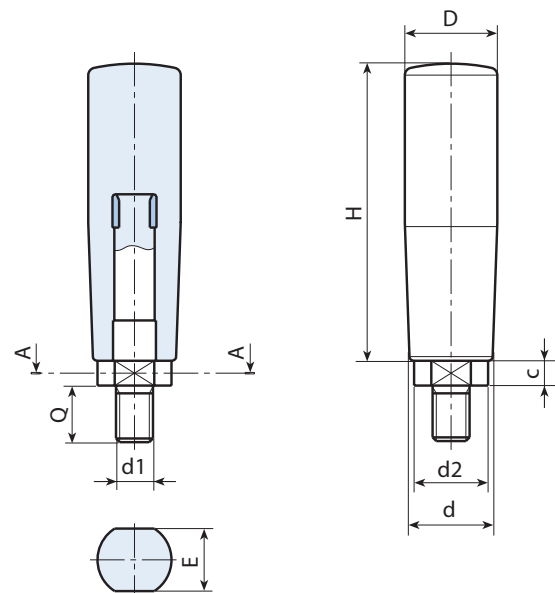

Version M145: with galvanised steel inserts.

Code	art.	H	D	d	d2	c	E	d1 _{6g}	Q	
-	M14550.TM06X1201	50,5	20	15	12	5	10	M6	12	32
-	M14560.TM08X1501	60,5	23,5	18	14	7	13	M8	15	74
-	M14570.TM08X1501	70	25	18,5	14	7	13	M8	15	82
-	M14570.TM10X1501	70	25	18,5	14	7	13	M10	15	86
-	M14580.TM10X1501	79	26	21,5	18	6,5	16	M10	15	92
-	M14580.TM12X1501	79	26	21,5	18	6,5	16	M12	15	96
-	M14590.TM10X1501	89,5	28	23,5	18	6,5	16	M10	15	104
-	M14590.TM12X1501	89,5	28	23,5	18	6,5	16	M12	15	108

Version M145CIN: with stainless steel inserts (Aisi 303).



Code	art.	H	D	d	d2	c	E	d1 _{6g}	Q	
-	M14550.TM06X1201CIN	50,5	20	15	12	5	10	M6	12	32
-	M14560.TM08X1501CIN	60,5	23,5	18	14	7	13	M8	15	74
-	M14570.TM08X1501CIN	70	25	18,5	14	7	13	M8	15	82
-	M14570.TM10X1501CIN	70	25	18,5	14	7	13	M10	15	86
-	M14580.TM10X1501CIN	79	26	21,5	18	6,5	16	M10	15	92
-	M14580.TM12X1501CIN	79	26	21,5	18	6,5	16	M12	15	96
-	M14590.TM10X1501CIN	89,5	28	23,5	18	6,5	16	M10	15	104
-	M14590.TM12X1501CIN	89,5	28	23,5	18	6,5	16	M12	15	108