

UNIVERSAL QUARTER TURN PLASTIC CAM LOCK M22 THREAD WITH WING PIN SOCKET KEY

Materials:

- (1) Lock body M22x1.5 (stator) in reinforced PA6.6 polyamide. Resistant to oils and greases.
- (2) Groove shaped for wing pin key, in reinforced PA6.6 polyamide.
- (3) Die-cast zamak hexagon lock nut M22x1,5.
- (4) Rubber gasket.
- (5) Steel cam (E=0 straight, E=2,4,6,8,10 formed out, E=-2 formed in).
- (6) Phillips steel fixing screw M6x10.

Surface finish:

- (1) Satin.
- (2-3-4-5-6) Smooth.

Colour:

- (1) Black (RAL 9011).
- (2-3-4-5-6) Standard galvanising.

Key (optional):

Red polyamide key (PA6), art. J090.
ATTENTION: The key is not supplied. To be ordered separately. [page 319].

Rotation: 90°

Special Requests:

- Upon request the key can be supplied with the lock. Add letter C at the end of the main code.

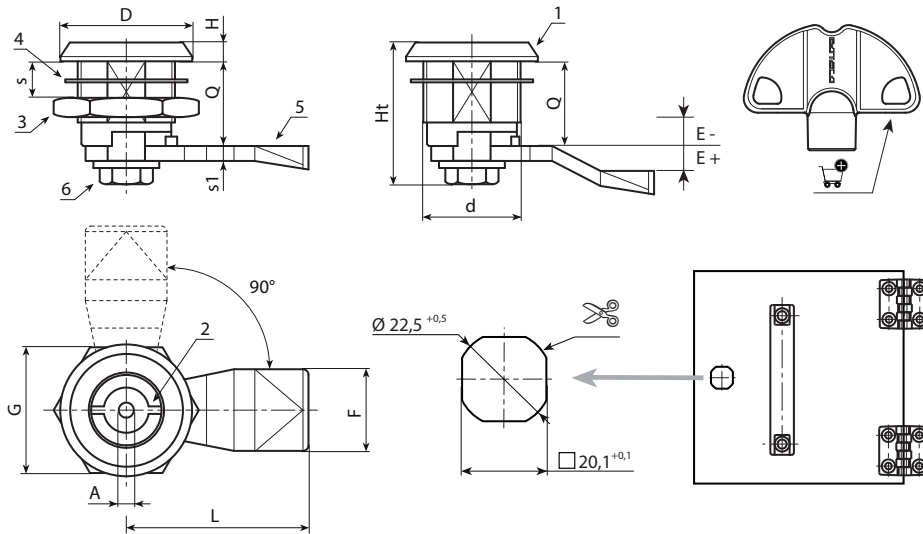

Code	Art.	A	d	D	L	Q	E	F	G	Ht	H	S(max.)	s1	g	Key
-	J12422.T03E-4X4501	3	M22	28	45	18	-4	19	27	31,5	4	8	4	-	J090050. TP0316
-	J12422.T03E-2X4501	3	M22	28	45	18	-2	19	27	31,5	4	8	4	-	J090050. TP0316
-	J12422.T03E00X4501	3	M22	28	45	18	0	19	27	31,5	4	8	4	-	J090050. TP0316
-	J12422.T03E02X4501	3	M22	28	45	18	2	19	27	31,5	4	8	4	-	J090050. TP0316
-	J12422.T03E04X4501	3	M22	28	45	18	4	19	27	31,5	4	8	4	-	J090050. TP0316
-	J12422.T03E06X4501	3	M22	28	45	18	6	19	27	31,5	4	8	4	-	J090050. TP0316
-	J12422.T03E08X4501	3	M22	28	45	18	8	19	27	31,5	4	8	4	-	J090050. TP0316
-	J12422.T03E10X4501	3	M22	28	45	18	10	19	27	31,5	4	8	4	-	J090050. TP0316
-	J12422.T03E12X4501	3	M22	28	45	18	12	19	27	31,5	4	8	4	-	J090050. TP0316