

# Y508

## DIN 508 - T-SHAPED STEEL NUT FOR SLOTS



**Materials:**

Steel with class 8 tensile strength.

**Surface finish:**

Smooth.

**Colour:**

Black-oxide treated.

**Hole:**

Threaded through hole (thread tolerance 6H).

**Special requests:**

- The product can be supplied with galvanised finish. Replace the "SBM" portion of the code with "SZM".

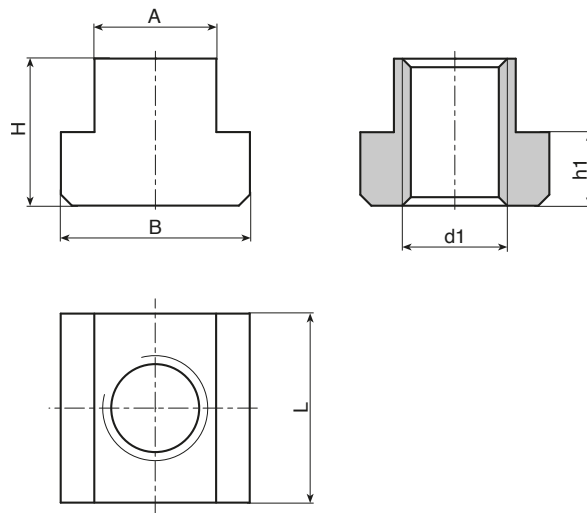

Code	art.	A-0,3/+0,5	B-0,5	L-0,5	h1-0,5	H	T slot DIN508	d16H	g
-	Y508005.SBM0408	5	9	9	3	5,5	5	M4	2
-	Y508006.SBM0508	6	10	10	4	8	6	M5	4
-	Y508008.SBM0608	8	13	13	6	10	8	M6	8
-	Y508010.SBM0808	9,5	16	20	6,5	12	10	M8	12
-	Y508012.SBM1008	12	19	22	6,5	12	12	M10	20
-	Y508014.SBM1208	14	22	26	8	16	14	M12	34
-	Y508015.SBM1208	15	23,5	28	8	16	15	M12	47
-	Y508018.SBM1608	18	28	30	10,5	20	18	M16	62
-	Y508022.SBM2008	22	35	39	14,5	27	22	M20	149
-	Y508028.SBM2408	27	41	42,5	17	33,5	28	M24	314
-	Y508036.SBM3008	35	53	53	22,5	44	36	M30	586