

# Y319



## DIN 6319 ed. 10/01 - PODKŁADKA WYPUKŁA - KSZTAŁT C - ZE STALI

### Materiały:

**Y319:**  
Stal nawęglana.  
**Y319PIN:**  
Stal inox (AISI 303).

### Powierzchnia:

**Y319:**  
Gładka, nawęglana.  
**Y319PIN:**  
Naturalna, nie obrabiana.

### Kolor:

**Y319:**  
Oksydowanie standardowe.  
**Y319PIN:**  
Naturalny.

### Wykonanie na specjalne zamówienie:

- Nie uwzględnia się.

### Uwagi:

Uwaga: podkładkę wypukłą Y319 należy stosować w zestawieniu z podkładką wklęsłą, model Y320 lub Y321, do osobnego zamówienia.

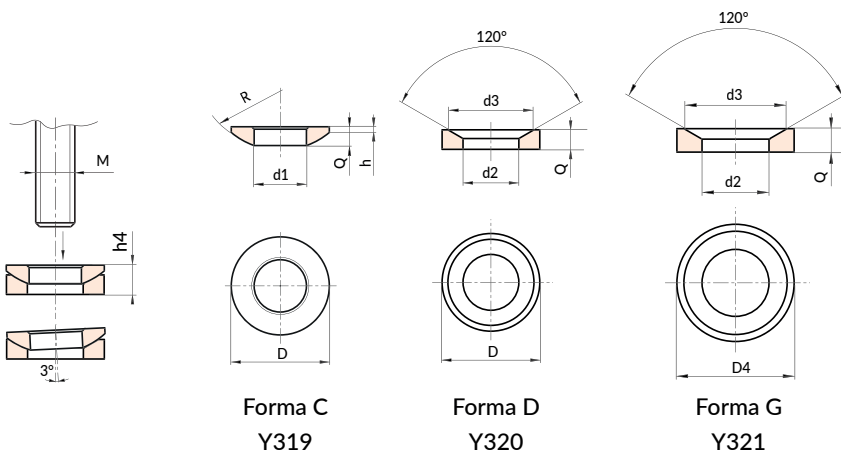

17

### Wersja DIN 6319 kształt C - podkładka wypukła ze stali oksydowanej

Kod	Art.	D	R	h	d1 <sub>H13</sub>	M	Q	Max dopuszczalne obciążenie statyczne kN	
Y319010.0001	Y319010.SD05.25	10.5	7.5	0.4	5.25	M05	2	-	0.7
Y319012.0002	Y319012.SD06.4	12	9	0.7	6.4	M06	2.3	9	1
Y319017.0002	Y319017.SD08.4	17	12	0.6	8.4	M08	3.2	17	2.8
Y319021.0002	Y319021.SD10.5	21	15	0.8	10.5	M10	4	26	5
Y319024.0002	Y319024.SD13	24	17	1.1	13	M12	4.6	38	8
Y319028.0001	Y319028.SD15	28	22	1.2	15	M14	5	53	11
Y319030.0002	Y319030.SD17	30	22	1.3	17	M16	5.3	73	13
Y319036.0002	Y319036.SD21	36	27	2	21	M20	6.3	117	23
Y319044.0002	Y319044.SD25	44	32	2.4	25	M24	8.2	168	21
Y319056.0002	Y319056.SD31	56	41	3.6	31	M30	11.2	269	103
Y319068.0002	Y319068.SD37	68	50	4.6	37	M36	14	394	188
Y319078.0002	Y319078.SD43	78	58	6.5	43	M42	17	542	316
Y319092.0002	Y319092.SD50	92	67	8	50	M48	21	714	549
Y319103.0001	Y319103.SD58	103	79	9.5	58	M56	23	-	748
Y319120.0001	Y319120.SD66	120	93	12	66	M64	27	-	1239



### Wersja DIN 6319 kształt C - podkładka wypukła ze stali inox (AISI 303)

Kod	Art.	D	R	h	d1 <sub>H13</sub>	M	Q	Max dopuszczalne obciążenie statyczne kN	
Y319012.0001	Y319012.ID06.4PIN	12	9	0.7	6.4	M06	2.3	6	1
Y319017.0001	Y319017.ID08.4PIN	17	12	0.6	8.4	M08	3.2	12	2.8
Y319021.0001	Y319021.ID10.5PIN	21	15	0.8	10.5	M10	4	16	5
Y319024.0001	Y319024.ID13PIN	24	17	1.1	13	M12	4.6	24	7
Y319030.0001	Y319030.ID17PIN	30	22	1.3	17	M16	5.3	45	13
Y319036.0001	Y319036.ID21PIN	36	27	2	21	M20	6.3	71	24
Y319044.0001	Y319044.ID25PIN	44	32	2.4	25	M24	8.2	105	44
Y319056.0001	Y319056.ID31PIN	56	41	3.6	31	M30	11.2	191	106
Y319068.0001	Y319068.ID37PIN	68	50	4.6	37	M36	14	-	194
Y319078.0001	Y319078.ID43PIN	78	58	6.5	43	M42	17	-	311
Y319092.0001	Y319092.ID50PIN	92	67	8	50	M48	21	-	550