

W795

KNOB WITH STEEL INDEXING PLUNGER



Materials:

- (1) Stainless steel plunger pin (Aisi 303).
- (4) Reinforced polyamide lobed knob. Cannot be disassembled. Resistant to oils and greases.

W795:

- (2) Indexing plunger body in free-cutting steel.
- (3) Galvanised steel spring.

W795 CIN:

- (2) Stainless steel (Aisi 303) indexing plunger body.
- (3) Stainless steel spring (Aisi 301).

Surface finish:

- (4) Satin.
- (1-2-3) Smooth.

Colour:

- (4) Black (RAL 9011).

W795:

- (2) Galvanised.

W795 CIN:

- (1-2) Natural.

ATTENTION:

> We recommend an H7 tolerance for the plunger stem bore.

Special Requests:

- None.

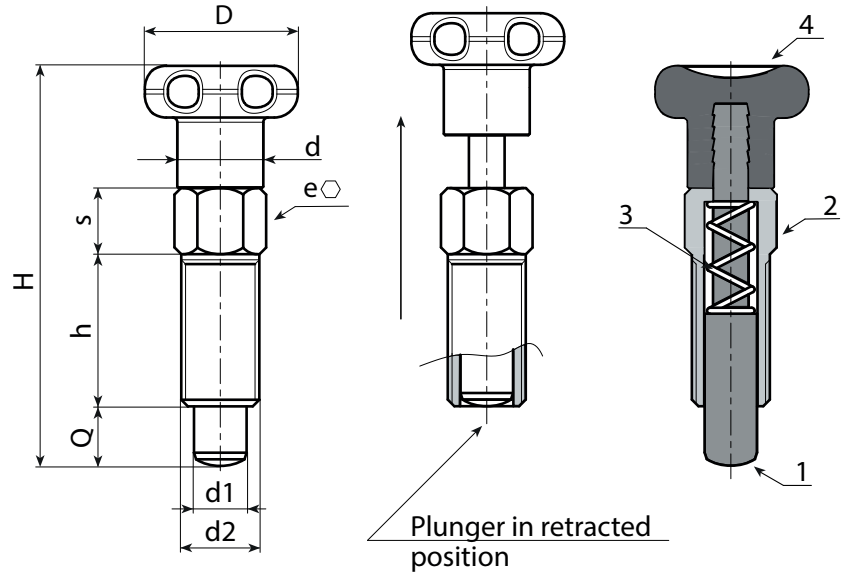

Version W795 - galvanised steel

Code	Art.	D	d	H	h	e	s	d2	d1 -0,02 -0,04	Q	g
-	W795.J0401	14	7	33	12	6	5	M6	4	4	5
-	W795.J0501	18	9	42	16	8	6	M8	5	5	11
-	W795.J0601	22	11	52	20	10	7,5	M10	6	6	23
-	W795.J0801	24	13	61	24	12	9	M12	8	8	38

Version W795 CIN - stainless steel (Aisi 303)

INOX

Code	Art.	D	d	H	h	e	s	d2	d1 -0,02 -0,04	Q	g
-	W795.J0401CIN	14	7	33	12	6	5	M6	4	4	5
-	W795.J0501CIN	18	9	42	16	8	6	M8	5	5	11
-	W795.J0601CIN	22	11	52	20	10	7,5	M10	6	6	23
-	W795.J0801CIN	24	13	61	24	12	9	M12	8	8	38