

W624



VERLENGD STALEN VEREND DRUKSTUK MET DRUKPEN

Materiaal:

Lichaam drukstuk gedraaid en getapt, in staal met sterkteklasse 5.8.

Oppervlak:

Glad.

Kleur:

Gebruineerd zwart.

Drukpen:

Gedraaide drukpen in gehard staal met hoge sterkteklasse.

Veer:

Veer in harmonisch staal.

Types veerkracht:

Normaal.

Speciale verzoeken:

- Geen.

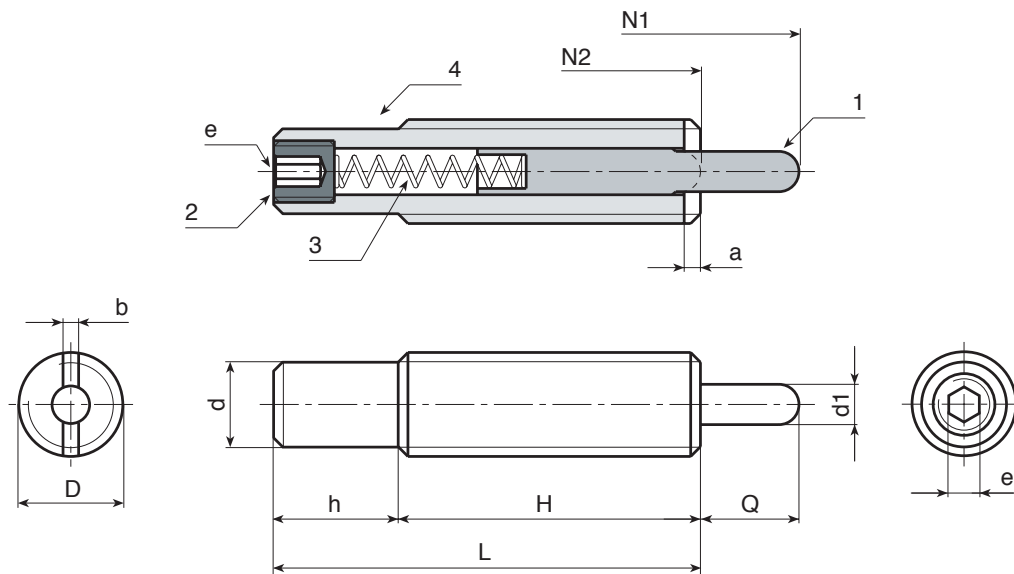

Code	art.	L	D	H	h	d	a	b	e	d1	Q	g	N1 (N)	N2 (N)
-	W624030.VBM08Q03.5X06	30	M08	20	10	6.2	1.4	1.2	2.5	3.5	6	9	8	20
-	W624040.VBM08Q03.5X08	40	M08	20	20	6.2	1.4	1.2	2.5	3.5	8	10	10	28
-	W624050.VBM08Q03.5X10	50	M08	20	30	6.2	1.4	1.2	2.5	3.5	10	10	12	38
-	W624060.VBM08Q03.5X15	60	M08	20	40	6.2	1.4	1.2	2.5	3.5	15	14	15	48
-	W624040.VBM10Q04X08	40	M10	30	10	8	1.4	1.6	3	4	8	15	12	30
-	W624050.VBM10Q04X10	50	M10	30	20	8	1.4	1.6	3	4	10	18	16	46
-	W624060.VBM10Q04X15	60	M10	30	30	8	1.4	1.6	3	4	15	21	20	55
-	W624080.VBM10Q04X20	80	M10	30	50	8	1.4	1.6	3	4	20	28	25	65
-	W624050.VBM12Q06X10	50	M12	30	20	9.6	2	2	4	6	10	28	20	50
-	W624060.VBM12Q06X15	60	M12	30	30	9.6	2	2	4	6	15	31	25	76
-	W624080.VBM12Q06X20	80	M12	30	50	9.6	2	2	4	6	20	40	35	102
-	W624100.VBM12Q06X25	100	M12	30	70	9.6	2	2	4	6	25	47	40	102
-	W624060.VBM16Q07.5X12	60	M16	30	30	13.4	2.5	2.5	5	7.5	12	63	30	64
-	W624080.VBM16Q07.5X10	80	M16	30	50	13.4	2.5	2.5	5	7.5	10	80	30	110
-	W624100.VBM16Q07.5X30	100	M16	30	70	13.4	2.5	2.5	5	7.5	30	100	30	120
-	W624120.VBM16Q07.5X40	120	M16	30	90	13.4	2.5	2.5	5	7.5	40	118	20	130