

# W296



Al

PA6  
+G.F.

UL94  
HB



## ALUMINIUM CONTROL HANDWHEEL WITH SMOOTH BORE

### Materials:

Die-cast aluminium.

### Surface finish:

Satin finish, except for the sections (T) with low surface roughness obtained by turning.

### Colour:

Nickel plated (galvanic treatment).

### Alternative colours (min. 50 pieces):

Black epoxy powder coated:  
(replace the final letter of the code (H) with letter V (W296100.  
AD10V).

### Cap:

Central cap in black polyamide (RAL 9011 code 01).

### Alternative Cap colours:

The central cap for the black handwheel will be grey (RAL 7035 code no. 13).

### Hole:

Smooth through hole, remachined with H7 tolerance.

### Fixing method:

For fixing systems, or execution of keyways or square holes, please refer to the technical notes attached to the catalogue.

### Special Requests:

- Upon request and for special quantities handwheels can be supplied on customer's drawing with hole diameter d1.

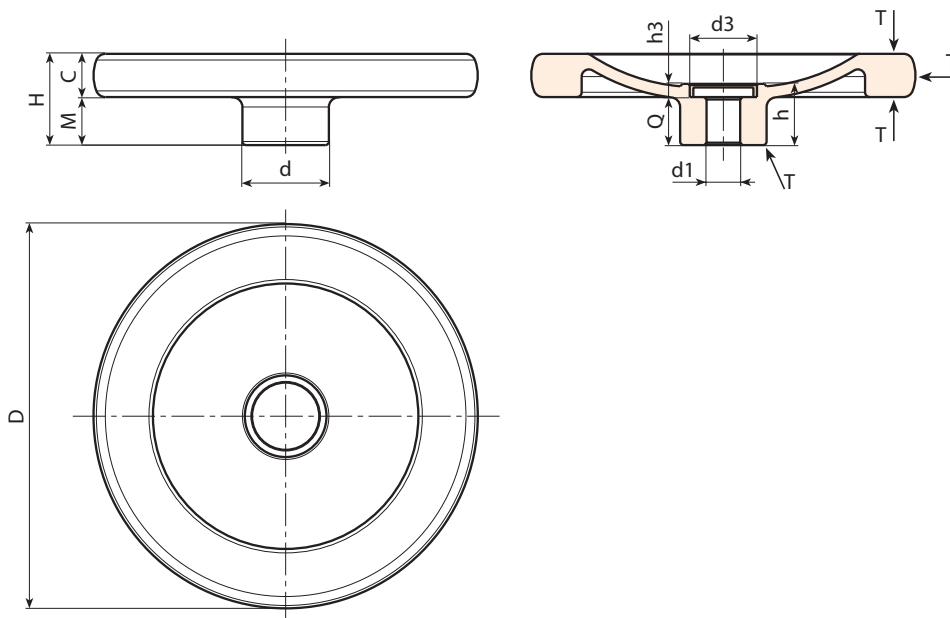

Code	Art.	d	D	H	m	c	h	h3	d3	d1 <sub>H7</sub>	Q	g
-	W296080.AD08H	26	80	26	14	12	21	5.5	20	8	15.5	142
-	W296100.AD10H	28	100	28	14	14	21.5	5.5	20	10	16	240
-	W296130.AD12H	36	130	35	19	16	25.5	5.5	28	12	20	435
-	W296160.AD14H	36	160	38	20	18	25.5	5.5	28	14	20	685
-	W296200.AD16H	42	200	44	24	20	31.5	6	34	16	25.5	1185

Attention: For a minimum of 50 pieces the diameter d1 can be customised (hole tolerance H7).