

# R257



## POLYAMIDE / POLYURETHANE WHEEL WITH RECTANGULAR SWIVEL PLATE AND STEEL BEARINGS (HEAVY DUTY SERIES)

### Materials:

#### Wheel body (1):

Polyamide. Resistant to oils and greases.

#### Tread (2):

Injected polyurethane. Hardness  $60 \pm 5$  Shore D.

#### Surface finish:

Smooth.

#### Colour:

(1) Natural white.

(2) Red (Ral 3013).

(3-4-5-6) Galvanised blue.

#### Wheel rotation (4):

A pair of steel ball bearings is inserted in the wheel hub to provide excellent rollability.

#### Bracket (3):

Extra-thick steel (DD13) fork.

#### Rotating assembly (5):

Steel rotating assembly with double ball race, assembled with steel screw grade 8.8 and rectangular swivel plate with four slotted mounting holes.

#### Wheel fastening (6):

Steel hex head screw, coupled with a self-locking steel nut.

#### Special requests:

- Upon request and for a minimum of 20 pieces, the wheel can be supplied with a needle roller cage, (replace code no. R257 with code no. R247).

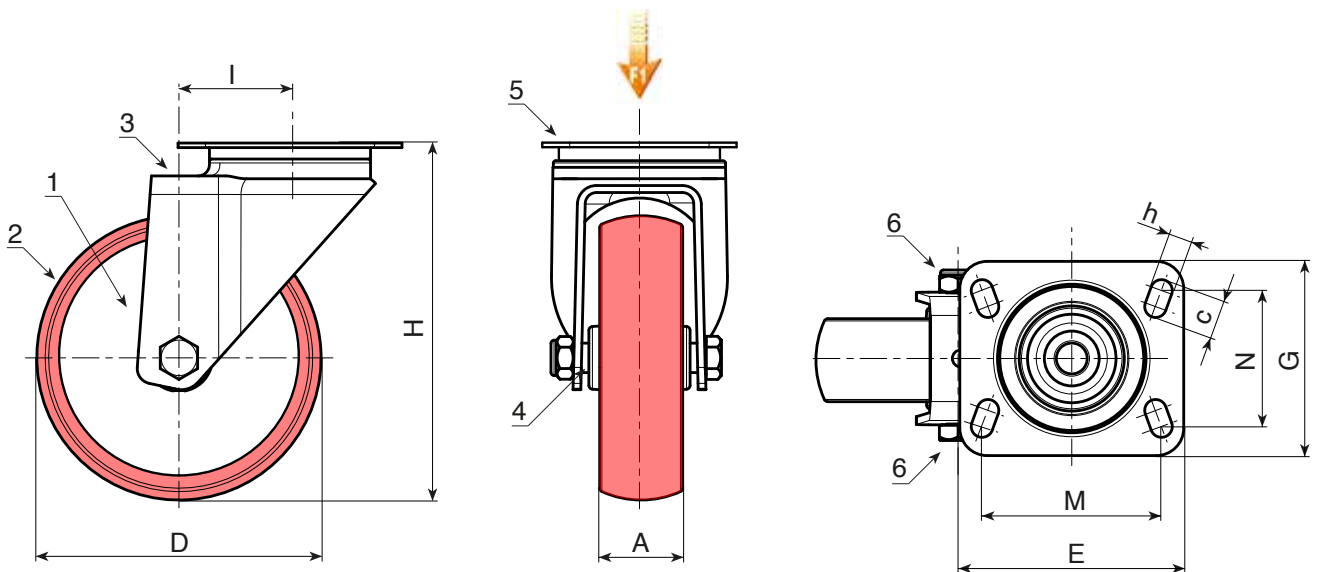

Code	art.	D	A	H	I	E	G	M	N	c	h	$\bar{g}$	F1 (Kg)
-	R257080.T34P080X060	80	34	125	47	100	84	80	60	12	9	-	260
-	R257100.T40P080X060	100	40	135	47	100	84	80	60	12	9	-	300
-	R257125.T40P080X060	125	40	161	51	100	84	80	60	12	9	-	400
-	R257150.T45P105X080	150	45	195	60	132	110	105	80	23	12	-	600
-	R257200.T50P105X080	200	50	242	59	132	110	105	80	23	12	-	700