

# R250



## WHEEL WITH POLYAMIDE BODY AND INJECTED POLYURETHANE TREAD WITH BALL BEARINGS WITHOUT RIG (HEAVY DUTY SERIES)

### Materials:

#### Wheel body:

Polyamide. Resistant to oils and greases.

#### Tread:

Injected polyurethane. Hardness  $60 \pm 5$  Shore D.

### Surface finish:

Smooth.

### Colour:

#### Body:

Natural white.

#### Tread:

Red (Ral 3013).

### Wheel rotation:

(1) A pair of steel ball bearings is inserted in the wheel hub to provide excellent rollability under a heavy load.

### Special requests:

- Upon request and for a minimum of 20 pieces, the wheel can be supplied with a needle roller cage, (replace code no. R250 with code no. R240).

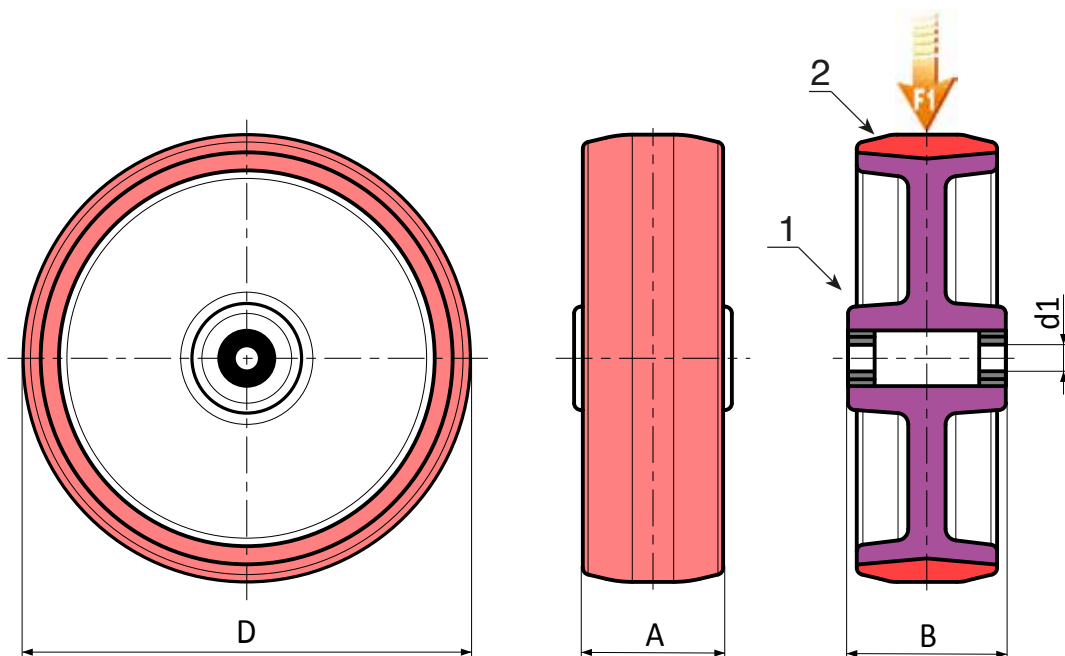

Code	art.	D	A	B	d1	g	F1 (Kg)
-	R250080.T34D12	80	34	40	12	-	260
-	R250100.T40D15	100	40	44	15	-	300
-	R250125.T40D15	125	40	45	15	-	400
-	R250150.T45D20	150	45	58	20	-	600
-	R250200.T50D20	200	50	58	20	-	750