

R207



POLYAMIDE / POLYURETHANE WHEEL WITH RECTANGULAR SWIVEL STEEL PLATE

Materials:

Wheel body (1):

Polyamide. Resistant to oils and greases.

Tread (2):

Injected polyurethane. Hardness 60 ± 5 Shore D.

Surface finish:

Smooth.

Colour:

(1) Natural white.

(2) Red (Ral 3013).

(3-4-5-6) Galvanised blue.

Wheel rotation (4):

The hole for the pivot pin is formed by plastic moulding. A galvanised steel tube is positioned between the stud and the hole for protection.

Bracket (3):

Steel fork (DD13).

Rotating assembly (5):

Steel rotating assembly with double ball race, and rectangular swivel plate with four slotted mounting holes.

Wheel fastening (6):

Steel hex head screw, coupled with a steel nut.

Special requests:

- Upon request and for a minimum of 20 pieces, the wheel can be supplied with a needle roller cage, (replace code no. R207 with code no. R237).

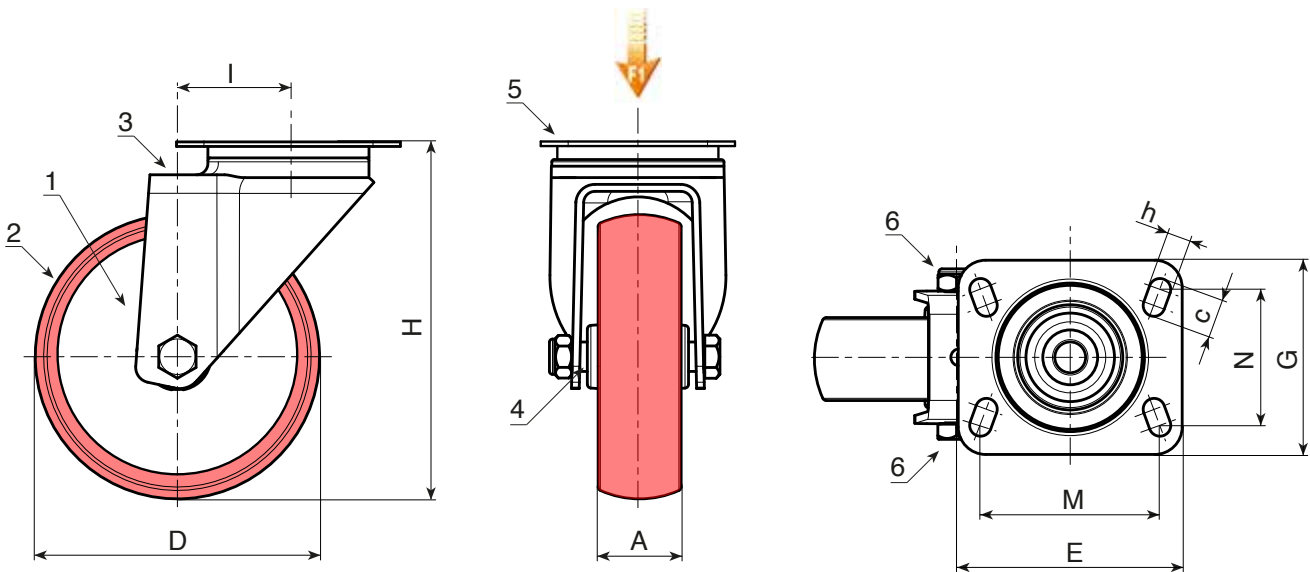

Code	art.	D	A	H	I	E	G	M	N	c	h	\bar{g}	F1 (Kg)
-	R207080.T30P080X060	80	30	108	32	95	80	80	60	12	9	587	100
-	R207100.T30P080X060	100	30	127	32	95	80	80	60	12	9	480	130
-	R207125.T35P080X060	125	35	155	32	95	80	80	60	12	9	790	130
-	R207150.T40P080X060	150	40	184	35	100	80	80	60	12	9	-	140
-	R207200.T50P105X080	200	50	240	48	129	106	105	80	23	11	1691	270