

# R157



## POLYAMIDE MONOLITHIC WHEEL WITH RECTANGULAR SWIVEL STEEL PLATE WITH BEARING (HEAVY DUTY)

### Materials:

#### Wheel body (1):

Polyamide. Resistant to oils and greases.

#### Tread (2):

Polyamide. Resistant to oils and greases.

### Surface finish:

Smooth.

### Colour:

(1-2) Natural white.

(3-4-5-6) Galvanised blue.

### Wheel rotation (4):

A pair of steel ball bearings is inserted to provide excellent rollability.

### Bracket (3):

Extra-thick steel (DD13) fork.

### Rotating assembly (5):

Steel rotating assembly with double ball race, assembled with steel screw grade 8.8 and rectangular swivel plate with four slotted mounting holes.

### Wheel fastening (6):

Steel hex head screw, coupled with a self-locking steel nut.

### Special requests:

- Upon request and for a minimum of 20 pieces, the wheel can be supplied with a needle roller cage, (replace code no. R157 with code no. R147).

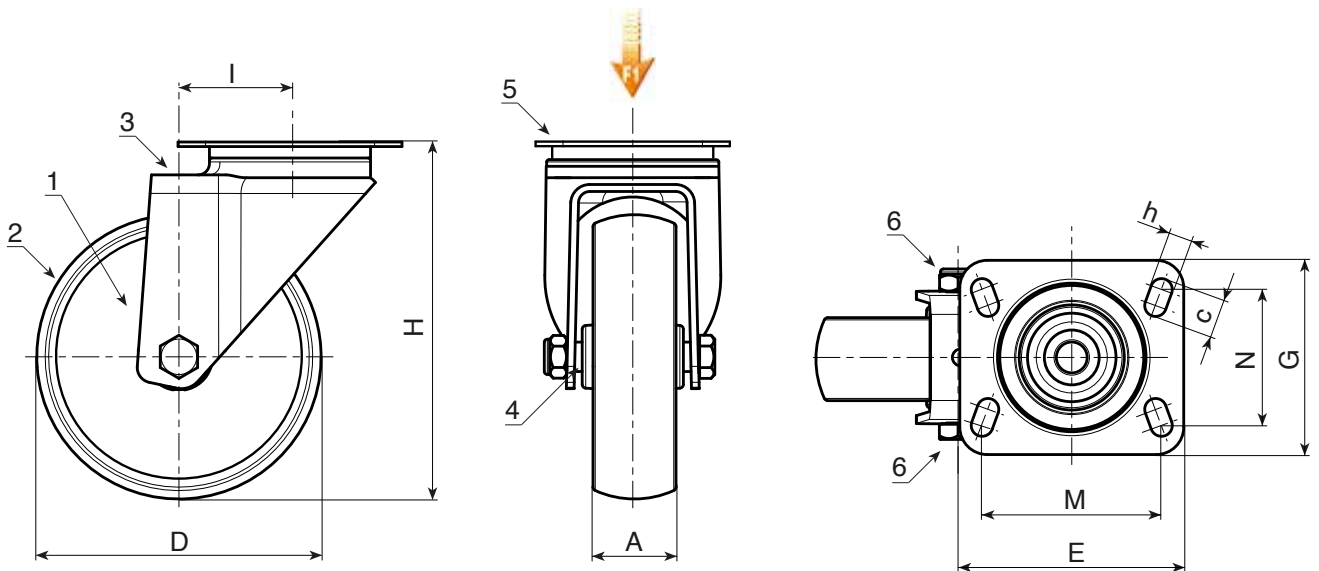

Code	art.	D	A	H	I	E	G	M	N	c	h	g	F1 (Kg)
-	R157100.T35P080X060	100	35	135	47	100	84	80	60	12	9	-	370
-	R157125.T35P080X060	125	35	161	51	100	84	80	60	12	9	-	380
-	R157125.T45P105X080	125	45	164	61	132	110	105	80	23	12	-	600
-	R157150.T40P105X080	150	40	188	45	132	110	105	80	23	12	-	330
-	R157150.T45P105X080	150	45	195	60	132	110	105	80	23	12	-	600
-	R157200.T50P105X080	200	50	242	59	132	110	105	80	23	12	-	600