

R108CIN

INOX

max
4 Km/h

+80°
-25°

PA6

UL94
HB

RoHS
COMPLIANT

POLYAMIDE MONOLITHIC WHEEL WITH RECTANGULAR STAINLESS STEEL SWIVEL PLATE WITH BRAKE

Materials:

Wheel body (1):

Polyamide. Resistant to oils and greases.

Tread (2):

Polyamide. Resistant to oils and greases.

Surface finish:

Smooth.

Colour:

(1-2) Natural white.

(3-4-5-6) Natural stainless steel.

Wheel rotation (4):

The hole for the pivot pin is formed by plastic moulding. A stainless steel (Aisi 304) tube is positioned between the stud and the hole for protection.

Bracket (3):

Stainless steel (Aisi 304) fork, with integrated brake.

Rotating assembly (5):

Stainless steel rotating assembly (Aisi 304) with double stainless steel (Aisi 420) ball race, and rectangular swivel plate with four slotted mounting holes.

Wheel fastening (6):

Stainless steel (Aisi 304) hex head bolt, coupled with a stainless steel (Aisi 304) nut.

Special requests:

- Upon request and for a minimum of 20 pieces, the wheel can be supplied with a needle roller cage, (replace code no. R108CIN with code no. R138CIN).

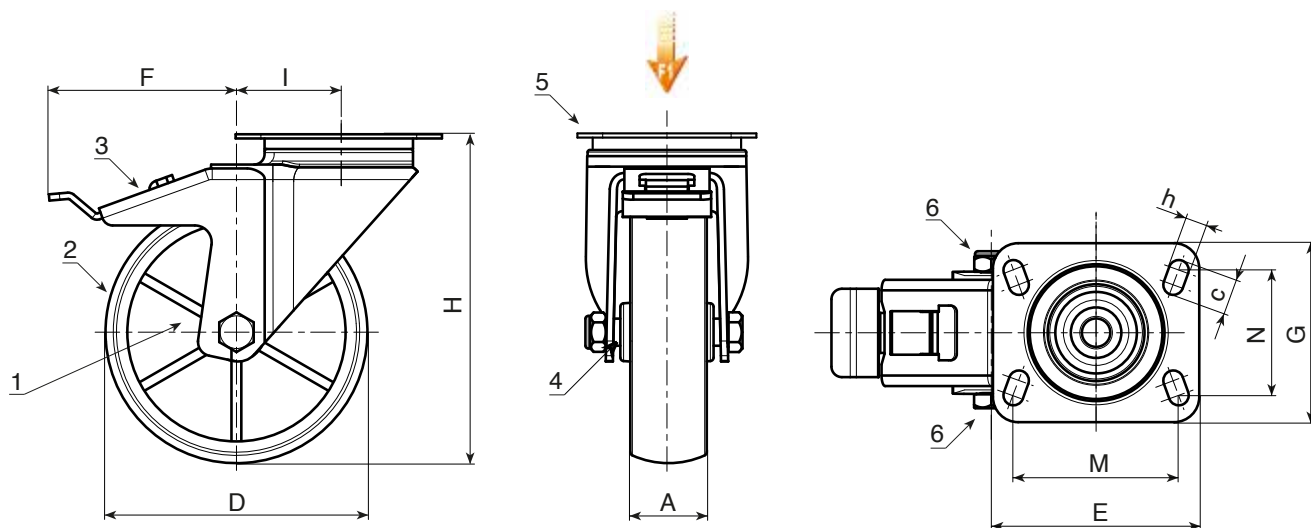

INOX

Code	art.	D	A	H	I	E	G	M	N	c	h	F		F1 (Kg)
-	R108080.T30P080X060CIN	80	30	108	32	95	80	80	60	12	9	110	462	100
-	R108100.T30P080X060CIN	100	30	127	32	95	80	80	60	12	9	110	568	130
-	R108125.T39P080X060CIN	125	39	155	32	95	80	80	60	12	9	113	850	130
-	R108150.T40P080X060CIN	150	40	184	35	95	100	80	60	12	9	115	-	140
-	R108175.T45P105X080CIN	175	45	228	48	129	106	105	80	23	11	150	-	300
-	R108200.T50P105X080CIN	200	50	240	48	129	106	105	80	23	11	150	2402	300