

R102CIN

INOX

max
4 Km/h

+80°
-25°

PA6

UL94
HB

RoHS
COMPLIANT

POLYAMIDE MONOLITHIC WHEEL WITH ROUND STAINLESS STEEL SWIVEL SUPPORT AND SMOOTH THROUGH HOLE WITH BRAKE

Materials:

Wheel body (1):

Polyamide. Resistant to oils and greases.

Tread (2):

Polyamide. Resistant to oils and greases.

Surface finish:

Smooth.

Colour:

(1-2) Natural white.

(3-4-5-6) Natural stainless steel.

Wheel rotation (4):

The hole for the pivot pin is formed by plastic moulding. A stainless steel (Aisi 304) tube is positioned between the stud and the hole for protection.

Bracket (3):

Stainless steel (Aisi 304) fork, with integrated brake.

Rotating assembly (5):

Stainless steel (Aisi 304) rotating assembly with double stainless steel (Aisi 420) ball race and smooth fixing hole, (hole tolerance H7).

Wheel fastening (6):

Stainless steel (Aisi 304) hex head bolt, coupled with a stainless steel (Aisi 304) nut.

Special requests:

- Upon request and for a minimum of 20 pieces, the wheel can be supplied with a needle roller cage, (replace code no. R102CIN with code no. R132CIN).

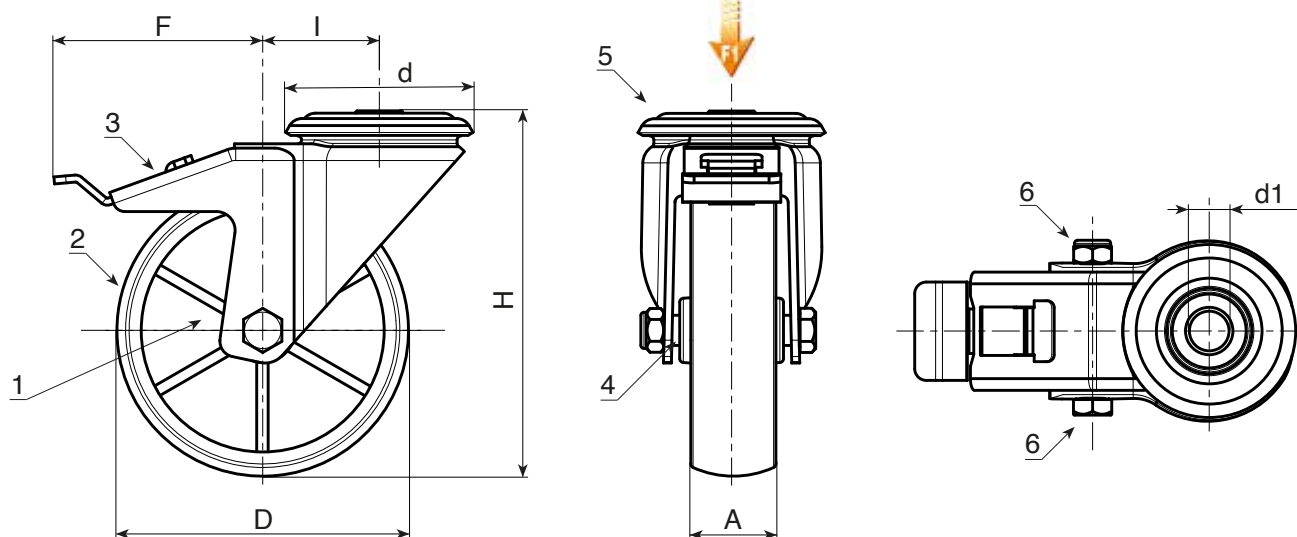

INOX

Code	art.	D	A	H	I	d	F	d1H7	g	F1 (Kg)
-	R102080.T30D12CIN	80	30	108	32	64	110	12	451	100
-	R102100.T30D12CIN	100	30	127	32	64	110	12	706	130
-	R102125.T39D12CIN	125	39	155	32	64	113	12	776	130
-	R102150.T40D12CIN	150	40	184	35	65	115	12	-	140
-	R102175.T45D16CIN	175	45	228	48	95	150	16	-	300
-	R102200.T50D16CIN	200	50	240	48	95	150	16	-	300