

P902



PIED D'APPUI AVEC FIXATION AU SOL, TIGE ARTICULÉE DE TYPE A EN ACIER ET BILLE R15

Matériaux :

Polyamide renforcé. Résistant aux huiles et aux graisses.

Surface :

Satinée.

Couleur :

Noir (RAL 9011).

Inserts :

P902 :
Tige filetée et articulée (bille R.15) avec base hexagonale en acier zingué (tolérance filetage 6g).

P902CIN

Tige filetée et articulée (bille R.15) avec base hexagonale en acier inox (Aisi 303) (tolérance filetage 6g).

Fixation au sol :

Le pied est fourni avec les trous de fixation au sol fermés. Pour les ouvrir, il faut casser la membrane plastique (voir dessin).

Demandes spéciales :

- Sur demande et pour des quantités importantes, les inserts peuvent être fournis avec longueurs sur demande.
- Sur demande et pour des quantités importantes, le pied peut être fourni en orange (RAL 2004).

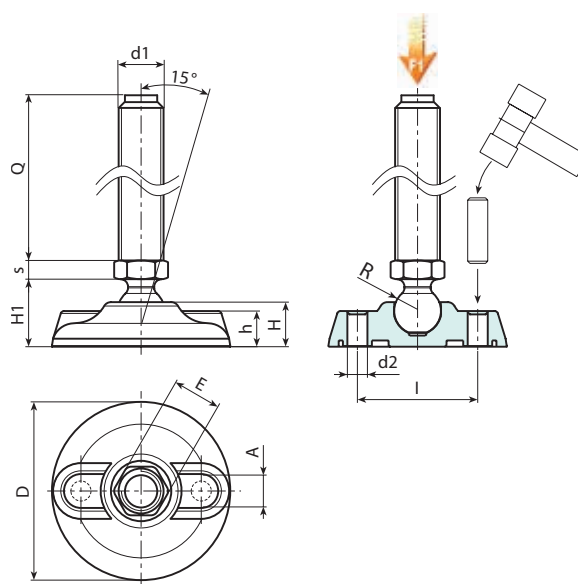

Version P902 : Pied d'appui avec tige de type A (avec hexagone) et bille R15

Code	Art.	D	H	I	H1	h	A	E	s	d2	R	d1 _{6g}	Q	g	F1 (kN)
-	P902080.TM12X5001	80	20	54	25.5	16	20	16	6.5	9	15	M12	50	117	13
-	P902080.TM12X7001	80	20	54	25.5	16	20	16	6.5	9	15	M12	70	130	13
-	P902080.TM12X9001	80	20	54	25.5	16	20	16	6.5	9	15	M12	90	143	13
-	P902080.TM12X11001	80	20	54	25.5	16	20	16	6.5	9	15	M12	110	156	13
-	P902080.TM14X5001	80	20	54	25.5	16	20	16	6.5	9	15	M14	50	126	13
-	P902080.TM14X7001	80	20	54	25.5	16	20	16	6.5	9	15	M14	70	145	13
-	P902080.TM14X9001	80	20	54	25.5	16	20	16	6.5	9	15	M14	90	163	13
-	P902080.TM14X11001	80	20	54	25.5	16	20	16	6.5	9	15	M14	110	181	13
-	P902080.TM14X15001	80	20	54	25.5	16	20	16	6.5	9	15	M14	150	217	13
-	P902080.TM16X5001	80	20	54	25.5	16	20	16	6.5	9	15	M16	50	139	13
-	P902080.TM16X7001	80	20	54	25.5	16	20	16	6.5	9	15	M16	70	166	13
-	P902080.TM16X9001	80	20	54	25.5	16	20	16	6.5	9	15	M16	90	193	13
-	P902080.TM16X11001	80	20	54	25.5	16	20	16	6.5	9	15	M16	110	220	13
-	P902080.TM16X13001	80	20	54	25.5	16	20	16	6.5	9	15	M16	130	247	13
-	P902080.TM16X15001	80	20	54	25.5	16	20	16	6.5	9	15	M16	150	274	13
-	P902080.TM16X17001	80	20	54	25.5	16	20	16	6.5	9	15	M16	170	301	13
-	P902080.TM16X19001	80	20	54	25.5	16	20	16	6.5	9	15	M16	190	328	13
-	P902105.TM12X5001	105	22	74	28	18.5	21	16	6.5	11	15	M12	50	167	15
-	P902105.TM12X7001	105	22	74	28	18.5	21	16	6.5	11	15	M12	70	180	15
-	P902105.TM12X9001	105	22	74	28	18.5	21	16	6.5	11	15	M12	90	193	15
-	P902105.TM12X11001	105	22	74	28	18.5	21	16	6.5	11	15	M12	110	206	15
-	P902105.TM14X5001	105	22	74	28	18.5	21	16	6.5	11	15	M14	50	176	15
-	P902105.TM14X7001	105	22	74	28	18.5	21	16	6.5	11	15	M14	70	195	15
-	P902105.TM14X9001	105	22	74	28	18.5	21	16	6.5	11	15	M14	90	213	15
-	P902105.TM14X11001	105	22	74	28	18.5	21	16	6.5	11	15	M14	110	231	15
-	P902105.TM14X15001	105	22	74	28	18.5	21	16	6.5	11	15	M14	150	268	15
-	P902105.TM16X5001	105	22	74	28	18.5	21	16	6.5	11	15	M16	50	189	15

P902



PIED D'APPUI AVEC FIXATION AU SOL, TIGE ARTICULÉE DE TYPE A EN ACIER ET BILLE R15

Code	Art.	D	H	I	H1	h	A	E	s	d2	R	d1 _{6g}	Q	g	F1 (kN)
-	P902105.TM16X7001	105	22	74	28	18.5	21	16	6.5	11	15	M16	70	216	15
-	P902105.TM16X9001	105	22	74	28	18.5	21	16	6.5	11	15	M16	90	243	15
-	P902105.TM16X11001	105	22	74	28	18.5	21	16	6.5	11	15	M16	110	270	15
-	P902105.TM16X13001	105	22	74	28	18.5	21	16	6.5	11	15	M16	130	297	15
-	P902105.TM16X15001	105	22	74	28	18.5	21	16	6.5	11	15	M16	150	324	15
-	P902105.TM16X17001	105	22	74	28	18.5	21	16	6.5	11	15	M16	170	351	15
-	P902105.TM16X19001	105	22	74	28	18.5	21	16	6.5	11	15	M16	190	378	15
-	P902130.TM12X5001	130	24	99	30	20	21	16	6.5	13	15	M12	50	234	17
-	P902130.TM12X7001	130	24	99	30	20	21	16	6.5	13	15	M12	70	247	17
-	P902130.TM12X9001	130	24	99	30	20	21	16	6.5	13	15	M12	90	260	17
-	P902130.TM12X11001	130	24	99	30	20	21	16	6.5	13	15	M12	110	273	17
-	P902130.TM14X5001	130	24	99	30	20	21	16	6.5	13	15	M14	50	244	17
-	P902130.TM14X7001	130	24	99	30	20	21	16	6.5	13	15	M14	70	263	17
-	P902130.TM14X9001	130	24	99	30	20	21	16	6.5	13	15	M14	90	281	17
-	P902130.TM14X11001	130	24	99	30	20	21	16	6.5	13	15	M14	110	299	17
-	P902130.TM14X15001	130	24	99	30	20	21	16	6.5	13	15	M14	150	335	17
-	P902130.TM16X5001	130	24	99	30	20	21	16	6.5	13	15	M16	50	256	17
-	P902130.TM16X7001	130	24	99	30	20	21	16	6.5	13	15	M16	70	283	17
-	P902130.TM16X9001	130	24	99	30	20	21	16	6.5	13	15	M16	90	310	17
-	P902130.TM16X11001	130	24	99	30	20	21	16	6.5	13	15	M16	110	337	17
-	P902130.TM16X13001	130	24	99	30	20	21	16	6.5	13	15	M16	130	364	17
-	P902130.TM16X15001	130	24	99	30	20	21	16	6.5	13	15	M16	150	391	17
-	P902130.TM16X17001	130	24	99	30	20	21	16	6.5	13	15	M16	170	418	17
-	P902130.TM16X19001	130	24	99	30	20	21	16	6.5	13	15	M16	190	445	17

Attention : La limite de charge F1 exprimée est inférieure de 30 % à la charge de rupture et elle est considérée une valeur statique.
Longueurs pivot sur demande avec un minimum de 100 pièces.



Version P902CIN : Pied d'appui avec tige de type A en acier inox (avec hexagone) et bille R15

Code	Art.	D	H	I	H1	h	A	E	s	d2	R	d1 _{6g}	Q	g	F1 (kN)
-	P902080.TM12X7001CIN	80	20	54	25.5	16	20	16	6.5	9	15	M12	70	130	13
-	P902080.TM12X9001CIN	80	20	54	25.5	16	20	16	6.5	9	15	M12	90	143	13
-	P902080.TM12X11001CIN	80	20	54	25.5	16	20	16	6.5	9	15	M12	110	156	13
-	P902080.TM14X7001CIN	80	20	54	25.5	16	20	16	6.5	9	15	M14	70	145	13
-	P902080.TM14X11001CIN	80	20	54	25.5	16	20	16	6.5	9	15	M14	110	163	13
-	P902080.TM14X13001CIN	80	20	54	25.5	16	20	16	6.5	9	15	M14	130	181	13
-	P902080.TM16X5001CIN	80	20	54	25.5	16	20	16	6.5	9	15	M16	50	139	13
-	P902080.TM16X7001CIN	80	20	54	25.5	16	20	16	6.5	9	15	M16	70	166	13
-	P902080.TM16X9001CIN	80	20	54	25.5	16	20	16	6.5	9	15	M16	90	193	13
-	P902080.TM16X11001CIN	80	20	54	25.5	16	20	16	6.5	9	15	M16	110	220	13
-	P902080.TM16X13001CIN	80	20	54	25.5	16	20	16	6.5	9	15	M16	130	247	13
-	P902080.TM16X15001CIN	80	20	54	25.5	16	20	16	6.5	9	15	M16	150	274	13
-	P902080.TM16X17001CIN	80	20	54	25.5	16	20	16	6.5	9	15	M16	170	301	13
-	P902080.TM16X19001CIN	80	20	54	25.5	16	20	16	6.5	9	15	M16	190	328	13
-	P902105.TM12X7001CIN	105	22	74	28	18.5	21	16	6.5	11	15	M12	70	180	15
-	P902105.TM12X9001CIN	105	22	74	28	18.5	21	16	6.5	11	15	M12	90	193	15
-	P902105.TM12X11001CIN	105	22	74	28	18.5	21	16	6.5	11	15	M12	110	206	15
-	P902105.TM14X7001CIN	105	22	74	28	18.5	21	16	6.5	11	15	M14	70	195	15
-	P902105.TM14X11001CIN	105	22	74	28	18.5	21	16	6.5	11	15	M14	110	231	15
-	P902105.TM14X13001CIN	105	22	74	28	18.5	21	16	6.5	11	15	M14	130	249	15
-	P902105.TM16X5001CIN	105	22	74	28	18.5	21	16	6.5	11	15	M16	50	189	15
-	P902105.TM16X7001CIN	105	22	74	28	18.5	21	16	6.5	11	15	M16	70	216	15
-	P902105.TM16X9001CIN	105	22	74	28	18.5	21	16	6.5	11	15	M16	90	243	15
-	P902105.TM16X11001CIN	105	22	74	28	18.5	21	16	6.5	11	15	M16	110	270	15
-	P902105.TM16X13001CIN	105	22	74	28	18.5	21	16	6.5	11	15	M16	130	297	15
-	P902105.TM16X15001CIN	105	22	74	28	18.5	21	16	6.5	11	15	M16	150	324	15
-	P902105.TM16X17001CIN	105	22	74	28	18.5	21	16	6.5	11	15	M16	170	351	15
-	P902105.TM16X19001CIN	105	22	74	28	18.5	21	16	6.5	11	15	M16	190	378	15
-	P902130.TM12X7001CIN	130	24	99	30	20	21	16	6.5	13	15	M12	70	247	17
-	P902130.TM12X9001CIN	130	24	99	30	20	21	16	6.5	13	15	M12	90	260	17
-	P902130.TM12X11001CIN	130	24	99	30	20	21	16	6.5	13	15	M12	110	273	17
-	P902130.TM14X7001CIN	130	24	99	30	20	21	16	6.5	13	15	M14	70	263	17
-	P902130.TM14X11001CIN	130	24	99	30	20	21	16	6.5	13	15	M14	110	299	17
-	P902130.TM14X13001CIN	130	24	99	30	20	21	16	6.5	13	15	M14	130	317	17
-	P902130.TM16X5001CIN	130	24	99	30	20	21	16	6.5	13	15	M16	50	256	17
-	P902130.TM16X7001CIN	130	24	99	30	20	21	16	6.5	13	15	M16	70	283	17
-	P902130.TM16X9001CIN	130	24	99	30	20	21	16	6.5	13	15	M16	90	310	17
-	P902130.TM16X11001CIN	130	24	99	30	20	21	16	6.5	13	15	M16	110	337	17
-	P902130.TM16X13001CIN	130	24	99	30	20	21	16	6.5	13	15	M16	130	364	17
-	P902130.TM16X15001CIN	130	24	99	30	20	21	16	6.5	13	15	M16	150	391	17