

P902



PIE DE APOYO CON FIJACIÓN AL SUELO, PERNO ARTICULADO TIPO A DE ACERO Y BOLA R15

Materiales:

Poliamida reforzada. Resistente a aceites y grasas.

Superficie:

Satinada.

Color:

Negro (RAL 9011).

Insertos:

P902:

Perno roscado y articulado (bola R.15) con base hexagonal de acero galvanizado (tolerancia rosca 6g).

P902CIN

Perno roscado y articulado (bola R.15) con base hexagonal de acero inoxidable (AISI 303) (tolerancia rosca 6g).

Fijación al suelo:

El pie se suministra con los orificios de fijación al suelo cerrados. Para abrirlos, rompa la membrana de plástico (véase la figura).

Requerimientos especiales:

- Bajo pedido, y por determinadas cantidades, los insertos se pueden suministrar con la longitud deseada.
- Bajo pedido, y por determinadas cantidades, el pie se puede suministrar de color naranja (RAL 2004).

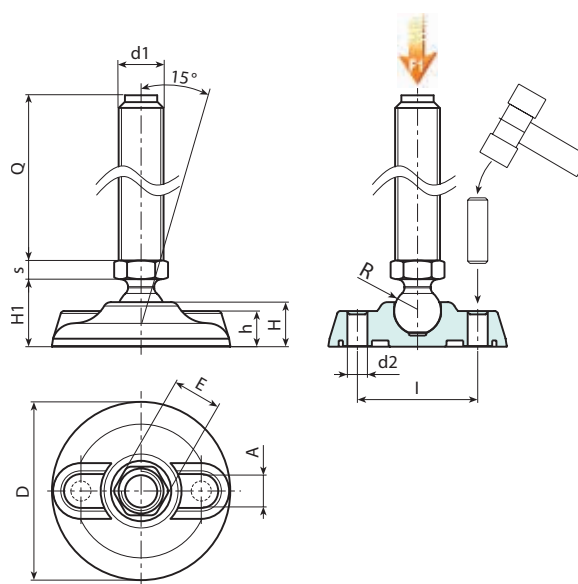

Versión P902: Pie de apoyo con perno tipo A (con hexágono) y bola R15

Código	Art.	D	H	I	H1	h	A	E	s	d2	R	d1 _{6g}	Q	g	F1 (kN)
-	P902080.TM12X5001	80	20	54	25.5	16	20	16	6.5	9	15	M12	50	117	13
-	P902080.TM12X7001	80	20	54	25.5	16	20	16	6.5	9	15	M12	70	130	13
-	P902080.TM12X9001	80	20	54	25.5	16	20	16	6.5	9	15	M12	90	143	13
-	P902080.TM12X11001	80	20	54	25.5	16	20	16	6.5	9	15	M12	110	156	13
-	P902080.TM14X5001	80	20	54	25.5	16	20	16	6.5	9	15	M14	50	126	13
-	P902080.TM14X7001	80	20	54	25.5	16	20	16	6.5	9	15	M14	70	145	13
-	P902080.TM14X9001	80	20	54	25.5	16	20	16	6.5	9	15	M14	90	163	13
-	P902080.TM14X11001	80	20	54	25.5	16	20	16	6.5	9	15	M14	110	181	13
-	P902080.TM14X15001	80	20	54	25.5	16	20	16	6.5	9	15	M14	150	217	13
-	P902080.TM16X5001	80	20	54	25.5	16	20	16	6.5	9	15	M16	50	139	13
-	P902080.TM16X7001	80	20	54	25.5	16	20	16	6.5	9	15	M16	70	166	13
-	P902080.TM16X9001	80	20	54	25.5	16	20	16	6.5	9	15	M16	90	193	13
-	P902080.TM16X11001	80	20	54	25.5	16	20	16	6.5	9	15	M16	110	220	13
-	P902080.TM16X13001	80	20	54	25.5	16	20	16	6.5	9	15	M16	130	247	13
-	P902080.TM16X15001	80	20	54	25.5	16	20	16	6.5	9	15	M16	150	274	13
-	P902080.TM16X17001	80	20	54	25.5	16	20	16	6.5	9	15	M16	170	301	13
-	P902080.TM16X19001	80	20	54	25.5	16	20	16	6.5	9	15	M16	190	328	13
-	P902105.TM12X5001	105	22	74	28	18.5	21	16	6.5	11	15	M12	50	167	15
-	P902105.TM12X7001	105	22	74	28	18.5	21	16	6.5	11	15	M12	70	180	15
-	P902105.TM12X9001	105	22	74	28	18.5	21	16	6.5	11	15	M12	90	193	15
-	P902105.TM12X11001	105	22	74	28	18.5	21	16	6.5	11	15	M12	110	206	15
-	P902105.TM14X5001	105	22	74	28	18.5	21	16	6.5	11	15	M14	50	176	15
-	P902105.TM14X7001	105	22	74	28	18.5	21	16	6.5	11	15	M14	70	195	15
-	P902105.TM14X9001	105	22	74	28	18.5	21	16	6.5	11	15	M14	90	213	15
-	P902105.TM14X11001	105	22	74	28	18.5	21	16	6.5	11	15	M14	110	231	15
-	P902105.TM14X15001	105	22	74	28	18.5	21	16	6.5	11	15	M14	150	268	15
-	P902105.TM16X5001	105	22	74	28	18.5	21	16	6.5	11	15	M16	50	189	15

P902



PIE DE APOYO CON FIJACIÓN AL SUELO, PERNO ARTICULADO TIPO A DE ACERO Y BOLA R15

Código	Art.	D	H	I	H1	h	A	E	s	d2	R	d1 _{6g}	Q	g	F1 (kN)
-	P902105.TM16X7001	105	22	74	28	18.5	21	16	6.5	11	15	M16	70	216	15
-	P902105.TM16X9001	105	22	74	28	18.5	21	16	6.5	11	15	M16	90	243	15
-	P902105.TM16X11001	105	22	74	28	18.5	21	16	6.5	11	15	M16	110	270	15
-	P902105.TM16X13001	105	22	74	28	18.5	21	16	6.5	11	15	M16	130	297	15
-	P902105.TM16X15001	105	22	74	28	18.5	21	16	6.5	11	15	M16	150	324	15
-	P902105.TM16X17001	105	22	74	28	18.5	21	16	6.5	11	15	M16	170	351	15
-	P902105.TM16X19001	105	22	74	28	18.5	21	16	6.5	11	15	M16	190	378	15
-	P902130.TM12X5001	130	24	99	30	20	21	16	6.5	13	15	M12	50	234	17
-	P902130.TM12X7001	130	24	99	30	20	21	16	6.5	13	15	M12	70	247	17
-	P902130.TM12X9001	130	24	99	30	20	21	16	6.5	13	15	M12	90	260	17
-	P902130.TM12X11001	130	24	99	30	20	21	16	6.5	13	15	M12	110	273	17
-	P902130.TM14X5001	130	24	99	30	20	21	16	6.5	13	15	M14	50	244	17
-	P902130.TM14X7001	130	24	99	30	20	21	16	6.5	13	15	M14	70	263	17
-	P902130.TM14X9001	130	24	99	30	20	21	16	6.5	13	15	M14	90	281	17
-	P902130.TM14X11001	130	24	99	30	20	21	16	6.5	13	15	M14	110	299	17
-	P902130.TM14X15001	130	24	99	30	20	21	16	6.5	13	15	M14	150	335	17
-	P902130.TM16X5001	130	24	99	30	20	21	16	6.5	13	15	M16	50	256	17
-	P902130.TM16X7001	130	24	99	30	20	21	16	6.5	13	15	M16	70	283	17
-	P902130.TM16X9001	130	24	99	30	20	21	16	6.5	13	15	M16	90	310	17
-	P902130.TM16X11001	130	24	99	30	20	21	16	6.5	13	15	M16	110	337	17
-	P902130.TM16X13001	130	24	99	30	20	21	16	6.5	13	15	M16	130	364	17
-	P902130.TM16X15001	130	24	99	30	20	21	16	6.5	13	15	M16	150	391	17
-	P902130.TM16X17001	130	24	99	30	20	21	16	6.5	13	15	M16	170	418	17
-	P902130.TM16X19001	130	24	99	30	20	21	16	6.5	13	15	M16	190	445	17

Atención: El límite de carga F1 expresado es inferior a la carga de rotura en un 30 % y se entiende como estático. Longitudes perno bajo pedido, con un mínimo de 100 unidades.



Versión P902CIN: Pie de apoyo con perno tipo A - de acero inoxidable - (con hexágono) y bola R15

Código	Art.	D	H	I	H1	h	A	E	s	d2	R	d1 _{6g}	Q	g	F1 (kN)
-	P902080.TM12X7001CIN	80	20	54	25.5	16	20	16	6.5	9	15	M12	70	130	13
-	P902080.TM12X9001CIN	80	20	54	25.5	16	20	16	6.5	9	15	M12	90	143	13
-	P902080.TM12X11001CIN	80	20	54	25.5	16	20	16	6.5	9	15	M12	110	156	13
-	P902080.TM14X7001CIN	80	20	54	25.5	16	20	16	6.5	9	15	M14	70	145	13
-	P902080.TM14X11001CIN	80	20	54	25.5	16	20	16	6.5	9	15	M14	110	163	13
-	P902080.TM14X13001CIN	80	20	54	25.5	16	20	16	6.5	9	15	M14	130	181	13
-	P902080.TM16X5001CIN	80	20	54	25.5	16	20	16	6.5	9	15	M16	50	139	13
-	P902080.TM16X7001CIN	80	20	54	25.5	16	20	16	6.5	9	15	M16	70	166	13
-	P902080.TM16X9001CIN	80	20	54	25.5	16	20	16	6.5	9	15	M16	90	193	13
-	P902080.TM16X11001CIN	80	20	54	25.5	16	20	16	6.5	9	15	M16	110	220	13
-	P902080.TM16X13001CIN	80	20	54	25.5	16	20	16	6.5	9	15	M16	130	247	13
-	P902080.TM16X15001CIN	80	20	54	25.5	16	20	16	6.5	9	15	M16	150	274	13
-	P902080.TM16X17001CIN	80	20	54	25.5	16	20	16	6.5	9	15	M16	170	301	13
-	P902080.TM16X19001CIN	80	20	54	25.5	16	20	16	6.5	9	15	M16	190	328	13
-	P902105.TM12X7001CIN	105	22	74	28	18.5	21	16	6.5	11	15	M12	70	180	15
-	P902105.TM12X9001CIN	105	22	74	28	18.5	21	16	6.5	11	15	M12	90	193	15
-	P902105.TM12X11001CIN	105	22	74	28	18.5	21	16	6.5	11	15	M12	110	206	15
-	P902105.TM14X7001CIN	105	22	74	28	18.5	21	16	6.5	11	15	M14	70	195	15
-	P902105.TM14X11001CIN	105	22	74	28	18.5	21	16	6.5	11	15	M14	110	231	15
-	P902105.TM14X13001CIN	105	22	74	28	18.5	21	16	6.5	11	15	M14	130	249	15
-	P902105.TM16X5001CIN	105	22	74	28	18.5	21	16	6.5	11	15	M16	50	189	15
-	P902105.TM16X7001CIN	105	22	74	28	18.5	21	16	6.5	11	15	M16	70	216	15
-	P902105.TM16X9001CIN	105	22	74	28	18.5	21	16	6.5	11	15	M16	90	243	15
-	P902105.TM16X11001CIN	105	22	74	28	18.5	21	16	6.5	11	15	M16	110	270	15
-	P902105.TM16X13001CIN	105	22	74	28	18.5	21	16	6.5	11	15	M16	130	297	15
-	P902105.TM16X15001CIN	105	22	74	28	18.5	21	16	6.5	11	15	M16	150	324	15
-	P902105.TM16X17001CIN	105	22	74	28	18.5	21	16	6.5	11	15	M16	170	351	15
-	P902105.TM16X19001CIN	105	22	74	28	18.5	21	16	6.5	11	15	M16	190	378	15
-	P902130.TM12X7001CIN	130	24	99	30	20	21	16	6.5	13	15	M12	70	247	17
-	P902130.TM12X9001CIN	130	24	99	30	20	21	16	6.5	13	15	M12	90	260	17
-	P902130.TM12X11001CIN	130	24	99	30	20	21	16	6.5	13	15	M12	110	273	17
-	P902130.TM14X7001CIN	130	24	99	30	20	21	16	6.5	13	15	M14	70	263	17
-	P902130.TM14X11001CIN	130	24	99	30	20	21	16	6.5	13	15	M14	110	299	17
-	P902130.TM14X13001CIN	130	24	99	30	20	21	16	6.5	13	15	M14	130	317	17
-	P902130.TM16X5001CIN	130	24	99	30	20	21	16	6.5	13	15	M16	50	256	17
-	P902130.TM16X7001CIN	130	24	99	30	20	21	16	6.5	13	15	M16	70	283	17
-	P902130.TM16X9001CIN	130	24	99	30	20	21	16	6.5	13	15	M16	90	310	17
-	P902130.TM16X11001CIN	130	24	99	30	20	21	16	6.5	13	15	M16	110	337	17
-	P902130.TM16X13001CIN	130	24	99	30	20	21	16	6.5	13	15	M16	130	364	17
-	P902130.TM16X15001CIN	130	24	99	30	20	21	16	6.5	13	15	M16	150	391	17