

P900ESD

NEW



PIEDINO DI APPOGGIO PICCOLO - IN MATERIALE ESD - CON STELO SNODATO TIPO A IN ACCIAIO E CON SFERA 12.4

Materiali:

Poliammide rinforzata, con additivi conduttivi (ESD-C)
Resistente ad olii e grassi.

Superficie:

Satinata.

Colore:

Nero (RAL 9011).

Inserti:

P900ESD:

Stelo filettato e snodato (sfera 12,4) con base esagonale in acciaio zincato, (tolleranza filetto 6g).

P900CINESD:

Stelo filettato e snodato (sfera 12,4) con base esagonale in acciaio inox (Aisi 303), (tolleranza filetto 6g).

Richieste speciali:

- Su richiesta e per quantità gli inserti possono essere forniti con lunghezze a richiesta.

Note: Questo articolo è prodotto con materiale additivato ESD-C (Electro Static Discharge - Conductive) secondo la norma EN 100015/1 e IEC 61340-5-1. Il prodotto risulta conduttivo e previene la formazione di scariche elettrostatiche facilitandone il passaggio a terra. Una tampografia in colore giallo (ESD-C) aiuta la sua identificazione. Prodotto adatto per linee di produzione di materiale elettronico e per uso su atmosfere esplosive.

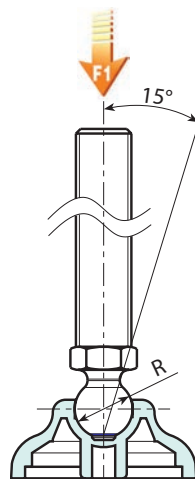
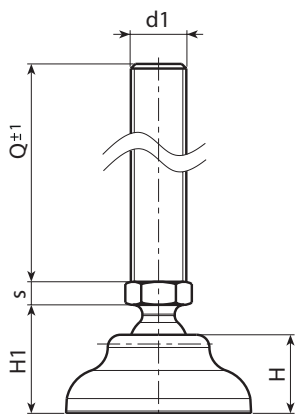
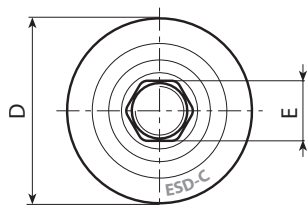

P900ESD

NEW



PIEDINO DI APPOGGIO PICCOLO - IN MATERIALE ESD - CON STELO SNODATO TIPO A IN ACCIAIO E CON SFERA 12.4

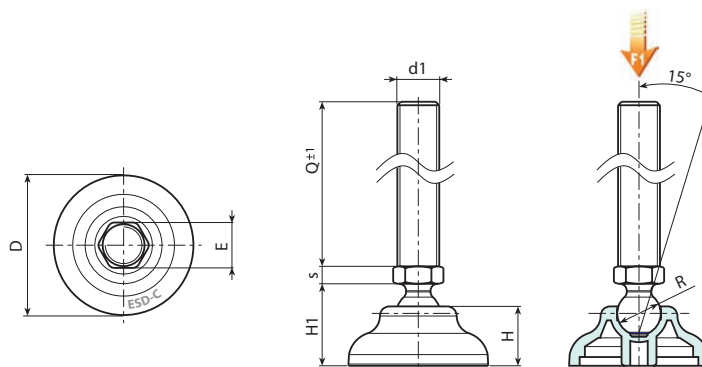

Versione P900ESD: Piede di appoggio con stelo tipo A (con esagono) e sfera 12,4



Codice	Art.	D	H	H1	E	s	R	d1 _{6g}	Q	g	F1 (kN)
-	P90040.TM08X4501ESD	40	17	23	13	5	12.4	M8	45	40	10
-	P90040.TM08X7001ESD	40	17	23	13	5	12.4	M8	70	47	10
-	P90040.TM10X4501ESD	40	17	23	13	5	12.4	M10	45	48	10
-	P90040.TM10X7001ESD	40	17	23	13	5	12.4	M10	70	60	10
-	P90040.TM10X10001ESD	40	17	23	13	5	12.4	M10	100	75	10
-	P90040.TM12X4501ESD	40	17	23	13	5	12.4	M12	45	58	10
-	P90040.TM12X7001ESD	40	17	23	13	5	12.4	M12	70	75	10
-	P90040.TM12X10001ESD	40	17	23	13	5	12.4	M12	100	97	10
-	P90050.TM08X4501ESD	50	18	24	13	5	12.4	M8	45	46	10
-	P90050.TM08X7001ESD	50	18	24	13	5	12.4	M8	70	53	10
-	P90050.TM10X4501ESD	50	18	24	13	5	12.4	M10	45	54	10
-	P90050.TM10X7001ESD	50	18	24	13	5	12.4	M10	70	63	10
-	P90050.TM10X10001ESD	50	18	24	13	5	12.4	M10	100	77	10
-	P90050.TM12X4501ESD	50	18	24	13	5	12.4	M12	45	64	10
-	P90050.TM12X7001ESD	50	18	24	13	5	12.4	M12	70	78	10
-	P90050.TM12X10001ESD	50	18	24	13	5	12.4	M12	100	99	10
-	P90060.TM08X4501ESD	60	20	26	13	5	12.4	M8	45	58	10
-	P90060.TM08X7001ESD	60	20	26	13	5	12.4	M8	70	66	10
-	P90060.TM10X4501ESD	60	20	26	13	5	12.4	M10	45	68	10
-	P90060.TM10X7001ESD	60	20	26	13	5	12.4	M10	70	80	10
-	P90060.TM10X10001ESD	60	20	26	13	5	12.4	M10	100	95	10
-	P90060.TM12X4501ESD	60	20	26	13	5	12.4	M12	45	78	10
-	P90060.TM12X7001ESD	60	20	26	13	5	12.4	M12	70	96	10
-	P90060.TM12X10001ESD	60	20	26	13	5	12.4	M12	100	117	10

Attenzione: Il limite di carico F1 espresso, è inferiore al carico di rottura del 30% e si intende come statico. Lunghezze perno a richiesta con un minimo di 100 pezzi.

Versione P900CINESD: Piede di appoggio con stelo tipo A (con esagono) e sfera 12,4 - in acciaio INOX

INOX



Codice	Art.	D	H	H1	E	s	R	d1 _{6g}	Q	g	F1 (kN)
-	P90040.TM08X4501CINESD	40	17	23	13	5	12.4	M8	45	40	10
-	P90040.TM08X7001CINESD	40	17	23	13	5	12.4	M8	70	47	10
-	P90040.TM10X4501CINESD	40	17	23	13	5	12.4	M10	45	48	10
-	P90040.TM10X7001CINESD	40	17	23	13	5	12.4	M10	70	60	10
-	P90040.TM12X4501CINESD	40	17	23	13	5	12.4	M12	45	58	10
-	P90040.TM12X7001CINESD	40	17	23	13	5	12.4	M12	70	75	10
-	P90040.TM12X10001CINESD	40	17	23	13	5	12.4	M12	100	99	10
-	P90050.TM08X4501CINESD	50	18	24	13	5	12.4	M8	45	46	10
-	P90050.TM08X7001CINESD	50	18	24	13	5	12.4	M8	70	53	10
-	P90050.TM10X4501CINESD	50	18	24	13	5	12.4	M10	45	54	10
-	P90050.TM10X7001CINESD	50	18	24	13	5	12.4	M10	70	63	10
-	P90050.TM12X4501CINESD	50	18	24	13	5	12.4	M12	45	64	10
-	P90050.TM12X7001CINESD	50	18	24	13	5	12.4	M12	70	78	10
-	P90050.TM12X10001CINESD	50	18	24	13	5	12.4	M12	100	102	10
-	P90060.TM08X4501CINESD	60	20	26	13	5	12.4	M8	45	58	10
-	P90060.TM08X7001CINESD	60	20	26	13	5	12.4	M8	70	66	10
-	P90060.TM10X4501CINESD	60	20	26	13	5	12.4	M10	45	68	10
-	P90060.TM10X7001CINESD	60	20	26	13	5	12.4	M10	70	80	10
-	P90060.TM12X4501CINESD	60	20	26	13	5	12.4	M12	45	78	10
-	P90060.TM12X7001CINESD	60	20	26	13	5	12.4	M12	70	96	10
-	P90060.TM12X10001CINESD	60	20	26	13	5	12.4	M12	100	120	10

Attenzione: Il limite di carico F1 espresso, è inferiore al carico di rottura del 30% e si intende come statico. Lunghezze perno a richiesta con un minimo di 100 pezzi.

