

P801



MOUNTING FOOT WITH REVOLVING STEM AND GROUND FIXING

Materials:

Reinforced polyamide.
Resistant to oils and greases.

Surface finish:

Satin.

Colour:

Black (RAL 9011).

Inserts:

Galvanised steel non-articulated revolving threaded stem, fixed with a circlip.

(1) Circlip in black oxide treated steel UNI 7435.

(2) Stainless steel washer (Aisi 304).

Ground fixing:

The mounting foot is supplied with closed holes for anchoring to the ground. To open them pierce the plastic membrane (see drawing).

Special requests:

- Upon request and for special quantities inserts can be supplied with customised lengths.
- Upon request and for special quantities the foot can be supplied in Orange (RAL 2004).

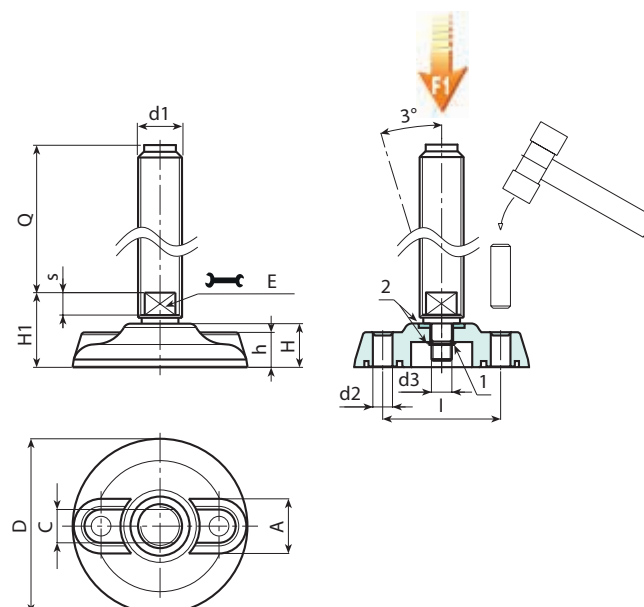

Version P801: Mounting foot with revolving stem and fixed with a circlip.

Code	Art.	D	H	I	H1	h	A	s	d2	d3	E	d1 _{6g}	Q	g	F1 (kN)
-	P801080.TM12X05001	80	20	54	32	16	18,5	8	9	8	10	M12	50	130	13
-	P801080.TM12X09001	80	20	54	32	16	18,5	8	9	8	10	M12	90	143	13
-	P801080.TM14X11001	80	20	54	32	16	18,5	8	9	8	12	M14	110	175	13
-	P801080.TM16X15001	80	20	54	32	16	18,5	8	9	8	13	M16	150	274	13
-	P801105.TM16X15001	105	22	74	36	18	22	8	11	10	13	M16	150	324	15
-	P801105.TM20X15001	105	22	74	36	18	22	10	11	10	17	M20	150	417	15
-	P801105.TM20X19001	105	22	74	36	18	22	10	11	10	17	M20	190	500	15
-	P801105.TM24X15001	105	22	74	36	18	22	10	11	10	19	M24	150	553	15
-	P801105.TM24X19001	105	22	74	36	18	22	10	11	10	19	M24	190	673	15
-	P801105.TM30X15001	105	22	74	36	18	22	10	11	10	24	M30	150	866	15
-	P801105.TM30X19001	105	22	74	36	18	22	10	11	10	24	M30	190	1055	15
-	P801130.TM16X09001	130	24	99	36	20	21	10	13	10	13	M16	90	310	17
-	P801130.TM16X15001	130	24	99	36	20	21	10	13	10	13	M16	150	391	17
-	P801130.TM20X11001	130	24	99	36	20	21	10	13	10	17	M20	110	404	17
-	P801130.TM20X15001	130	24	99	36	20	21	10	13	10	17	M20	150	485	17
-	P801130.TM20X19001	130	24	99	36	20	21	10	13	10	17	M20	190	565	17
-	P801130.TM24X15001	130	24	99	36	20	21	10	13	10	19	M24	150	618	17
-	P801130.TM24X19001	130	24	99	36	20	21	10	13	10	19	M24	190	738	17
-	P801130.TM30X15001	130	24	99	36	20	21	10	13	10	24	M30	150	931	17
-	P801130.TM30X19001	130	24	99	36	20	21	10	13	10	24	M30	190	1120	17