

P315



TRILLINGSDEMPENDE CILINDERSVOET MET ENKELE DRAADEIND

Materiaal:

Natuurlijk rubber (NR).

Hardheid rubber:

Hardheid 55 Shore A (tolerantie $\pm 5\%$).

Oppervlak:

Glad.

Kleur:

Zwart (RAL 9011).

Inzetstuk:

- (1) Draadeind in verzinkt boriumstaal (schroefdraad tolerantie 6g).
(2) Ringetje in lasbaar verzinkt staal.

Speciale verzoeken:

- Op aanvraag en voor grote hoeveelheden (vanaf 100 stuks) kunnen de trillingsdempende voeten worden geleverd met hardheid 45 of 70 Shore A.
- Op aanvraag en voor grote hoeveelheden (vanaf 100 stuks) kunnen de trillingsdempende voeten worden geleverd in verschillende materialen:
 - P316= SBR
 - P317= NBR
 - P318= EPDM

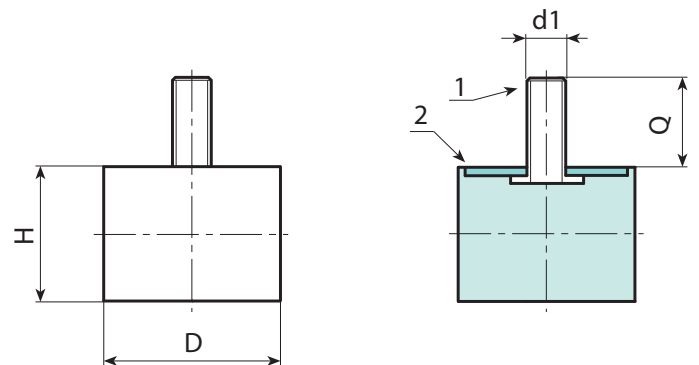

Code	Art.	D	H	d1 _{6g}	Q		Compressiestijfheid (N/mm)
-	P315010.F10M04X1055	10	10	M4	10	2	38
-	P315015.F10M04X1055	15	10	M4	10	4	116.6
-	P315015.F15M04X1055	15	15	M4	10	5	48.3
-	P315015.F20M04X1055	15	20	M4	10	6	38.5
-	P315015.F30M04X1055	15	30	M4	10	7	25.7
-	P315020.F15M06X1555	20	15	M6	15	11	95.9
-	P315020.F20M06X1555	20	20	M6	15	14	57
-	P315020.F30M06X1555	20	30	M6	15	20	39.5
-	P315025.F15M06X1855	25	15	M6	18	17	173
-	P315025.F20M06X1855	25	20	M6	18	20	109
-	P315025.F30M06X1855	25	30	M6	18	24	63.9
-	P315030.F15M08X2055	30	15	M8	20	30	293.3
-	P315030.F20M08X2055	30	20	M8	20	34	160
-	P315030.F30M08X2055	30	30	M8	20	41	87
-	P315040.F20M08X2355	40	20	M8	23	53	354.4
-	P315040.F30M08X2355	40	30	M8	23	68	183.3
-	P315040.F40M10X2855	40	40	M10	28	90	120.5
-	P315050.F20M10X2855	50	20	M10	28	87	623.4
-	P315050.F30M10X2855	50	30	M10	28	106	310.2
-	P315050.F40M10X2855	50	40	M10	28	108	204
-	P315060.F40M10X2855	60	40	M10	28	186	319.6
-	P315070.F40M10X2855	70	40	M10	28	254	503.5
-	P315070.F50M10X2855	70	50	M10	28	294	322.4
-	P315075.F25M12X3755	75	25	M12	37	224	1274.6
-	P315075.F40M12X3755	75	40	M12	37	296	528.3
-	P315075.F50M12X3755	75	50	M12	37	340	378.8
-	P315100.F40M16X4255	100	40	M16	42	584	1167.5
-	P315100.F50M16X4255	100	50	M16	42	666	1489