

P305



TRILLINGSDEMPENDE CILINDERSVOET MET DRAADEIND EN DRAADBUS

Materiaal:

Natuurlijk rubber (NR).

Hardheid rubber:

Hardheid 55 Shore A (tolerantie $\pm 5\%$).

Oppervlak:

Glad.

Kleur:

Zwart (RAL 9011).

Inzetstuk:

- (1) Draadeind in verzinkt boriumstaal (schroefdraad tolerantie 6g).
- (2) Ringetje in lasbaar verzinkt staal.
- (3) Blinde draadbus in verzinkt boriumstaal (schroefdraad tolerantie 6H).

Speciale verzoeken:

- Op aanvraag en voor grote hoeveelheden (vanaf 100 stuks) kunnen de trillingsdempende voeten worden geleverd met hardheid 45 of 70 Shore A.
- Op aanvraag en voor grote hoeveelheden (vanaf 100 stuks) kunnen de trillingsdempende voeten worden geleverd in verschillende materialen:
 - P306= SBR
 - P307= NBR
 - P308= EPDM

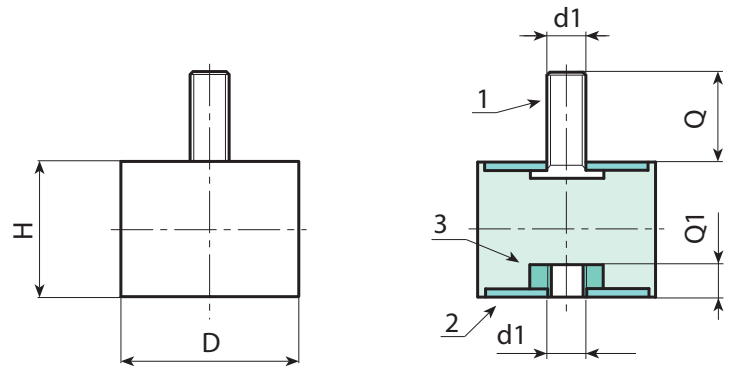

P

Code	Art.	D	H	d1 _{6g/6H}	Q	Q1	g	
-	P305010.F15M04X1055	10	15	M4	10	4	5	46.6
-	P305015.F15M04X1055	15	15	M4	10	4	7	57.1
-	P305015.F20M04X1055	15	20	M4	10	4	7.5	45.1
-	P305020.F20M06X1555	20	20	M6	15	6	18	79.2
-	P305020.F25M06X1555	20	25	M6	15	6	21	36.3
-	P305025.F15M06X1855	25	15	M6	18	6	27	213.8
-	P305025.F20M06X1855	25	20	M6	18	6	26	131.9
-	P305025.F30M06X1855	25	30	M6	18	8	37	67.9
-	P305030.F15M08X2055	30	15	M8	20	8	41	461.7
-	P305030.F20M08X2055	30	20	M8	20	8	47	192.9
-	P305030.F30M08X2055	30	30	M8	20	8	52	101.4
-	P305040.F20M08X2355	40	20	M8	23	8	73	298.3
-	P305040.F30M08X2355	40	30	M8	23	8	86	180.5
-	P305040.F40M10X2855	40	40	M10	28	10	113	126.9
-	P305050.F30M10X2855	50	30	M10	28	10	142	373.2
-	P305050.F40M10X2855	50	40	M10	28	10	156	245.3
-	P305050.F45M10X2855	50	45	M10	28	10	172	180.5
-	P305050.F50M10X2855	50	50	M10	28	10	176	164.4
-	P305060.F30M10X2855	60	30	M10	28	10	195	591.9
-	P305060.F40M10X2855	60	40	M10	28	10	233	350.6
-	P305070.F40M10X2855	70	40	M10	28	10	314	510.2
-	P305075.F25M12X3755	75	25	M12	37	12	296	1177.1
-	P305075.F40M12X3755	75	40	M12	37	12	383	598.5
-	P305075.F55M14X3755	75	55	M14	37	14	482	412.7
-	P305100.F40M16X4255	100	40	M16	42	16	768	1478.5
-	P305100.F55M16X4255	100	55	M16	42	16	865	888.3
-	P305100.F75M16X4255	100	75	M16	42	16	1058	541.5