

P300



LIERIÖMÄINEN TÄRINÄNVAIMENNIN, KIERTEITETTY KAKSOISTAPPI

Materiaalit:

Luonnonkumi (NR).

Kumin kovuus:

Kovuus 55 Shore A (toleranssi $\pm 5\%$).

Pinta:

Sileä.

Väri:

Musta (RAL 9011).

Istukat:

- (1) Kierteitetty vaarnaruuvi, sinkittyä booriterästä (kierretoleranssi 6g).
- (2) Aluslaatta hitsauskelpoista sinkittyä terästä.

Erikoistilaukset:

- Tilauksesta ja 100 kappaleen minimimäärälle tärinänvaimentimet voidaan toimittaa 45- tai 70 Shore A -kovuuksilla.
- Tilauksesta ja 100 kappaleen minimimäärälle tärinänvaimentimet voidaan toimittaa eri materiaalista valmistettuna.
- P301 = SBR
- P302 = NBR
- P303 = EPDM

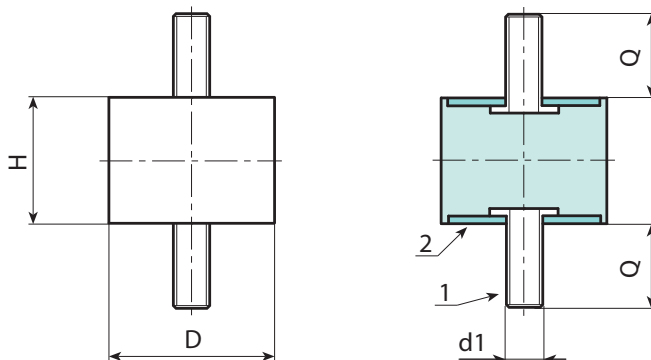

Koodi	Art.	D	H	d1 _{6g}	Q	g	Jäykkyys puristettaessa (N/mm)
-	P300008.F08M03X1055	8	8	M3	10	1.5	37.9
-	P300015.F10M04X1055	15	10	M4	10	5.5	141.7
-	P300015.F15M04X1055	15	15	M4	10	6.5	56.5
-	P300015.F20M04X1055	15	20	M4	10	6.5	44.6
-	P300020.F15M06X1555	20	15	M6	16	18	122.8
-	P300020.F20M06X1555	20	20	M6	16	19	94
-	P300020.F25M06X1555	20	25	M6	16	20	35.9
-	P300025.F15M06X1855	25	15	M6	18	17	211.5
-	P300025.F20M06X1855	25	20	M6	18	27	130.5
-	P300025.F25M06X1855	25	25	M6	18	28	89.8
-	P300025.F30M08X1855	25	30	M8	18	33	67.2
-	P300030.F15M08X2055	30	15	M8	20	44	456.8
-	P300030.F20M08X2055	30	20	M8	20	48	190.8
-	P300030.F30M08X2055	30	30	M8	20	59	100.3
-	P300040.F20M08X2355	40	20	M8	23	54	295.2
-	P300040.F30M08X2355	40	30	M8	23	92	196
-	P300040.F40M10X2855	40	40	M10	28	116	125.6
-	P300050.F20M10X2855	50	20	M10	28	125	930
-	P300050.F30M10X2855	50	30	M10	28	151	369.2
-	P300050.F40M10X2855	50	40	M10	28	171	242.7
-	P300050.F45M10X2855	50	45	M10	28	182	178.6
-	P300050.F50M10X2855	50	50	M10	28	187	160.9
-	P300060.F30M10X2855	60	30	M10	28	214	585.6
-	P300060.F40M10X2855	60	40	M10	28	244	346.9
-	P300070.F40M10X2855	70	40	M10	28	325	504.8
-	P300075.F30M12X3755	75	30	M12	37	354	961.6
-	P300075.F55M14X3755	75	55	M14	37	465	408.3
-	P300100.F40M16X4255	100	40	M16	42	816	1817.2
-	P300100F.55M16X4255	100	55	M16	42	934	878.9
-	P300100F.75M16X4255	100	75	M16	42	1113	530.1