

N248

KNURLED CONTROL KNOB WITH THREADED HOLE INSERT



Materials:

Reinforced polyamide.
Resistant to oils and greases.

Surface finish:

Satin.

Colour:

Black (RAL 9011).

Cap:

Central cap in grey polyamide (RAL 7035).

Inserts:

Galvanised steel insert with threaded through hole (thread tolerance 6H).

Notes:

(*) Side NFLAN flange fixing (optional).

Special requests:

- Upon request and for special quantities inserts can be supplied with custom hole diameter d1.
- Upon request and for special quantities inserts can be supplied in different materials/with different coatings.
- Upon request and for special quantities available in the colours indicated in the chart (attention: reduced range) [page].

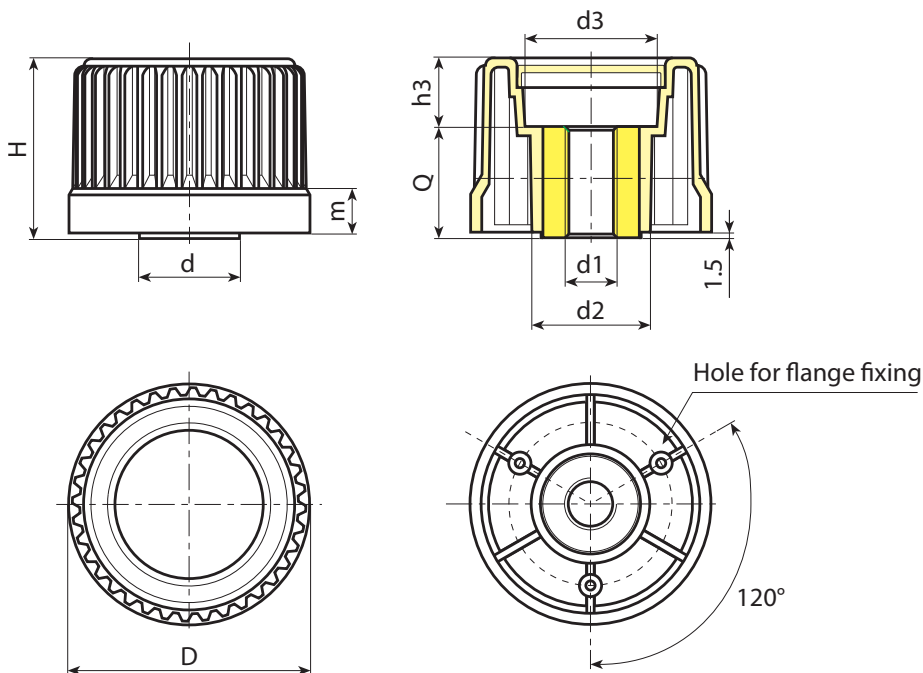

Code	Art.	D	H	m	d	d2	d3	h3	d1 _{6H}	Q	
-	N24830.TM0801 (*)	30	31,5	11,5	20	20	18	5,5	M8	26	79
-	N24843.TM1001	43	37,5	11,5	22	27,5	23	13,5	M10	24	85
-	N24854.TM1201	54	43,5	12	26	32	31	13,5	M12	30	155
-	N24865.TM1201	65	48,5	12	27	32	36	18,5	M12	30	180
-	N24878.TM1401	78	55,5	12,5	31	36	50	23,5	M14	32	270

Threaded holes already provided: N248-30 : M08-M10-M12

Threaded holes already provided: N248-43 : M08-M10-M12

Threaded holes already provided: N248-54 : M08-M10-M12

Threaded holes already provided: N248-65 : M10-M12-M14

Threaded holes already provided: N248-78 : M12-M14-M16

Attention: for a minimum of 100 pieces the diameter d1 can be produced with the requested dimensions.