

M145

EMPUÑADURA DE MANGO GIRATORIO CON ANILLO



Materiales:

Poliamida reforzada.
Resistente a aceites y grasas.

Superficie:

Satinada.

Color:

Negro (RAL 9011).

Insertos:

M145:

Perno roscado giratorio de acero galvanizado, con anillo de alojamiento llave y muelle giratorio de acero armónico (tolerancia rosca 6g).

M145CIN:

Perno roscado giratorio de acero inoxidable (AISI 303), con anillo de alojamiento llave y muelle giratorio de acero inoxidable (AISI 302) (tolerancia rosca 6g).

Requerimientos especiales:

- Bajo pedido, y por determinadas cantidades, colores según la tabla de la [pág.].

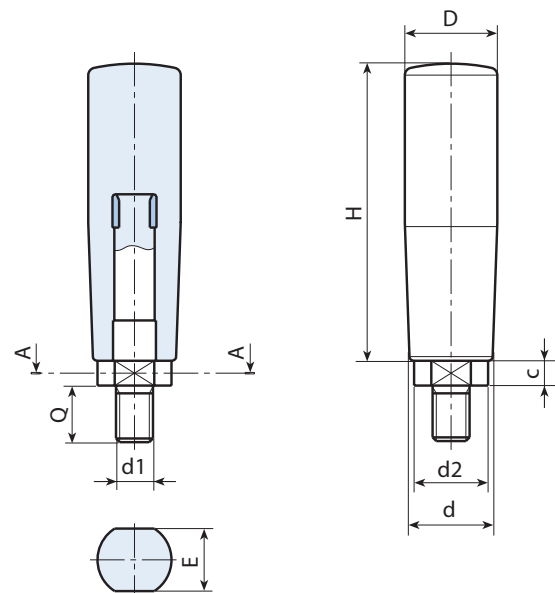

Versión M145: con insertos de acero galvanizado.

Código	art.	H	D	d	d2	c	E	d1 _{6g}	Q	
-	M14550.TM06X1201	50,5	20	15	12	5	10	M6	12	32
-	M14560.TM08X1501	60,5	23,5	18	14	7	13	M8	15	74
-	M14570.TM08X1501	70	25	18,5	14	7	13	M8	15	82
-	M14570.TM10X1501	70	25	18,5	14	7	13	M10	15	86
-	M14580.TM10X1501	79	26	21,5	18	6,5	16	M10	15	92
-	M14580.TM12X1501	79	26	21,5	18	6,5	16	M12	15	96
-	M14590.TM10X1501	89,5	28	23,5	18	6,5	16	M10	15	104
-	M14590.TM12X1501	89,5	28	23,5	18	6,5	16	M12	15	108

Versión M145CIN: con insertos de acero inoxidable (AISI 303).

INOX

Código	art.	H	D	d	d2	c	E	d1 _{6g}	Q	
-	M14550.TM06X1201CIN	50,5	20	15	12	5	10	M6	12	32
-	M14560.TM08X1501CIN	60,5	23,5	18	14	7	13	M8	15	74
-	M14570.TM08X1501CIN	70	25	18,5	14	7	13	M8	15	82
-	M14570.TM10X1501CIN	70	25	18,5	14	7	13	M10	15	86
-	M14580.TM10X1501CIN	79	26	21,5	18	6,5	16	M10	15	92
-	M14580.TM12X1501CIN	79	26	21,5	18	6,5	16	M12	15	96
-	M14590.TM10X1501CIN	89,5	28	23,5	18	6,5	16	M10	15	104
-	M14590.TM12X1501CIN	89,5	28	23,5	18	6,5	16	M12	15	108