

K406



SPOKE HANDWHEEL WITH HANDLE AND INDICATOR SEAT

Materials:

Reinforced and stabilized polyamide. Resistant to oils and greases.

Surface finish:

Satin.

Colour:

Black (RAL 9011).

Main insert:

Galvanised steel insert with smooth through bore (tolerance H10).

Lateral insert:

Brass insert with threaded through hole.
(+) Hexagonal black-oxide treated steel insert with threaded through hole. Fixed with black-oxide treated button head screw ISO 7838.

Hub:

Solid Hub.
(*) Lightweight hub.

Mountable indicator:

Gravity position indicator with 50/80mm diameter (models K650-K660). The indicator can be only used in a vertical position (horizontal machine axis). The indicator must be purchased separately. For further information see article K650 [page 379 380].

Indicator fixing method:

Fasten the indicator with a threaded grub screw M05 inserted in the bore d4, (screw supplied with adapter).

Handwheel fixing method:

The handwheel is fixed to the shaft using a thrust pin (not supplied) to be inserted on the threaded hole d2.

Special Requests:

- Upon request and for a minimum of 50 pieces inserts can be supplied with hole d1 with tolerance H7 and black oxide treated finish. Add letters ZB to the standard code. Example: K406130.T050D0801ZB.
- Upon request and for special quantities inserts can be supplied with custom hole diameter d1.
- Upon request and for special quantities inserts can be supplied in different materials.
- Upon request the handwheels can be supplied with indicator (not assembled for transport).

Combinations Diameters/Indicators:

d5=52.4 --> K650050
d5=87.4 --> K650080 or K660080



K

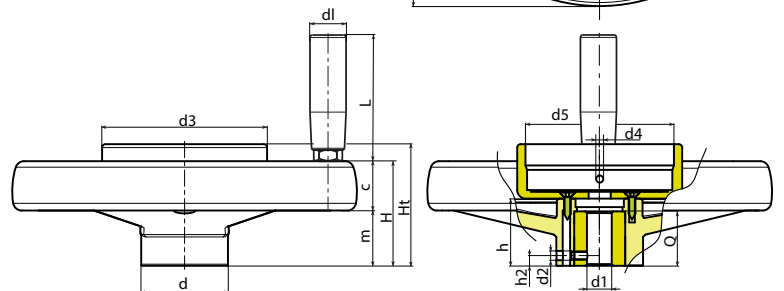
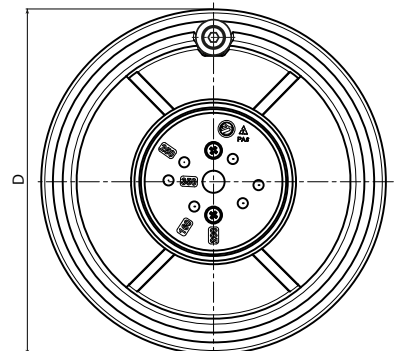

Code	art.	D	d	m	c	H	Ht	h	h2	d2	d3	d4	d5	Dm	d1H10	d1	L	Q	g
-	K406130.T050D0801	129	32	32	18	50	65.5	36	8	M5	62	M5	52,4	18	8	21	65	24	370
-	K406160.T050D0801	159	40	34	23	57	69	40.5	8	M5	62	M5	52,4	22	8	23	76	32	532
-	K406160.T080D0801	159	40	34	23	57	72	40.5	8	M5	97	M5	87,4	22	8	23	76	32	553
-	K406200.T080D0801	198	51	33	28.5	61.5	71	39.5	8	M5	97	M5	87,4	22	8(*)	23	76	32	795
-	K406250.T080D0801	252	55.5	38.5	31.5	70	79	47	8	M5	97	M5	87,4	28	8(*)	25	86	36	1125
-	K406350.T080D0801	346	67.5	43.5	36.5	80	81.5	49.5	8	M5	97	M5	87,4	30	8(*+)	25	86	32	1725

Attention: For a minimum of 50 pieces the diameter d1 can be customised (hole tolerance H10 galvanised and H7 black-oxide treated).
Dm = Maximum obtainable diameter for subsequent machining (widening).