

J260

LEVER TOGGLE LATCH



Materials:

- (1) Technopolymer handle. Resistant to oils and greases.
- (3) Sheared and bent steel lever system.
- (4) Hardened steel U-shaped hook with threaded ends.
- (5) Steel lock nut.
- (6) Steel self-locking nut.
- (7) Sheared and bent catch plate made of hardened steel.
- (8) Hardened steel rotary retainer bush, greased.
- (9) Stainless steel fixing rivets (Aisi 303).

Surface finish:

- (1) Light satin.
- (3-4-5-6-7-8-9) Smooth.

Colour:

- (1) Two-tone (red and black).
- (3-4-5-6-7-8) Standard blue galvanising.
- (9) Natural.

Packaging:

The code includes the toggle latch and its catch plate. The catch plate can also be ordered separately with the following codes:

- J261010.FZ for toggle latch J260010.FZ
- J261014.FZ for toggle latch J260014.FZ
- J261025.FZ for toggle latch J260025.FZ
- J261045.FZ for toggle latch J260045.FZ

Special Requests:

- Upon request and for special quantities the product can be supplied in stainless steel.



Code	Art.	F1 (kN)	R	H	S	Q	W	d	F	A	A1
-	J260010.FZ	1	89	28	16	21÷65	14÷24	3.5	18.5	27	13.5
-	J260014.FZ	14	83	49	11	48÷86	32÷70	3.5	24	38	16
-	J260025.FZ	25	104	70	21	48,5÷95,5	43÷90	5	31	48	21
-	J260045.FZ	45	124	84	28	66÷104	60÷116	7	41	64	28

J260

LEVER TOGGLE LATCH

+135°
-30°

PA6
+G.F.

UL94
HB

RoHS
COMPLIANT

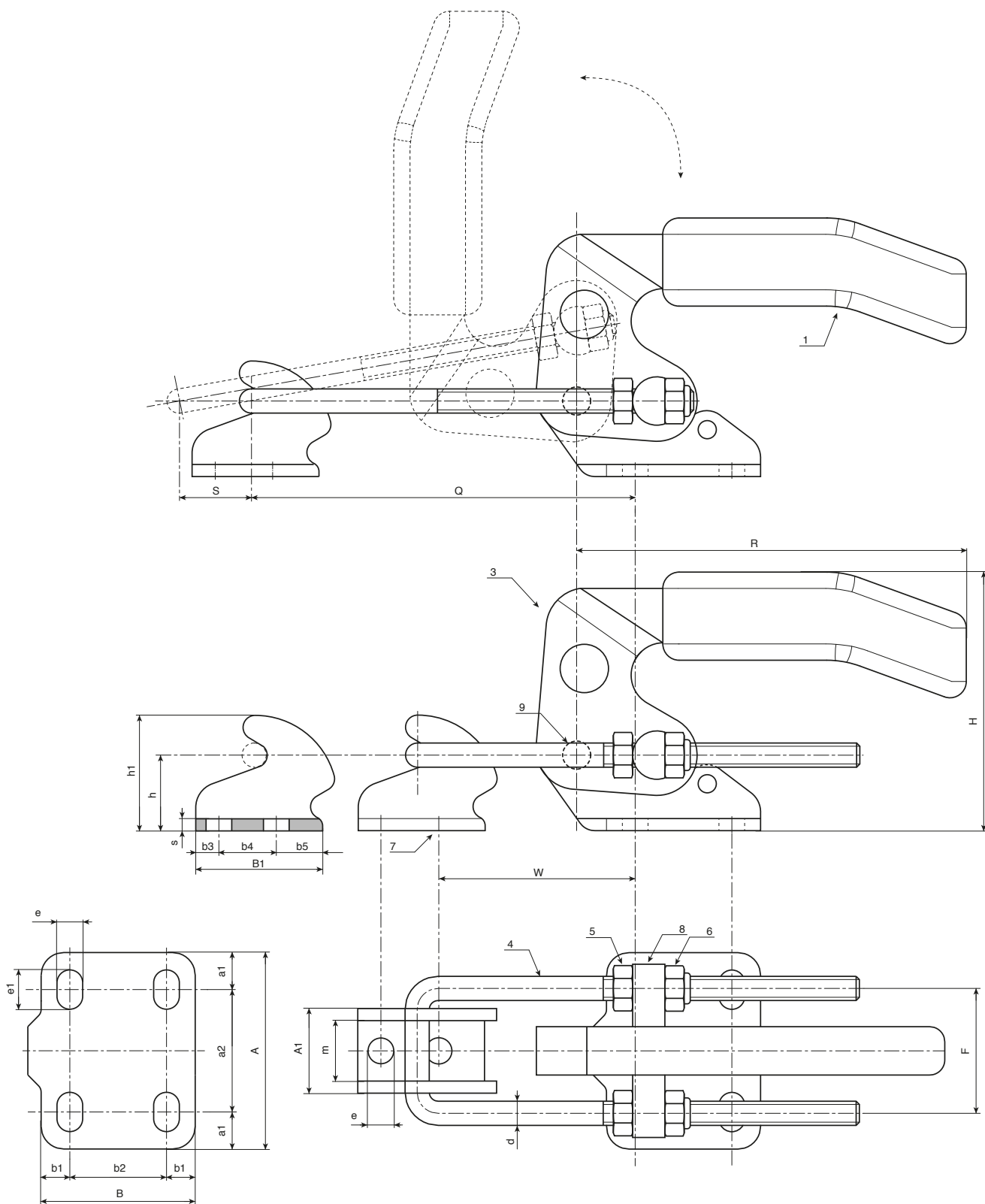

Code	Art.	a1	a2	B	B1	b1	b2	b3	b4	b5	e	e1	h	h1	m	s	
-	J260010.FZ	4.5	18	26	20	5	16	5	10	5	4.5	4.5	12	18	9	2	80
-	J260014.FZ	8	22	26	26	6.25	13.5	7.75	10.5	7.75	5.2	7.5	12	20	11	2.5	150
-	J260025.FZ	10	28	35	32	8	19	6	14	12	6.5	10	19	29	15	3	330
-	J260045.FZ	12	40	51	40	9.5	32	8	19	13	8.5	13	25	39	20	4	750