

UNIVERSAL LOCK FOR TRIANGULAR INSERT KEY

Materials:

- (1) Die-cast zamak lock body M19 (stator) and rotor. 6 mm triangular insert key.
- (2) Elastic washer d. 24x1 with bore d. 19.4.
- (3) Steel hexagon lock nut M19x1.
- (4) Steel locking lever (Qn design N flat - Qe design E bent outwards).
- (5) Conical steel elastic washer d. 12x1.5.
- (6) Steel Phillips dome head screw M5x8.

Surface finish:

- (1) Nickel-plated.
- (2-5) Black oxide treated.
- (3-4-6) Standard blue galvanising.

Key (optional):

- (7) Red plastic key, Art. J09050.TT0816
- ATTENTION: The key is not supplied. To be ordered separately.

Rotation:

90°.

Special Requests:

- None.

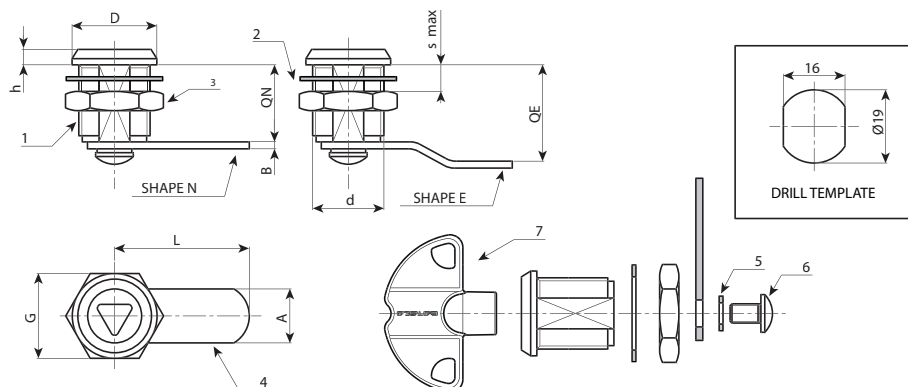

New product version: with 6.5 mm triangle

Code	Art.	A	d	D	L	Q	E	F	G	Ht	H	S(max.)	s1	g	Key
-	J14019.Z06E00X38L	6,5	M19	22	38	20	0	16	22	31	4	6	2.5	50	J090050.TT0616
-	J14019.Z06E02X38L	6,5	M19	22	38	20	2	16	22	31	4	6	2.5	50	J090050.TT0616
-	J14019.Z06E05X35L	6,5	M19	22	35	20	5	16	22	31	4	6	2.5	50	J090050.TT0616
-	J14019.Z06E09X35L	6,5	M19	22	35	20	9	16	22	31	4	6	2.5	50	J090050.TT0616

New product version: with 8 mm triangle

Code	Art.	A	d	D	L	Q	E	F	G	Ht	H	S(max.)	s1	g	Key
-	J14019.Z08E00X38L	8	M19	22	38	20	0	16	22	31	4	6	2.5	50	J090050.TT0816
-	J14019.Z08E02X38L	8	M19	22	38	20	2	16	22	31	4	6	2.5	50	J090050.TT0816
-	J14019.Z08E05X35L	8	M19	22	35	20	5	16	22	31	4	6	2.5	50	J090050.TT0816
-	J14019.Z08E09X35L	8	M19	22	35	20	9	16	22	31	4	6	2.5	50	J090050.TT0816