

H766



KNURLED HOLLOW HANDWHEEL WITH THREADED STUD

Materials:

Reinforced polyamide.
Resistant to oils and greases.

Surface finish:

Satin.

Colour:

Black (RAL 9011).

Inserts:

Galvanised steel threaded stud (thread tolerance 6g).

Special Requests:

- Upon request and for special quantities inserts can be supplied with customised lengths.
- Upon request and for special quantities inserts can be supplied in different materials.
- Upon request and for special quantities available in the colours indicated in the chart [page].

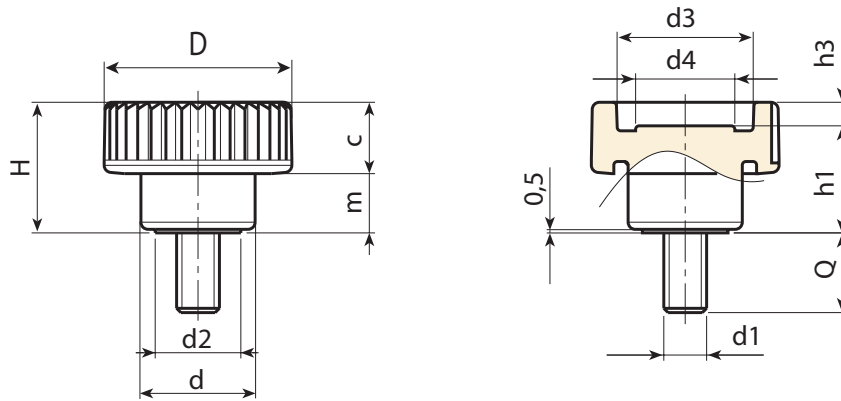

Code	art.	D	H	d	m	c	d2	d3	d4	h1	h3	LM	d1 _{6g}	Q	g
-	H18015.BM0501	15	10.5	10	4.5	6	8	10	7.5	8.5	2	40	M4	11	2,5
-	H18015.BM0501	15	10.5	10	4.5	6	8	10	7.5	8.5	2	40	M4	15	3
-	H18015.BM0501	15	10.5	10	4.5	6	8	10	7.5	8.5	2	40	M4	19	3,5
-	H18015.BM0501	15	10.5	10	4.5	6	8	10	7.5	8.5	2	40	M5	11	4
-	H18015.BM0501	15	10.5	10	4.5	6	8	10	7.5	8.5	2	40	M5	15	4,5
-	H18015.BM0501	15	10.5	10	4.5	6	8	10	7.5	8.5	2	40	M5	19	5
-	H18015.BM0501	21	15	13	6.5	8.5	9.5	15	10.5	12.5	2.5	40	M5	10	6,5
-	H18015.BM0501	21	15	13	6.5	8.5	9.5	15	10.5	12.5	2.5	40	M5	16	6,5
-	H18015.BM0501	21	15	13	6.5	8.5	9.5	15	10.5	12.5	2.5	40	M5	20	7,5
-	H18015.BM0501	21	15	13	6.5	8.5	9.5	15	10.5	12.5	2.5	40	M5	30	9,5
-	H18015.BM0501	21	15	13	6.5	8.5	9.5	15	10.5	12.5	2.5	40	M6	10	7,5
-	H18015.BM0501	21	15	13	6.5	8.5	9.5	15	10.5	12.5	2.5	40	M6	16	8,5
-	H18015.BM0501	21	15	13	6.5	8.5	9.5	15	10.5	12.5	2.5	40	M6	20	9
-	H18015.BM0501	21	15	13	6.5	8.5	9.5	15	10.5	12.5	2.5	40	M6	25	10,5
-	H18015.BM0501	26	18	16	8.5	9.5	12	19	13	15	3	80	M6	10	10
-	H18015.BM0501	26	18	16	8.5	9.5	12	19	13	15	3	80	M6	16	11
-	H18015.BM0501	26	18	16	8.5	9.5	12	19	13	15	3	80	M6	20	11,5
-	H18015.BM0501	26	18	16	8.5	9.5	12	19	13	15	3	80	M6	25	12,5
-	H18015.BM0501	26	18	16	8.5	9.5	12	19	13	15	3	80	M8	16	15,5
-	H18015.BM0501	26	18	16	8.5	9.5	12	19	13	15	3	80	M8	20	16,5
-	H18015.BM0501	26	18	16	8.5	9.5	12	19	13	15	3	80	M8	25	18,5
-	H18015.BM0501	32	23	20	10.5	12.5	15	23	16	18	5	80	M8	16	21
-	H18015.BM0501	32	23	20	10.5	12.5	15	23	16	18	5	80	M8	20	24
-	H18015.BM0501	32	23	20	10.5	12.5	15	23	16	18	5	80	M8	30	30
-	H18015.BM0501	32	23	20	10.5	12.5	15	23	16	18	5	80	M10	20	30
-	H18015.BM0501	32	23	20	10.5	12.5	15	23	16	18	5	80	M10	30	30,5
-	H18015.BM0501	32	23	20	10.5	12.5	15	23	16	18	5	80	M10	40	35,5
-	H18015.BM0501	40	28	25	12.5	15.5	18	28	21	22	6	100	M8	16	29,5
-	H18015.BM0501	40	28	25	12.5	15.5	18	28	21	22	6	100	M8	30	38
-	H18015.BM0501	40	28	25	12.5	15.5	18	28	21	22	6	100	M8	40	44
-	H18015.BM0501	40	28	25	12.5	15.5	18	28	21	22	6	100	M10	30	46
-	H18015.BM0501	40	28	25	12.5	15.5	18	28	21	22	6	100	M12	50	78

LM = maximum mouldable length.