

F175CAT



PA6
+G.F.

UL94
HB



6-LOBE SOLID HANDWHEEL WITH RETAINING CHAIN AND FEMALE THREADED INSERT

Materials:

Reinforced polyamide.
Resistant to oils and greases.

Surface finish:

Satin.

Colour:

Black (RAL 9011).

Inserts:

Brass insert with female threaded hole (thread tolerance 6H).

Chain:

Black acetal (POM) chain. Harmonic stainless steel (Aisi 302) joints, retaining ring and hub hook.

Special Requests:

- Upon request and for special quantities inserts can be supplied in different materials.
- Upon request the chain can be supplied with customised lengths.
- Upon request and for special quantities available in the colours indicated in the chart (attention: reduced range) [page].

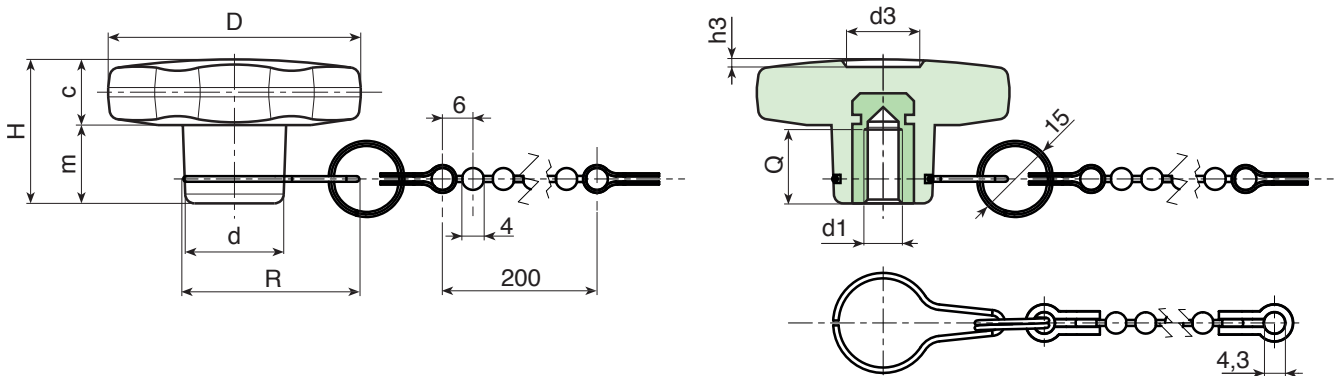

Code	Art.	D	H	d	R	c	m	d3	h3	d1 _{6H}	Q	g
-	F17530.TM0401CAT	30	22	15	32	11	11	9	1.5	M4	15	14.5
-	F17530.TM0501CAT	30	22	15	32	11	11	9	1.5	M5	14	14.5
-	F17530.TM0601CAT	30	22	15	32	11	11	9	1.5	M6	10	15
-	F17540.TM0501CAT	40	24.5	17	33	12	12.5	12	1	M5	14	25
-	F17540.TM0601CAT	40	24.5	17	33	12	12.5	12	1	M6	18	25
-	F17540.TM0801CAT	40	24.5	17	33	12	12.5	12	1	M8	14	24.5
-	F17550.TM0601CAT	50	29	20	35	15.5	13.5	14.5	1.5	M6	16	39
-	F17550.TM0801CAT	50	29	20	35	15.5	14	14.5	1.5	M8	14	39
-	F17550.TM1001CAT	50	29	20	35	15.5	13.5	14.5	1.5	M10	20	40
-	F17560.TM0801CAT	60	34	24	38	16	18	18	1.5	M8	19	62
-	F17560.TM1001CAT	60	34	24	38	16	18	18	1.5	M10	21	62
-	F17560.TM1201CAT	60	34	24	38	16	18	18	1.5	M12	18	65