

F175BF

NEW



6-LOBE SOLID KNOB MADE FROM ANTIBACTERIAL MATERIAL AND STAINLESS STEEL THREADED INSERT

Materials:

Special technopolymer reinforced with high-strength glass fibre, with inorganic silver ion additives which make the material antibacterial (ISO 22196:2011).

Resistant to oils and greases.

Surface finish:

Satin.

Colour:

Black (RAL 9011).

Inserts:

Stainless steel insert with female threaded hole (Aisi 303) (thread tolerance 6H).

Special Requests:

- None.

Notes:

The addition of a special antibacterial additive, based on inorganic silver ions, make these products naturally resistant to microbes, bacteria and fungi by preventing their formation and diffusion. The ions are released slowly, ensuring resistance over a long period even if subjected to frequent washing and sanitising. These ions remain intact at well over 200°C, and therefore suitable for resisting sterilization which normally occurs around 130°C. The material has been certified by credited laboratories and a declaration of conformity will be issued for every item delivered.

The proposed formulation complies with ISO 22196:2011 standard and in particular relates to the following strains:

- Escherichia Coli ATCC 25922
- Candida Albicans ATCC 10231
- Pseudomonas aeruginosa ATCC 13388
- Pseudomonas aeruginosa ATCC 15442
- Klebsiella pneumoniae ATCC 4352
- Staphylococcus aureus ATCC 6538

For all the tests the comparative reduction percentage ranges between 99.5% and 99.9%.

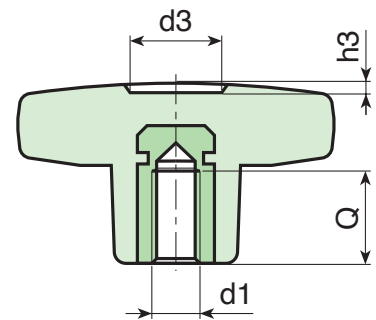
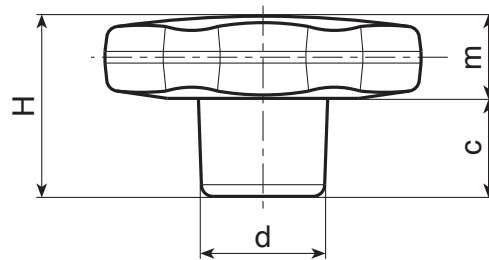
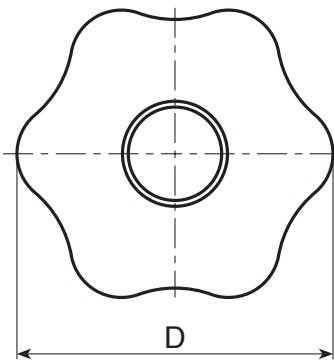

Code	Art.	D	H	d	c	m	d3	h3	d1 _{6H}	Q	g
-	F17530.TM0501BF	30	22	15	11	11	9	1.5	M5	14	11.5
-	F17530.TM0601BF	30	22	15	11	11	9	1.5	M6	10	12
-	F17540.TM0601BF	40	24.5	17	12	12.5	12	1	M6	16	22
-	F17540.TM0801BF	40	24.5	17	12	12.5	12	1	M8	14	21.5
-	F17550.TM0801BF	50	29	20	14	15	14.5	1.5	M8	14	36
-	F17550.TM1001BF	50	29	20	14	15	14.5	1.5	M10	14	37
-	F17560.TM1001BF	60	34	24	16	18	18	1.5	M10	21	59
-	F17560.TM1201BF	60	34	24	16	18	18	1.5	M12	18	62