

E520



PA6
+G.F.

UL94
HB



INDEXED CRANK HANDLE WITH SMOOTH BORE INSERT AND REVOLVING HANDLE

Material:

Reinforced polyamide. Resistant to oils and greases.

Surface finish:

Satin.

Colour:

Black (RAL 9011).

Inserts:

Galvanised steel insert with blind smooth bore (bore tolerance H10).

Lateral insert:

Brass insert with threaded through hole.

Spring:

Stainless steel spring (Aisi 302).

Lateral handle:

E520: Revolving handle art. M144 page ().

E511: Revolving handle art. M145 page ().

E516: Revolving handle art. M129 page ().

Fixing screw:

Black oxide treated steel screw with slotted head.

Special requests:

- Upon request and for special quantities inserts can be supplied in different materials.
- Upon request and for special quantities lever body available in the colours indicated in the chart [page].

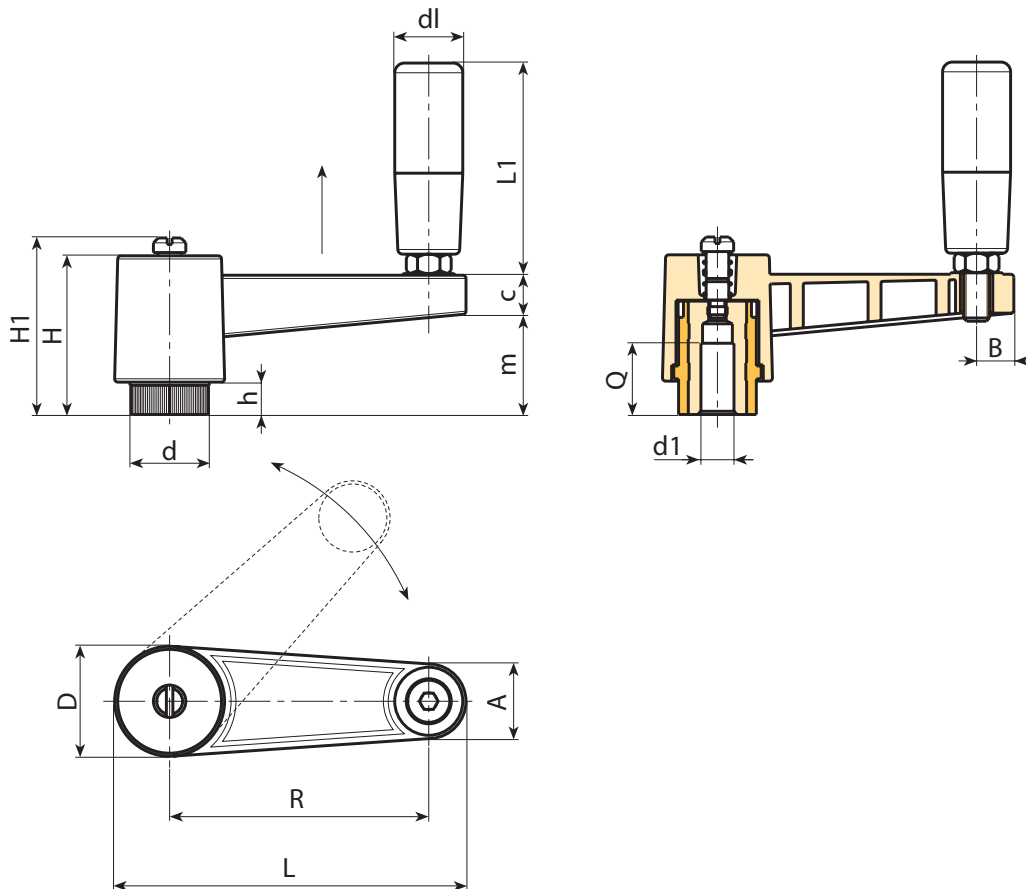

Code	Art.	L	R	H	D	d	m	c	A	B	h	H1	d1 _{H10}	Q	dl	L1	g
-	E520065.TP0501	88,5	65	46	27	19	29	13	17	9	10	-	5	22	19	54	83
-	E520080.TP0501	109	80	50	34	24,5	33	13	22	12	11	54	5	28	21	66	177
-	E520110.TP0501	139	110	50	34	24,5	33	13	22	12	11	54	5	28	21	66	200

E511



INDEXED CRANK HANDLE WITH SMOOTH BORE INSERT AND REVOLVING HANDLE M145

General features:

All unspecified features are identical to basic item E520.

Inserts:

Galvanised steel insert with blind smooth bore (bore tolerance H10).

Lateral handle:

Revolving handle art. M145 page ().



E

Code	Art.	L	R	H	D	d	m	c	A	B	h	H1	d1 _{H10}	Q	dl	L1	g
-	E511065.TP0501	88,5	65	46	27	19	30	13	17	9	10	-	5	22	20	56	92
-	E511080.TP0501	109	80	50	34	24,5	33	13	22	12	11	54	5	28	23,5	68	187
-	E511110.TP0501	139	110	50	34	24,5	33	13	22	12	11	54	5	28	23,5	68	205

E516



INDEXED CRANK HANDLE WITH SMOOTH BORE INSERT AND REVOLVING HANDLE M129

General features:

All unspecified features are identical to basic item E520.

Inserts:

Galvanised steel insert with blind smooth bore (bore tolerance H10).

Lateral handle:

Revolving handle art. M129 page ().



Code	Art.	L	R	H	D	d	m	c	A	B	h	H1	d1 _{H10}	Q	dl	L1	g
-	E516065.TP0501	88,5	65	46	27	19	30	13	17	9	10	-	5	22	20	52	95
-	E516080.TP0501	109	80	50	34	24,5	33	13	22	12	11	54	5	28	23,5	63	197
-	E516110.TP0501	139	110	50	34	24,5	33	13	22	12	11	54	5	28	23,5	63	207