

B324BF

NEW



“EUROMODEL” HANDLE MADE FROM ANTIBACTERIAL MATERIAL WITH THROUGH HOLE AND CAP

Materials:

Special technopolymer reinforced with high-strength glass fibre, with inorganic silver ion additives which make the material antibacterial (ISO 22196:2011).

Resistant to oils and greases.

Surface finish:

Satin.

Colour:

Black (RAL 9011).

Standard cap:

Black polyamide cap (RAL 9001 code 01).

Hole:

Smooth through hole obtained by moulding the plastic.

Special requests:

- None.

Notes:

The addition of a special antibacterial additive, based on inorganic silver ions, make these products naturally resistant to microbes, bacteria and fungi by preventing their formation and diffusion. The ions are released slowly, ensuring resistance over a long period even if subjected to frequent washing and sanitising. These ions remain intact at well over 200°C, and therefore suitable for resisting sterilization which normally occurs around 130°C. The material has been certified by credited laboratories and a declaration of conformity will be issued for every item delivered.

The proposed formulation complies with ISO 22196:2011 standard and in particular relates to the following strains:

- Escherichia Coli ATCC 25922
- Candida Albicans ATCC 10231
- Pseudomonas aeruginosa ATCC 13388
- Pseudomonas aeruginosa ATCC 15442
- Klebsiella pneumoniae ATCC 4352
- Staphylococcus aureus ATCC 6538

For all the tests the comparative reduction percentage ranges between 99.5% and 99.9%.



02

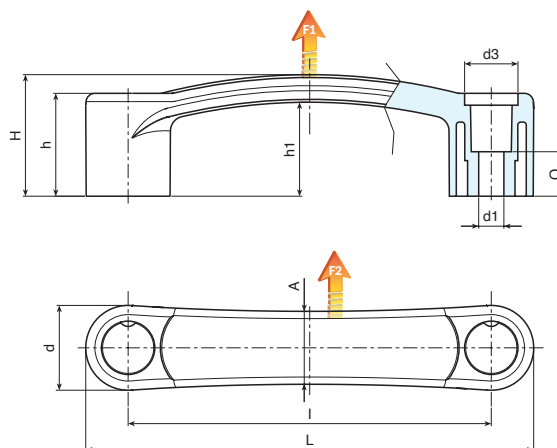

Code	art.	L	l	H	h	h1	A	d	d3	Q	d1	g	F1 (N)	F2 (N)
B324094.0007	B324094.TG06.501BF	118	94	37	33	30	21	24	16	14	6.5	37	2500	2000
B324117.0009	B324117.TG06.501BF	145	117	40.5	34	31.5	24	28	18	15	6.5	58	3700	3500
B324117.0020	B324117.TG08.501BF	145	117	40.5	34	31.5	24	28	18	15	8.5	57	3700	3500
B324132.0006	B324132.TG08.501BF	160	132	43	36.5	34	24	28	18	15	8.5	91	3200	3200

