

B224BF

NEW



FIXED HANDLE WITH THROUGH HOLE MADE FROM ANTIBACTERIAL MATERIAL

Materials:

Special technopolymer reinforced with high-strength glass fibre, with inorganic silver ion additives which make the material antibacterial (ISO 22196:2011). Resistant to oils and greases.

Surface finish:

Satin.

Colour:

Black: (RAL 9011 code 01).

Hole:

Smooth through hole obtained by moulding the plastic.

Special requests:

- None.

Notes:

The addition of a special antibacterial additive, based on inorganic silver ions, make these products naturally resistant to microbes, bacteria and fungi by preventing their formation and diffusion. The ions are released slowly, ensuring resistance over a long period even if subjected to frequent washing and sanitising. These ions remain intact at well over 200°C, and therefore suitable for resisting sterilization which normally occurs around 130°C. The material has been certified by credited laboratories and a declaration of conformity will be issued for every item delivered.

The proposed formulation complies with ISO 22196:2011 standard and in particular relates to the following strains:

- Escherichia Coli ATCC 25922
- Candida Albicans ATCC 10231
- Pseudomonas aeruginosa ATCC 13388
- Pseudomonas aeruginosa ATCC 15442
- Klebsiella pneumoniae ATCC 4352
- Staphylococcus aureus ATCC 6538

For all the tests the comparative reduction percentage ranges between 99.5% and 99.9%.

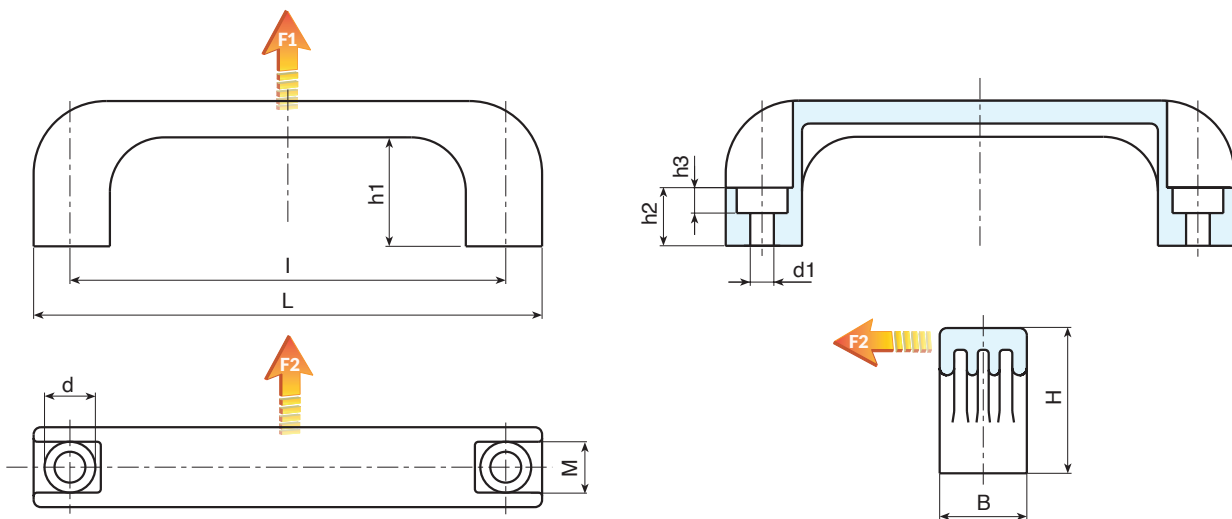

Code	art.	L	I	B	M	H	h1	h2	h3	d	d1	g	F1 (N)	F2 (N)
B224117.0002	B224117.TG6.501PBF	140	117	24	13	40	29	15	7	14	6.5	43	4400	3000
B224117.0009	B224117.TG8.501PBF	140	117	24	13	40	29	15	9	14	8.5	39	4400	3000
B224180.0002	B224180.TG8.501PBF	200	180	28	17	51	39	21	9	14	8.5	74	4000	3000