

# A595CIN NEW



## FULL STAINLESS STEEL INDEXED CLAMPING LEVER WITH THREADED STUD

INOX

### Materials:

Lever body in precision-cast stainless steel (Aisi 304).

### Surface finish:

Brushed.

### Colour:

Natural.

### Inserts:

Stainless steel insert with threaded stud (Aisi 303) (thread tolerance 6g).

### Fixing screw:

Vite in acciaio inox (Aisi 303) con testa chiusa.

### Spring:

Stainless steel spring (Aisi 302).

### Special requests:

- Upon request and for a minimum of 300 pieces inserts can be supplied with customised lengths.

### Attention:

For lengths exceeding LM, the threaded stud is supplied assembled.



01

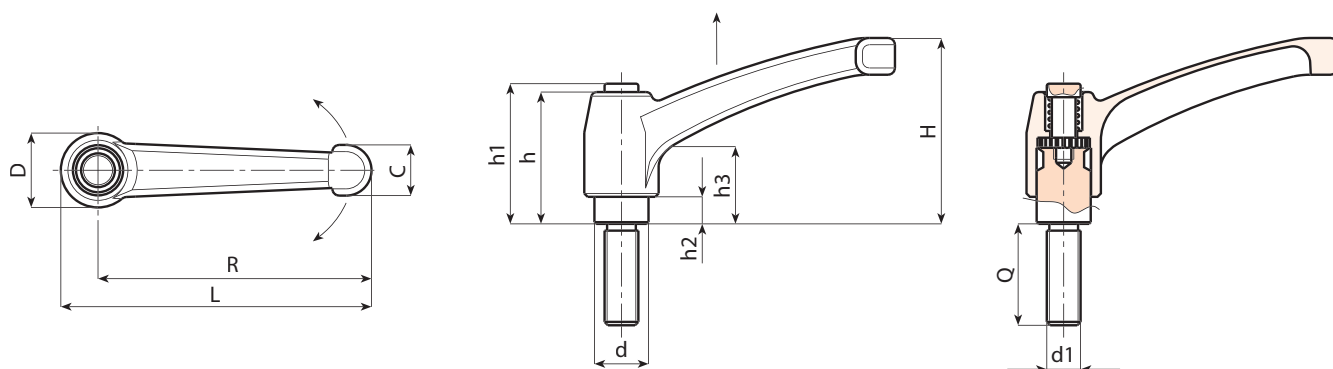

INOX

Code	Art.	L	R	H	D	d	c	h	h1	h2	h3	LM	d16g	Q	
A595043.0001	A595043.IM05X16CIN	50	43	30	14	10	9	26	30	5	14	50	M5	16	31
A595043.0002	A595043.IM05X20CIN	50	43	30	14	10	9	26	30	5	14	50	M5	20	32
A595043.0003	A595043.IM05X30CIN	50	43	30	14	10	9	26	30	5	14	50	M5	30	34
A595043.0004	A595043.IM06X16CIN	50	43	30	14	10	9	26	30	5	14	50	M6	16	31
A595043.0005	A595043.IM06X20CIN	50	43	30	14	10	9	26	30	5	14	50	M6	20	32
A595043.0006	A595043.IM06X30CIN	50	43	30	14	10	9	26	30	5	14	50	M6	30	34
A595065.0001	A595065.IM08X16CIN	75	65	45	19	14	13	32	34	7	14	60	M8	16	82
A595065.0002	A595065.IM08X20CIN	75	65	45	19	14	13	32	34	7	14	60	M8	20	83
A595065.0003	A595065.IM08X30CIN	75	65	45	19	14	13	32	34	7	14	60	M8	30	86
A595065.0004	A595065.IM08X40CIN	75	65	45	19	14	13	32	34	7	14	60	M8	40	89
A595065.0005	A595065.IM10X30CIN	75	65	45	19	14	13	32	34	7	14	60	M10	30	94
A595065.0006	A595065.IM10X40CIN	75	65	45	19	14	13	32	34	7	14	60	M10	40	99
A595080.0001	A595080.IM10X20CIN	91	80	57	22	16	16	40	42	8	16	60	M10	20	146
A595080.0002	A595080.IM10X30CIN	91	80	57	22	16	16	40	42	8	16	60	M10	30	151
A595080.0003	A595080.IM10X40CIN	91	80	57	22	16	16	40	42	8	16	60	M10	40	156
A595080.0004	A595080.IM12X20CIN	91	80	57	22	16	16	40	42	8	16	60	M12	20	150
A595080.0005	A595080.IM12X30CIN	91	80	57	22	16	16	40	42	8	16	60	M12	30	157
A595080.0006	A595080.IM12X50CIN	91	80	57	22	16	16	40	42	8	16	60	M12	50	171
A595094.0001	A595094.IM12X20CIN	107	94	65	26	20	17.5	47	50	10.5	19	60	M12	20	229
A595094.0002	A595094.IM12X30CIN	107	94	65	26	20	17.5	47	50	10.5	19	60	M12	30	236
A595094.0003	A595094.IM14X30CIN	107	94	65	26	20	17.5	47	50	10.5	19	60	M14	30	240
A595094.0004	A595094.IM14X50CIN	107	94	65	26	20	17.5	47	50	10.5	19	60	M14	50	260
A595094.0005	A595094.IM16X50CIN	107	94	65	26	20	17.5	47	50	10.5	19	70	M16	50	278

Customised stud length available for a minimum of 300 pieces.  
LM = maximum turning length.