

A593CIN



INDEXED ZAMAK CLAMPING LEVER WITH THREADED STAINLESS STEEL STUD



Materials:

Lever body in die-cast zamak (zinc, aluminium and copper alloy).

Surface finish:

Smooth. Epoxy powder coating.

Lever body colour:

Glossy black (RAL 9005 cod. 01).
 Matt black (RAL 9005 cod. 20).
 Orange (RAL 2004 code 02).
 Red (RAL 3000 code 16).
 Silver (RAL 9006 cod. 83).
 Grey (RAL 7037 cod. 80).
 Blue (RAL 5015 code 07).
 Untreated lever (code GRE).

Inserts:

Stainless steel insert with threaded stud (Aisi 303) (thread tolerance 6g).

Fixing screw:

Stainless steel screw (Aisi 304) with hexagon socket head.

Spring:

Stainless steel spring (Aisi 302).

Special requests:

- Upon request and for a minimum of 50 pieces inserts can be supplied with customised lengths.

Attention:

For lengths exceeding LM, the threaded stud is supplied assembled.

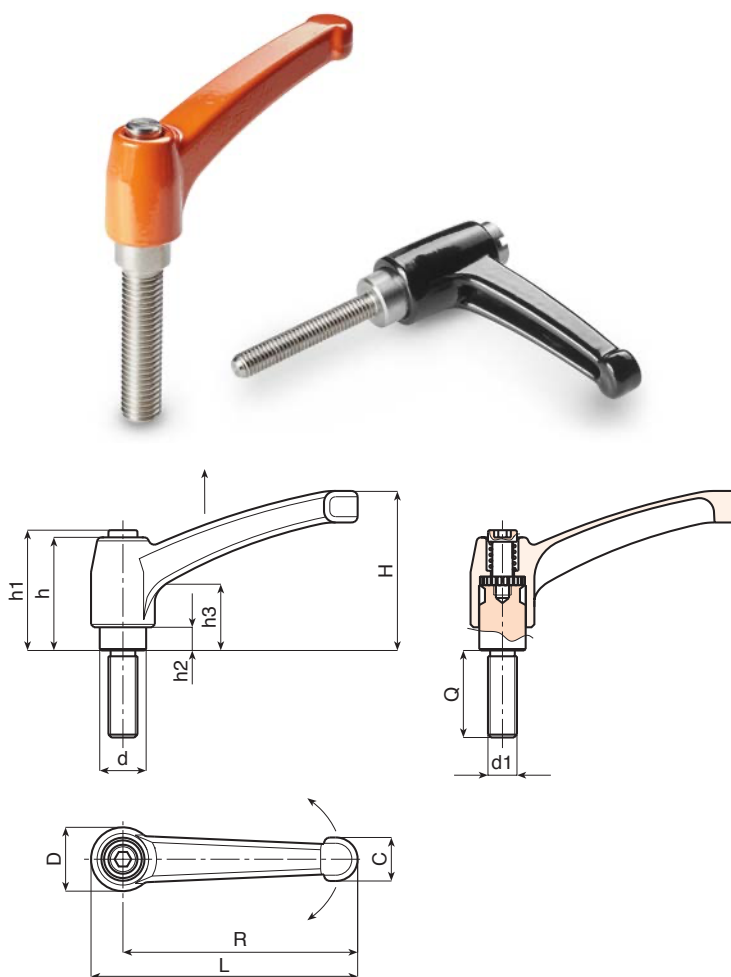

Version 01: Glossy black (Ral 9005)



Code	Art.	L	R	H	D	d	c	h	h1	h2	h3	LM	d1 _{6g}	Q	
A593043.0017	A593043.ZM05X1601CIN	50	43	30	14	10	9	26	30	5	14	50	M5	16	31
A593043.0023	A593043.ZM05X2001CIN	50	43	30	14	10	9	26	30	5	14	50	M5	20	32
A593043.0033	A593043.ZM05X3001CIN	50	43	30	14	10	9	26	30	5	14	50	M5	30	34
A593043.0043	A593043.ZM06X1601CIN	50	43	30	14	10	9	26	30	5	14	50	M6	16	31
A593043.0051	A593043.ZM06X2001CIN	50	43	30	14	10	9	26	30	5	14	50	M6	20	32
A593043.0064	A593043.ZM06X3001CIN	50	43	30	14	10	9	26	30	5	14	50	M6	30	34
A593043.0090	A593043.ZM08X2501CIN	50	43	30	14	10	9	26	30	5	14	60	M8	25	39
A593065.0034	A593065.ZM08X1601CIN	75	65	45	19	14	13	32	34	7	14	60	M8	16	82
A593065.0044	A593065.ZM08X2001CIN	75	65	45	19	14	13	32	34	7	14	60	M8	20	83
A593065.0058	A593065.ZM08X3001CIN	75	65	45	19	14	13	32	34	7	14	60	M8	30	86
A593065.0073	A593065.ZM08X4001CIN	75	65	45	19	14	13	32	34	7	14	60	M8	40	89
A593065.0115	A593065.ZM10X3001CIN	75	65	45	19	14	13	32	34	7	14	60	M10	30	94
A593065.0126	A593065.ZM10X4001CIN	75	65	45	19	14	13	32	34	7	14	60	M10	40	99
A593080.0036	A593080.ZM10X2001CIN	91	80	57	22	16	16	40	42	8	16	60	M10	20	146
A593080.0054	A593080.ZM10X3001CIN	91	80	57	22	16	16	40	42	8	16	60	M10	30	151
A593080.0067	A593080.ZM10X4001CIN	91	80	57	22	16	16	40	42	8	16	60	M10	40	156
A593080.0108	A593080.ZM12X2001CIN	91	80	57	22	16	16	40	42	8	16	60	M12	20	150
A593080.0117	A593080.ZM12X3001CIN	91	80	57	22	16	16	40	42	8	16	60	M12	30	157
A593080.0134	A593080.ZM12X5001CIN	91	80	57	22	16	16	40	42	8	16	60	M12	50	171
A593094.0009	A593094.ZM12X2001CIN	107	94	65	26	20	17.5	47	50	10.5	19	60	M12	20	229
A593094.0016	A593094.ZM12X3001CIN	107	94	65	26	20	17.5	47	50	10.5	19	60	M12	30	236
A593094.0044	A593094.ZM14X3001CIN	107	94	65	26	20	17.5	47	50	10.5	19	60	M14	30	240
A593094.0053	A593094.ZM14X5001CIN	107	94	65	26	20	17.5	47	50	10.5	19	60	M14	50	260
A593094.0070	A593094.ZM16X5001CIN	107	94	65	26	20	17.5	47	50	10.5	19	70	M16	50	278

Customised stud length available for a minimum of 300 pieces.

LM = maximum turning length.



A593CIN



Version 20: Matt black (Ral 9005)

Code	Art.	L	R	H	D	d	c	h	h1	h2	h3	LM	d16g	Q	
-	A593043.ZM05X1620CIN	50	43	30	14	10	9	26	30	5	14	50	M5	16	31
A593043.0117	A593043.ZM05X2020CIN	50	43	30	14	10	9	26	30	5	14	50	M5	20	32
A593043.0037	A593043.ZM05X3020CIN	50	43	30	14	10	9	26	30	5	14	50	M5	30	34
A593065.0037	A593065.ZM08X1620CIN	75	65	45	19	14	13	32	34	7	14	60	M8	16	82
A593065.0049	A593065.ZM10X2020CIN	75	65	45	19	14	13	32	34	7	14	60	M8	20	83
A593065.0062	A593065.ZM08X3020CIN	75	65	45	19	14	13	32	34	7	14	60	M8	30	86
A593065.0077	A593065.ZM08X4020CIN	75	65	45	19	14	13	32	34	7	14	60	M8	40	89
A593065.0119	A593065.ZM10X3020CIN	75	65	45	19	14	13	32	34	7	14	60	M10	30	94
A593065.0129	A593065.ZM10X4020CIN	75	65	45	19	14	13	32	34	7	14	60	M10	40	99
A593080.0042	A593080.ZM10X2020CIN	91	80	57	22	16	16	40	42	8	16	60	M10	20	146
A593080.0058	A593080.ZM10X3020CIN	91	80	57	22	16	16	40	42	8	16	60	M10	30	151
A593080.0071	A593080.ZM10X4020CIN	91	80	57	22	16	16	40	42	8	16	60	M10	40	156
-	A593080.ZM12X2020CIN	91	80	57	22	16	16	40	42	8	16	60	M12	20	150
-	A593080.ZM12X3020CIN	91	80	57	22	16	16	40	42	8	16	60	M12	30	157
A593080.0139	A593080.ZM12X5020CIN	91	80	57	22	16	16	40	42	8	16	60	M12	50	171
A593094.0082	A593094.ZM12X2020CIN	107	94	65	26	20	17.5	47	50	10.5	19	60	M12	20	229
A593094.0019	A593094.ZM12X3020CIN	107	94	65	26	20	17.5	47	50	10.5	19	60	M12	30	236
-	A593094.ZM14X3020CIN	107	94	65	26	20	17.5	47	50	10.5	19	60	M14	30	240
-	A593094.ZM14X5020CIN	107	94	65	26	20	17.5	47	50	10.5	19	60	M14	50	260
-	A593094.ZM16X5020CIN	107	94	65	26	20	17.5	47	50	10.5	19	70	M16	50	278

Customised stud length available for a minimum of 300 pieces.

LM = maximum turning length.



Version 02: Orange (Ral 9006)

Code	Art.	L	R	H	D	d	c	h	h1	h2	h3	LM	d16g	Q	
-	A593043.ZM05X1602CIN	50	43	30	14	10	9	26	30	5	14	50	M5	16	31
A593043.0027	A593043.ZM05X2002CIN	50	43	30	14	10	9	26	30	5	14	50	M5	20	32
A593043.0036	A593043.ZM05X3002CIN	50	43	30	14	10	9	26	30	5	14	50	M5	30	34
A593065.0173	A593065.ZM08X1602CIN	75	65	45	19	14	13	32	34	7	14	60	M8	16	82
A593065.0047	A593065.ZM08X2002CIN	75	65	45	19	14	13	32	34	7	14	60	M8	20	83
A593065.0060	A593065.ZM08X3002CIN	75	65	45	19	14	13	32	34	7	14	60	M8	30	86
A593065.0075	A593065.ZM08X4002CIN	75	65	45	19	14	13	32	34	7	14	60	M8	40	89
A593065.0117	A593065.ZM10X3002CIN	75	65	45	19	14	13	32	34	7	14	60	M10	30	94
A593080.0038	A593080.ZM10X2002CIN	91	80	57	22	16	16	40	42	8	16	60	M10	20	146
A593080.0056	A593080.ZM10X3002CIN	91	80	57	22	16	16	40	42	8	16	60	M10	30	151
A593080.0069	A593080.ZM10X4002CIN	91	80	57	22	16	16	40	42	8	16	60	M10	40	156
-	A593080.ZM12X2002CIN	91	80	57	22	16	16	40	42	8	16	60	M12	20	150
-	A593080.ZM12X3002CIN	91	80	57	22	16	16	40	42	8	16	60	M12	30	157
A593080.0136	A593080.ZM12X5002CIN	91	80	57	22	16	16	40	42	8	16	60	M12	50	171
A593094.0078	A593094.ZM12X2002CIN	107	94	65	26	20	17.5	47	50	10.5	19	60	M12	20	229
A593094.0085	A593094.ZM12X3002CIN	107	94	65	26	20	17.5	47	50	10.5	19	60	M12	30	236
-	A593094.ZM14X3002CIN	107	94	65	26	20	17.5	47	50	10.5	19	60	M14	30	240
-	A593094.ZM14X5002CIN	107	94	65	26	20	17.5	47	50	10.5	19	60	M14	50	260
-	A593094.ZM16X5002CIN	107	94	65	26	20	17.5	47	50	10.5	19	70	M16	50	278

Customised stud length available for a minimum of 300 pieces.

LM = maximum turning length.



Version 20: Grey (Ral 7037)

Code	Art.	L	R	H	D	d	c	h	h1	h2	h3	LM	d16g	Q	
-	A593043.ZM05X1680CIN	50	43	30	14	10	9	26	30	5	14	50	M5	16	31
A593043.0119	A593043.ZM05X2080CIN	50	43	30	14	10	9	26	30	5	14	50	M5	20	32
-	A593043.ZM05X3080CIN	50	43	30	14	10	9	26	30	5	14	50	M5	30	34
A593065.0038	A593065.ZM08X1680CIN	75	65	45	19	14	13	32	34	7	14	60	M8	16	82
A593065.0185	A593065.ZM08X2080CIN	75	65	45	19	14	13	32	34	7	14	60	M8	20	83
A593065.0064	A593065.ZM08X3080CIN	75	65	45	19	14	13	32	34	7	14	60	M8	30	86
-	A593065.ZM08X4080CIN	75	65	45	19	14	13	32	34	7	14	60	M8	40	89
-	A593065.ZM10X3080CIN	75	65	45	19	14	13	32	34	7	14	60	M10	30	94
-	A593065.ZM10X4080CIN	75	65	45	19	14	13	32	34	7	14	60	M10	40	99
A593080.0184	A593080.ZM10X2080CIN	91	80	57	22	16	16	40	42	8	16	60	M10	20	146
A593080.0061	A593080.ZM10X3080CIN	91	80	57	22	16	16	40	42	8	16	60	M10	30	151
A593080.0074	A593080.ZM10X4080CIN	91	80	57	22	16	16	40	42	8	16	60	M10	40	156
-	A593080.ZM12X2080CIN	91	80	57	22	16	16	40	42	8	16	60	M12	20	150
-	A593080.ZM12X3080CIN	91	80	57	22	16	16	40	42	8	16	60	M12	30	157
-	A593080.ZM12X5080CIN	91	80	57	22	16	16	40	42	8	16	60	M12	50	171
-	A593094.ZM12X2080CIN	107	94	65	26	20	17.5	47	50	10.5	19	60	M12	20	229
-	A593094.ZM12X3080CIN	107	94	65	26	20	17.5	47	50	10.5	19	60	M12	30	236
-	A593094.ZM14X3080CIN	107	94	65	26	20	17.5	47	50	10.5	19	60	M14	30	240
-	A593094.ZM14X5080CIN	107	94	65	26	20	17.5	47	50	10.5	19	60	M14	50	260
-	A593094.ZM16X5080CIN	107	94	65	26	20	17.5	47	50	10.5	19	70	M16	50	278

Customised stud length available for a minimum of 300 pieces.

LM = maximum turning length.