

A528

KLEMMHEBEL MIT INNENGEWINDE



Material:

Polyamid glasfaserverstärkt (PA6+GF).
Öl- und fettbeständig.

Oberfläche:

Matt.

Farbe:

Schwarz (RAL 9011).

Einsatz:

Gewindebuchse aus Messing (Gewindetoleranz 6H).

Weitere Möglichkeiten:

- Kundenspezifische Materialien der Einsätze.
- Individuelle Farben möglich, siehe Farbtabelle [S. 959].

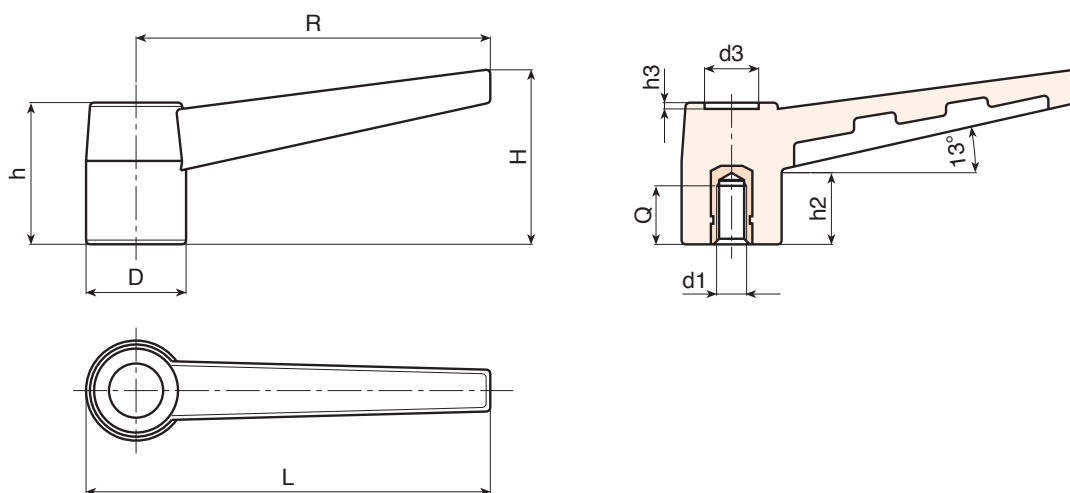

Code	Art.	L	R	H	D	h	h2	h3	d3	d16H	Q	g
A52843.0001	A52843.TM0501	50	43	21.5	15	19	9	1	7	M5	10	8
A52843.0002	A52843.TM0601	50	43	21.5	15	19	9	1	7	M6	10	8
A52868.0001	A52868.TM0601	78	68	36	21	28.5	11	2	10	M6	10	24
A52868.0002	A52868.TM0801	78	68	36	21	28.5	11	2	10	M8	15	22
A52883.0001	A52883.TM0601	93	83	40	24	34	18	2	13	M6	10	30
A52883.0002	A52883.TM0801	93	83	40	24	34	18	2	13	M8	15	32
A52883.0003	A52883.TM1001	93	83	40	24	34	18	2	13	M10	14	32