

A151

“EUROMODEL” FIXED LEVER WITH SMOOTH INSERT



Materials:

Special technopolymer reinforced with high-strength glass fiber.
Resistant to oils and greases.

Surface finish:

Satin.

Colour:

Black (RAL 9011).

Central cap:

Central cap in grey polyamide (RAL 7035).

Inserts:

Galvanised steel insert with smooth through bore (tolerance H10).

Alternative cap colours:

Orange (RAL 2004 code 02).
Blue (RAL 5015 code 07).
Yellow (RAL 1021 code 10).
Red (RAL 3000 code 16).
Green (RAL 6024 code 17).
Black (RAL 9011 code 01).

Special requests:

- Upon request balls and fixing springs (galvanised steel).
- Upon request and for special quantities inserts can be supplied with custom diameter d1.
- Upon request and for special quantities inserts can be supplied in different materials.
- Upon request and for special quantities inserts can be supplied with a different treatment.
- Upon request and for special quantities available in the colours indicated in the chart [page].

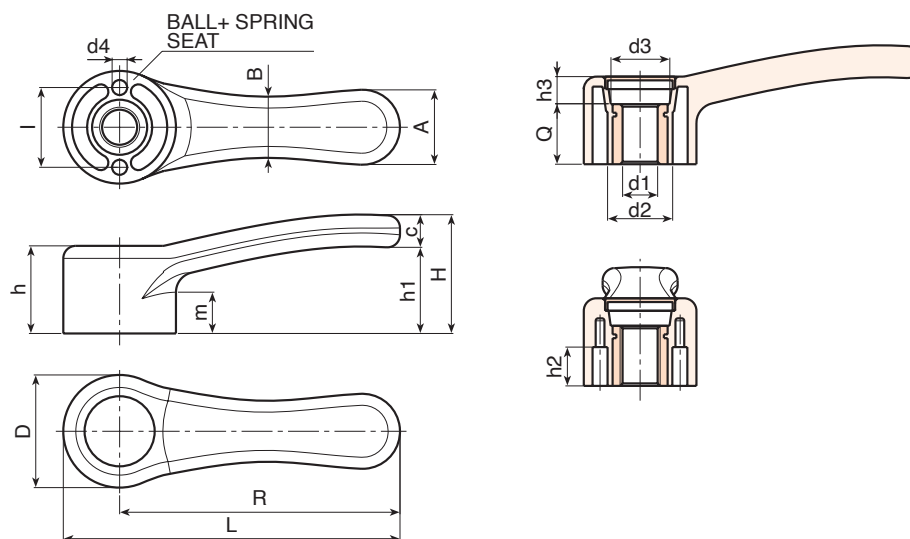

Code	Art.	L	R	D	H	h	h1	h2	h3	m	l	A	B	c	d2	d3	d4	dm	d1H10	Q	g
A151068.0001	A151068.TD0501	84.5	68	33	37	25	27	11.5	9	12	24	20	17	10	20	16	4	10	5	16	45
A151068.0009	A151068.TD1001	84.5	68	33	37	25	27	11.5	9	12	24	20	17	10	20	16	4	10	10	16	44
A151086.0001	A151086.TD0501	104	86	36	40	28	29	14	12	13	26	24	19	11	22	18	5	12	5	16	65
A151086.0003	A151086.TD0801	104	86	36	40	28	29	14	12	13	26	24	19	11	22	18	5	12	8	16	63
A151086.0006	A151086.TD1001	104	86	36	40	28	29	14	12	13	26	24	19	11	22	18	5	12	10	16	61
A151086.0008	A151086.TD1201	104	86	36	40	28	29	14	12	13	26	24	19	11	22	18	5	12	12	16	59
A151112.0001	A151112.TD0501	134.5	112	45	47	36	35	14.5	12	16	32	30	24	13	26	23.5	6	16	5	24	128
A151112.0005	A151112.TD1201	134.5	112	45	47	36	35	14.5	12	16	32	30	24	13	26	23.5	6	16	12	24	124
A151112.0005	A151142.TD0501	169.5	142	55	52	40	36	18	13	17.5	40	37	30	16	32	28	8	20	5	27	250

Attention: for a minimum of 100 pieces the size d1 can be produced with the requested diameter with H10 tolerance.
Dm = Maximum obtainable diameter for subsequent machining (widening).